

EAT•N

Vickers

Filtration Catalog

Technical Catalog



Fluid Analysis



Fluid Analysis **8**

Particle Counter



Target Pro 2 Particle Counter **11**

Breathers



BR110 Breather **14**
Filters out moisture and particles from incoming air



BR210 Breather **14**
Filters out particles from incoming air



MBR110 and MBR210 Breathers **14**
Filters out moisture and particles, ideal for mobile applications

Return Line Filters



HV3R Series Return Line **18**
Flows to: 280 L/min (75 USgpm)
Pressures to: 50 bar (725 PSI)



HV6R Series Return Line **21**
Flows to: 1100 L/min (300 USgpm)
Pressures to: 25 bar (350 PSI)



HV6RD Series Duplex Return Tank **24**
Flows to: 1700 L/min (450 USgpm)
Pressures to: 25 bar (350 PSI)



HF4RT Series In Tank **27**
Flows to: 568 L/min (150 USgpm)
Pressures to: 7 bar (100 PSI)



OFR 30 Series In Line **30**
Flows to: 114 L/min (30 USgpm)
Pressures to: 27,6 bar (400 PSI)



OFR 60/120 Series In Line **33**
Flows to: 450 L/min (120 USgpm)
Pressures to: 27,6 bar (400 PSI)



DLR DIN Series Return Line **36**
Flows to: 400 L/min (105 USgpm)
Pressures to: 25 bar (350 PSI)



LND Series Pressure **39**
Flows to: 400 L/min (105 USgpm)
Pressures to: 25 bar (360 PSI)

In-tank Filters



OFMT Series In Tank **44**
Flows to: 50 L/min (13 USgpm)
Pressures to: 7 bar (100 PSI)



OFRT Series In Tank **50**
Flows to: 1500 L/min (400 USgpm)
Pressures to: 10 bar (150 PSI)



ORFM Series In Tank **62**
Flows to: 851 L/min (225 USgpm)
Pressures to: 10 bar (145 PSI)



ORF 1300 Series Pressure **68**
Flows to: 1300 L/min (343 USgpm)
Pressures to: 25 bar (360PSI)



DRT DIN In Tank **71**
Flows to: 630 L/min (160 USgpm)
Pressures to: 10 bar (150 PSI)

Suction Strainers



OSS Suction Strainers **76**
Flows to: 380 L/min (100 USgpm)

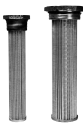

OTM Tank Mounted Strainers **78**
Flows to: 380 L/min (100 USgpm)



F Series Inlet Strainers **80**
Flows to: 380 L/min (100 USgpm)

Spin-on Filters



OFRS 15 Series Spin-on **84**
Flows to: 60 L/min (15 USgpm)
Pressures to: 7 bar (100 PSI)



OFRS 25 Series Spin-on **87**
Flows to: 95 L/min (25 USgpm)
Pressures to: 7 bar (100 PSI)



OFSS30 Series Spin-on **90**
Flows to: 115 L/min (30 USgpm)
Pressures to: 7 bar (100 PSI)



OFRP35 Series Spin-on **93**
 Flows to: 130 L/min (35 USgpm)
 Pressures to: 35 bar (500 PSI)



OFRS 60 Series Spin-on **96**
 Flows to: 225 L/min (60 USgpm)
 Pressures to: 7 bar (100 PSI)



HS22 Series Twin Spin-on **100**
 Flows to: 450 L/min (120 USgpm)
 Pressures to: 14 bar (200 PSI)

Pressure Filters



ECF Series Pressure **104**
 Flows to: 19 L/min (5 USgpm)
 Pressures to: 207 bar (3000 PSI)



LV2P Series Pressure **106**
 Flows to: 110 L/min (29 USgpm)
 Pressures to: 100 bar (1500 PSI)



LV4P Series Pressure **109**
 Flows to: 110 L/min (29 USgpm)
 Pressures to: 100 bar (1500 PSI)



HF2P Series In Line and Subplate **112**
 Flows to: 90 L/min (24 USgpm)
 Pressures to: 210 bar (3000 PSI)



MF2P Series Pressure **115**
 Flows to: 113.5 L/min (30 USgpm)
 Pressures to: 275.5 bar (4000 PSI)



OFPH003/005 Series Pressure **118**
 Flows to: 22 L/min (6 USgpm)
 Pressures to: 310 bar (4500 PSI)



HF4P Series In Line and Subplate **121**
 Flows to: 570 L/min (150 USgpm)
 Pressures to: 345 bar (5000 PSI)



HF3P Series In Line **124**
 Flows to: 570 L/min (150 USgpm)
 Pressures to: 420 bar (6000 PSI)



HF3PS Series Side Mount **127**
 Flows to: 570 L/min (150 USgpm)
 Pressures to: 310 bar (4500 PSI)



DMP DIN Series Pressure **130**
 Flows to: 100 L/min (25 USgpm)
 Pressures to: 100 bar (1500 PSI)



DHP DIN Series Pressure **133**
 Flows to: 400 L/min (106 USgpm)
 Pressures to: 400 bar (5800 PSI)

Off-Line Filters



EPHHF Eaton Portable Handheld Filter **138**
 Flows to: 15 L/min (4 USgpm)
 Pressures to: 3.5 bar (50 PSI)



CCOFRS60 Clean Cart **139**
 Flows to: 38 L/min (10 USgpm)
 Pressures to: 4 bar (65 PSI)



OLF15V Series Off-Line Filter **140**
 Flows to: 19 L/min (5 USgpm)
 Pressures to: 3 bar (45 PSI)

Accessories

Fluid Sampling	141
Differential Indicators	142
Indicator Switch	144
Electrical Pressure Switch	144
Gauge	145
Mounting Flange	145
Welding Bracket	145

Introduction to Eaton Filtration

Fluid Power is one of the most reliable and repeatable forms of power and motion control. When problems are encountered, 80% of the time they are related to inadequate contamination control practices. Eaton has more than a 75-year history of dedication to helping engineers develop, operate and maintain reliable, high quality power and motion control systems.



For a hydraulic or oil lubricated machine, the development of a target cleanliness level and the plan to achieve it is as much a part of system design as the selection of the pump, valves, actuators or bearings.

Vickers Systemic Approach to Contamination Control

- Set a target Cleanliness Level
- Select filters and filter placements to achieve target of contamination control
- Sample fluid and confirm achievement

The systemic contamination cleanliness approach assures the user of the hydraulic system a cost effective approach to contamination control that allows the price of the filters and elements to be quickly recovered by the savings of improved performance, increased component life, increased oil life, increased uptime and fewer repairs.

The goal of systemic contamination control is always the same: to clean the fluid to the point that contamination is not a factor in the failure (catastrophic, intermittent, or degradation) of any component in the system during the desired useful life of that system.

The first step towards this goal is the setting of a target cleanliness level that takes into account the specific needs of the system.

Once the target has been set, the next step is to select and position filters in the system so that the target can be achieved in a cost effective manner.

After the machine is in operation, the last and ongoing step is to confirm that the target cleanliness level is being maintained.

This is most often accomplished by sending a fluid sample to a particle counting laboratory that gives cleanliness code data to established standards. If the target is being met, the system only needs to have filters maintained and the fluid retested periodically. If the cleanliness target is not being achieved, corrective actions need to be taken. Sometimes a change in maintenance practices is needed, but at other times a shift to a finer grade of filter elements or additional filter housings may be needed.

There are four primary sources for solid contamination to enter a hydraulic fluid.

They are: contaminated new oil, built-in contamination, ingressed contamination and internally-generated contamination.

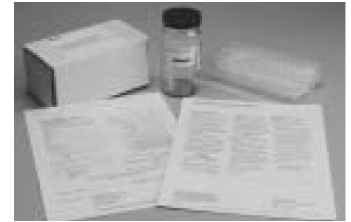

Eaton Fluid Analysis Service PN 894276

Sources of Contamination

Eaton doc. 561, page 8

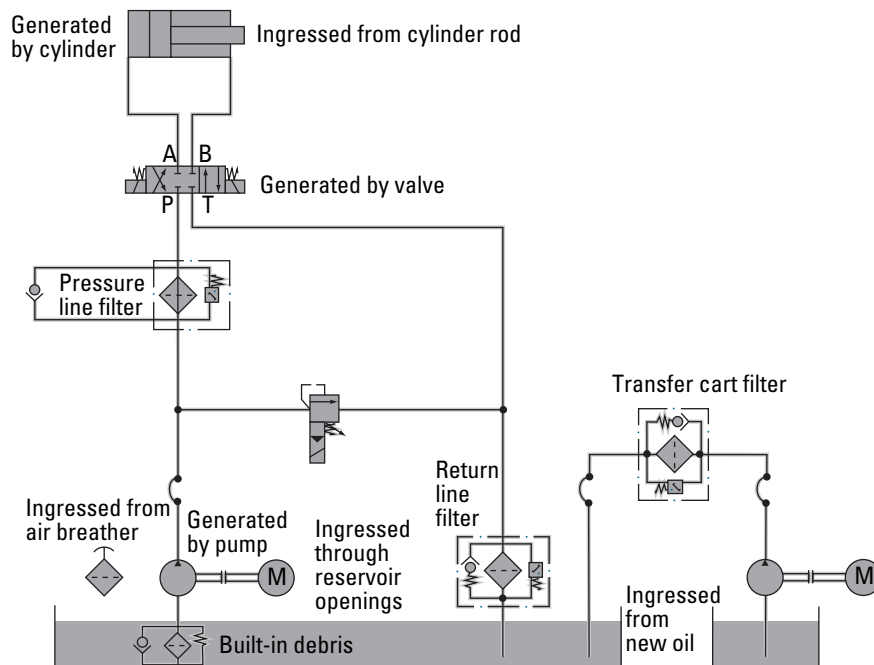

Introduction to Eaton Filtration

Contaminated New Oil

Although hydraulic and lubrication fluids are refined and blended under relatively clean conditions, the fluid travels through many hoses and pipes before it is stored in drums or in a bulk tank at the user's facility. At this point, the fluid is no longer clean as the fluid lines it has traveled through have contributed metal and rubber particles, and the drums have added flakes of metal or scale. Storage tanks are a real problem because water condenses in them causing rust particles. Contamination from the atmosphere can



Eaton Clean Cart

also find its way into the tank unless satisfactory air breathers are fitted.

If the fluid is stored under reasonable conditions, the principal contaminants on delivery to the machine will

be metal, silica and fibers. With fluids from reputable suppliers, sampling has shown typical Cleanliness Levels of 17/16/14 or dirtier. Using a portable transfer cart fitted with a high efficiency filter, contamination should be removed from new fluids before the contamination enters and damages the components in the system.

Built-in Contamination

New machinery always contains a certain amount of built-in contamination. Care in system assembly and in new component flushing reduces this but never eliminates it. Typical built-in



Eaton H2O Gate Reservoir Breather BR110

contaminant's are burrs, chips, flash, dirt, dust, fiber, sand, moisture, pipe sealant, weld splatter, paint and flushing solution.

Ingressed Contamination

Contamination from the immediate surroundings can be ingressed into the fluid power or lubrication system. On large installations, such as those within steelworks or automotive plants, it is relatively easy to know the environmental conditions, though they vary considerably. For example, a coke oven system operates in conditions very different from a similar system in a cold mill. For mobile equipment, there is a very wide variation in environmental conditions by application, location and even by weather conditions (i.e. high winds).

The key is to severely limit the access environmental contamination has to enter the hydraulic or lubrication system. There are four major ways dirt can enter a system: reservoir vent ports (breathers), power unit or system access plates, components left open during maintenance and cylinder seals.

Generated Contamination

The most dangerous contamination to a system is the contamination generated by the system itself. These particles are "work hardened" to a greater hardness than the surface from which they came, and are very aggressive in causing further wear in the system. In a system running on properly cleaned fluid very few particles are generated, although all components (especially pumps) create a small amount of particles during routine operation. In a system where these particles are not quickly captured the elevated contamination levels will cause the number of additional generated particles to increase at a highly accelerated rate! The best way to prevent contamination generation within a system is to start with a clean (fully flushed) system and keep the system fluid clean.

Introduction to Eaton Filtration

Filter Element Initial Efficiency

The international standard for rating the efficiency of a hydraulic or lubrication filter is the Multipass Filter Performance Beta Test (ISO 4572). The results of this test are reported as a ratio of number of particles greater than a designated size upstream of the test filter compared with the number of same size particles downstream of the test filter. These results are then expressed as a Beta ratio.

Multipass testing has greatly aided engineers in the development of better and more efficient filter elements, and it has helped the design engineer who needed to specify a filter element's performance. But, there's little correlation between multipass efficiencies and system cleanliness needs. In the final performance analysis, the goal is properly cleaned fluid and not just very high Beta ratios and dirt capacity. The most important information needed by a designer or user of a hydraulic system is the system cleanliness they can expect when that filter and media are properly installed in the system.

Each grade of Eaton high efficiency filter media construction is thoroughly multipass tested and then rated with the system cleanliness level expected to be achieved with the use of that product. The assumptions behind these cleanliness ratings are: 1) the filter sees full system flow, 2) the filter is the primary filter in the system, and 3) air breathers along with recognized maintenance

practices will limit dirt ingress from the atmosphere.

A major problem in correlating multipass test claims to real world fluid cleanliness levels is that real systems operation greatly stresses the element. In active systems, flow rate changes (often several a minute), pressure pulses (hundreds a minute), decompression shock waves, cold starts, and other variables all work to degrade a filter's performance. In multipass testing the

BETA RATIOS AND CORRESPONDING EFFICIENCIES

Beta Ratios	Efficiency
1	0%
2	50.00%
5	80.00%
10	90.00%
20	95.00%
75	98.00%
100	99.00%
200	99.50%
1000	99.90%
5000	99.98%

Beta ratios and dirt capacity are only a guide to system cleanliness needs
Eaton doc. 561, page 19

element is subject to one gradual rise in differential pressure as the element loads!

Flow fatigue test protocol (ISO 3724) leaves many important questions unanswered. Again the element is tested in laboratory conditions that cannot duplicate the interaction of the many forces working to stress and degrade the element. This laboratory test may fail to answer the question of how an aged element will perform during the latter part of its service life.

Eaton Media Construction

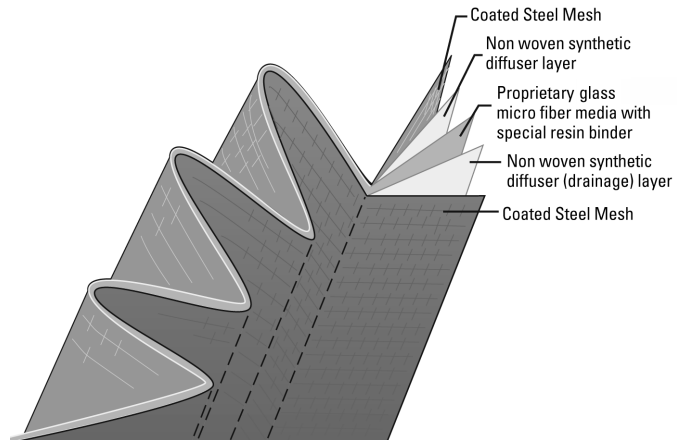

The best way to deal with this issue is to look at the construction and feel the element pleats. Are the pleats well supported? Do they flex under hand pressure? Any element that fails these simple tests will fail to maintain efficiency and integrity, and will not maintain the targeted cleanliness level.

Additionally, look at the pack construction. Steel wire mesh is very important in element construction. Wire keeps the pleats from flexing, and gives the filter medium the support it needs to keep from failing due to fatigue. The downstream wire mesh also serves as a last chance protection in case of unexpectedly severe

stress that causes element media rupture.

Elements without downstream wire mesh are not recommended for use in hydraulic or lubrication systems with even mild stress. This rule is important as the relatively higher cost of wire mesh has lured some filter manufacturers to take the wire mesh out and use cheaper substitutes without dealing with the real world issues of stress and last chance protection.

Filter Condition Indicators

After the filters are placed within the system, the next consideration is how the user is going to know when to change the element. The answer recommended in

LIMITS ON CORRELATION BETWEEN "BETA" AND SYSTEM CLEANLINESS AND "DIRT CAPACITY" AND SERVICE LIFE

	Laboratory Procedure	Real World
Pressure Rise	One gradual rise	Thousands of changes
Fatigue Cycles	One	Millions
Element Aging	Minutes	Months
Element Life	One hour	800+ hours
Contaminant	AC fine test dust	Debris, water, gas
Challenge Rate	Constant	Always changing
Fluid Used	MIL 5606	Wide variety
Temperature	100°F (38°C)	-20°F to 200°F (-7° to 93°C)
Flow	Steady	Thousands of changes

Introduction to Eaton Filtration

DIN 24550 standard is to have all filters fitted with a differential pressure indicator that gives an easy-to-read indication that the element needs to be changed. Eaton indicators are designed to indicate at a pressure drop 20% below the bypass setting which equates to 95% of the element's service life. This indication before bypass feature was incorporated to allow safe operation of the machine until the next shift change or convenient maintenance opportunity.

Element Service Life

As in any aspect of machine design or maintenance, cost of installation and operation is a very important concern. For filters, the length of time an element lasts in service, and the initial cost of that element, combine to determine the economics of using that product.

The most important aspect of gaining long element service life is to minimize the ingress! Reservoirs need to be fitted with vent filters ($\leq 3\mu\text{m}$) that remove the dirt before it enters the system. Access port and doors need to be kept sealed so that dirt cannot be drawn into the system. Cylinder rods that extend into contamination laden environments should be shielded to minimize the dirt being drawn into the system.

The second important aspect to long element service life is to keep the cleanliness level of the fluid at or below target. Periods of machine operation with dirty fluid cause accelerated internal wear that loads a filter

In poorly supported elements, changes in flow and pressure drop cause the sides of element corrugations to flex and the root to stretch, giving rise to fatigue stresses. Dirt capacity is also lost as areas of the medium have no flow.

Eaton doc. 561, page 21

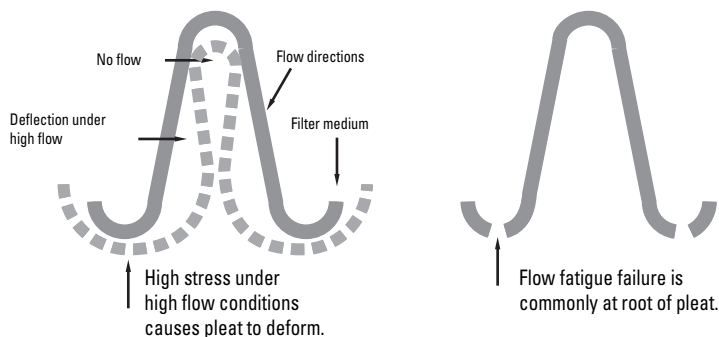

element. (It's important the debris is caught as it saves the system, but it does cost the element part of its service life.) Always change an element on indication and always use genuine Eaton elements because of their consistent performance and superior strength under stress.

The third issue in long element service life is the "dirt capacity" of the element. This value is calculated as part of the multipass efficiency test. Because of the many differences between the test conditions (Fine Test Dust [ACFTD] contamination, single pressure rise, etc.) and real system operation, different dirt capacity values do not correlate well to changes in element service life. Dirt capacity can only be used to compare elements under very specific laboratory situations, and as a result published dirt capacity values should be used as general information rather than specific comparable data.

Eaton elements are designed to give long life and reliable

service in hydraulic or lubrication applications. This is achieved with our multi-layer construction. Each layer provides additional strength or capacity leading to overall superior performance. Some elements focus heavily on media structure only, which can give increased "dirt capacity" under laboratory conditions, but no increase in service life is experienced in real systems.

An often overlooked aspect of dirt capacity and service life is the effect of element area. When comparing an element of "x" area with an element of "2x" area, one would expect twice the life for the larger element. But, in real systems, the life extension is most often between 2.5 and 3.5 times as long. This is because the reduced flow density through a unit area of media allows for more effective contaminant capture. Larger elements are the most cost effective approach to contamination control from the perspective of operating costs.

Fluid Analysis

Eaton Fluid Analysis Service

Eaton hydraulic components have an unequalled reputation for quality, reliability and performance. We built that reputation on a tradition of customer service, and stand behind every one of our products.

Our Fluid Analysis Service follows that same tradition. We provide our customers with comprehensive fluid testing and diagnostic services, with detailed reports that are easy to understand.

To find out how the Eaton Fluid Analysis Service can help your operation, read on.

Then call us to get started.

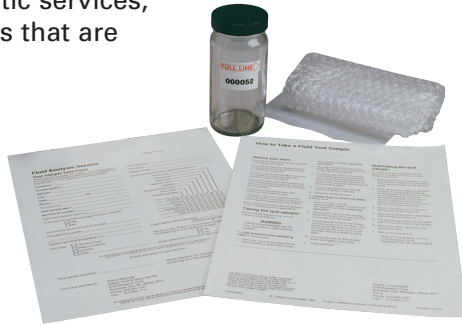

A Name You Trust

Only one fluid analysis lab lets you put years of Eaton experience to work for you. That's because nobody knows hydraulics like Eaton. So when the health of your hydraulic system is at stake, choose a partner with more than 75 years of experience. Contact your Eaton representative for more information on our Fluid Analysis Service.

Critical Analysis

Fluid is the lifeblood of every hydraulic power system. To keep yours running efficiently and effectively, you need to know what's in it. What you don't know can hurt you.

The Eaton Fluid Analysis Service analyzes hydraulic fluid in much the same way a medical lab tests a blood sample. Just as a blood test helps a doctor diagnose health problems, a sample of hydraulic fluid can help us pinpoint sources of contamination and determine whether or not your system uses adequate filtration.

We can help you reduce catastrophic equipment failures, maintain optimum component performance, and identify any substandard maintenance practices. Your bottom-line benefit is increased productivity.

Clear Benefits

We offer testing designed to tell you the most about your hydraulic fluid. We use sophisticated computer programs and laboratory diagnostic equipment such as an Energy Dispersive X-ray Fluorescence, and an inductively coupled plasma spectrophotometer.

After we use this advanced equipment to provide the most detailed possible analysis of your hydraulic fluid, we create reports that are always easy to read and understand. By taking the mystery out of fluid analysis, we provide a service that clearly explains the benefits of clean fluid.

Comprehensive Testing

The Eaton Fluid Analysis Service is certified to ISO 12025 and offers a full range of tests specifically designed for the analysis of hydraulic and lubrication system fluid. Our laboratory equipment and test procedures provide an exact analysis of your hydraulic or oil lubricated system, and our drawdown particle isolation procedure ensures accurate results.

Our testing procedures can include:

Photomicrography: We scan and photograph a filter patch using an optical microscope to find particle size and type. The scanning process verifies the automatic particle count to identify samples needing special preparation. This provides confirmation of automatic counter results, and helps us see what contaminant's are in the fluid.

Viscosity (ASTM D445):

We use this test to determine the viscosity of your oil. Without proper hydraulic fluid viscosity, your equipment will suffer. Incorrect viscosity leads to fluid breakdown, inefficient equipment operation, premature system failure, and damage to other components.



Water (ASTM E203): We determine the water content in hydraulic fluid, which helps us predict quality and performance characteristics for the fluid and system components. Excess water reduces the viscosity of hydraulic fluid, which increases the likelihood of adverse chemical reactions

and degrades equipment performance.

Drawdown Particle Isolation: Using this test,

we determine the insoluble contaminants in hydraulic fluids, both insoluble particles and gel-like matter, organics and inorganics. Used in conjunction with photomicrography, the drawdown patch helps us identify the source and type of fluid contaminant's.

Automatic Particle Count (ISO 11500):

We use a high-intensity laser light source and a photo sensor to count the number and size of particles in the fluid sample, and then define contaminant's according to size distribution and quantities. Automatic particle counting is quick, repeatable and accurate. It provides reliable information we can use to check against ISO Standard 4406, which defines the relationship between particle counts and hydraulic fluid cleanliness. This lets us determine exactly what

corrective actions—if any—are needed. The lab is also capable of testing to the new ISO 4406(1999) standard (4 μ , 6 μ , 14 μ).

Spectrometric Analysis (ASTM D 5185):

This shows us the concentration of oil-soluble elements, and indicates the additives and trace metal content in the fluids. We use this technique to evaluate the condition of the additives in a fluid rather than its particulate contamination. Used in conjunction with automatic particle counting, it helps us accurately assess the cleanliness level of the fluid.

Energy Dispersive X-ray Fluorescence (ASTM E 1508):

We perform Energy Dispersive X-ray Fluorescence (XRF) analysis on samples with extremely high concentrations of particulate contamination. By isolating chemical elements, we pinpoint contaminant types so we can establish their origins, and so you can take corrective action.

Fluid Analysis

Easy-to-Read Reports

We present your fluid test results in a format that is easy to understand. Results typically include these items:



Vacuum Pump PN 894279

1. Results Target: A results target compares your actual fluid cleanliness results and your ideal cleanliness level. If you don't have a target level yet, we can use your sample to help you determine what it should be.

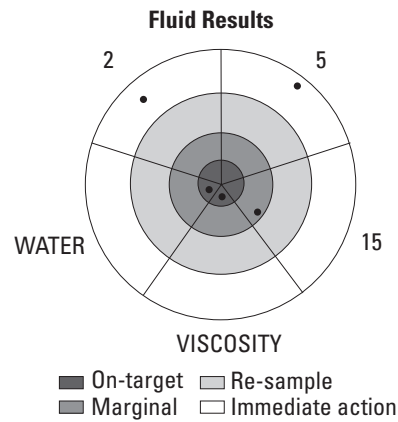

2. Trend Information: We evaluate data from your previous two samples along with the results of your current sample. This provides a trend analysis of critical measurements, and shows changes in the fluid over time.

pH (ASTM E 70) represents the strength of acidity in hydraulic fluid, and is usually measured for water-containing hydraulic fluids (water/glycols, invert emulsions). Typical values are 8.5–10.5.

Total Acid Number, or **TAN (ASTM D 974)**, is the amount of acid and acid-acting material constituents in hydraulic fluid. An increase in TAN indicates oxidation or acid contamination. Some hydraulic fluids exhibit higher acid numbers than others. Typical values are 0.1–3.0.

TEST 2 Time	TEST 3 Present	Previous #1	TEST 1 Previous #2
Viscosity @ 100°F cSt (SUS)	45.0 (210)	45.5 (212)	45.8 (213)
Water % Weight	0.03%	0.03%	0.03%
pH	9.4	9.5	9.6
Note: pH is for water containing fluids only.			
TAN mg KOH/gm	2.1	2.0	2.1
Note: TAN is for synthetic fluids only.			

Particle Count Summary

Time	TEST 1 Present	TEST 2 Previous #1	TEST 3 Previous #2
>2µ	65,120	4,100	418
>5µ	12,220	1,250	88
>10µ	5,800	700	39
>15µ	900	250	22
>25µ	125	60	4
>50µ	12.0	5.0	1.0
Cleanliness Code	23/21/17	19/17/15	16/14/12

KIT FEATURES

Kit Part #	Automatic Particle Count ISO 11500	Water ASTM E203	TAN/PH (if applicable)	Viscosity ASTM D445	Photo Microscopy Drawdown Particle Isolation	Energy Dispersive XRF ASTM E1508 (if applicable)	Spectrographic Analysis ASTM D5185
924609	•	•	•	•	•		
894276	•	•	•	•			
3039604	•	•	•	•		•	•
894277	•	•	•	•	•	•	•
894279	Vacuum pump for extracting oil sample						

Each kit includes:

- Super clean sample bottle
- Packaging for sending sample
- Numbered test sample data form
- Fluid analysis service

Items not in bold are non-standard and may have a longer lead time

Fluid Analysis

Cleanliness Code Graph

3. Cleanliness Code Graph:

This graph uses the ISO 4406 standard for measuring and depicting the amount and size of particles per milliliter in hydraulic fluid, shown in a log-log2 graph that charts the amount of particles greater than certain micron sizes per milliliter of fluid.

Recommendations: This section of the report provides you with valuable information on the cleanliness of your hydraulic system, as well as tips on maintaining or improving its current condition.

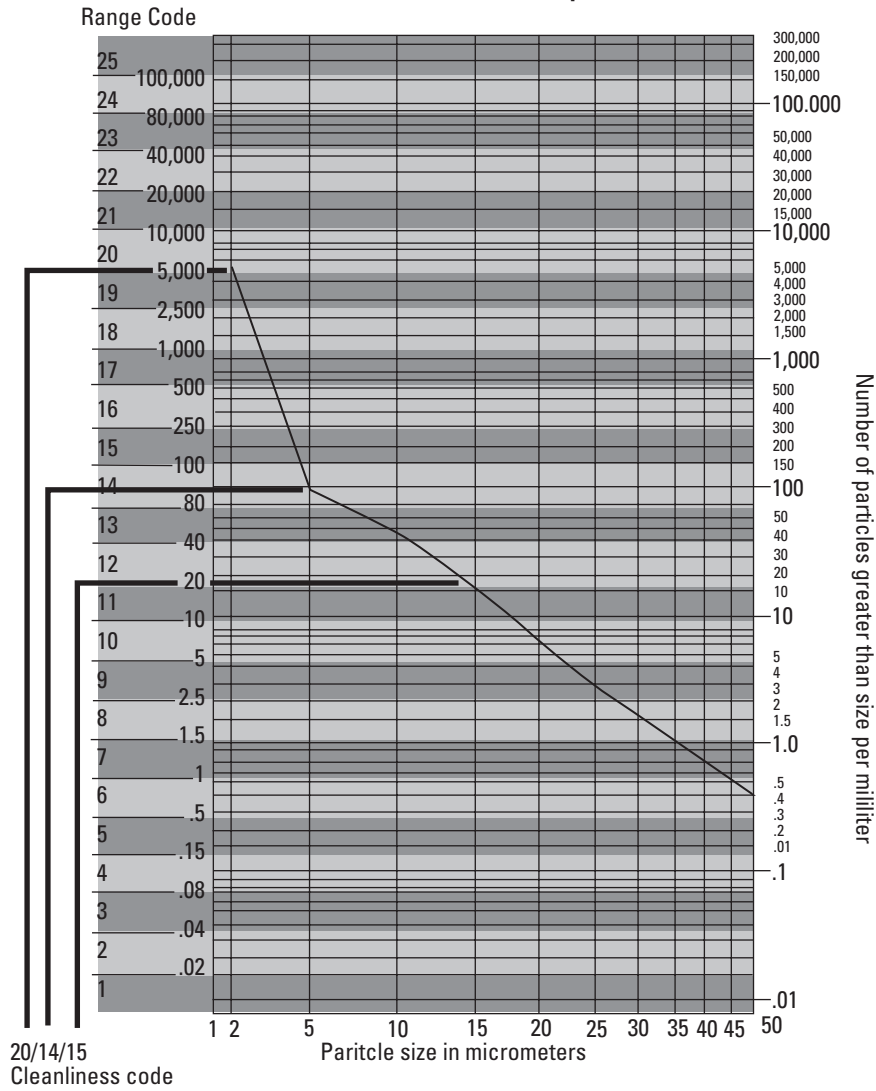

Sample XRF Analysis Results

When a fluid sample shows high particulate contamination, we use Energy Dispersive X-ray Fluorescence (XRF) analysis to isolate and identify chemical elements. The results are shown in a graph like this.

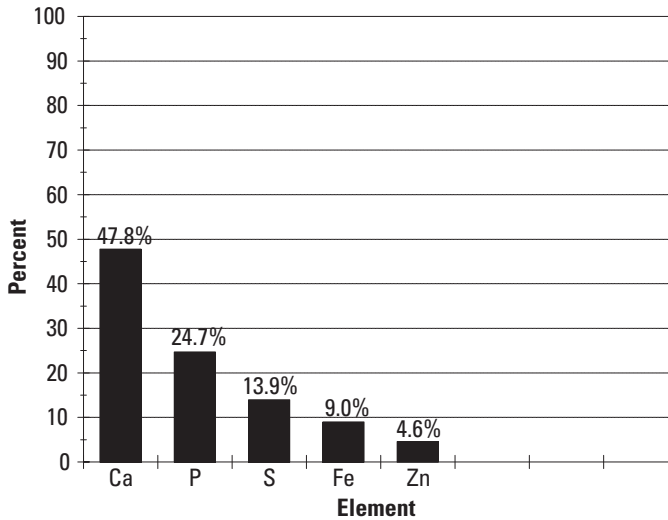

Particle Counter

Target Pro 2

Lab Quality in the Field

Eaton's Target-Pro 2 Portable Particle Counter gives you laboratory quality particle count results in the field. It combines state-of-the-art laser particle counting technology with a user-friendly interface and compact size. It allows you to monitor the fluid cleanliness of hydraulic and lubrication systems, and take action if necessary.

The Eaton Method of Systemic Contamination ControlSM:

1. Set a Target Cleanliness Level for the system.
2. Achieve the Target Cleanliness by appropriate filter selection and placement.
3. Maintain the Target Cleanliness by monitoring the system and taking action as necessary.

The Target-Pro 2 includes two rolls of thermal paper, one waste bottle, one waste hose, one pressure hose, one power adapter, one RS-232 serial cable, and Target-Pro 2 software for Windows. A Bottle Sampler is available as an option.

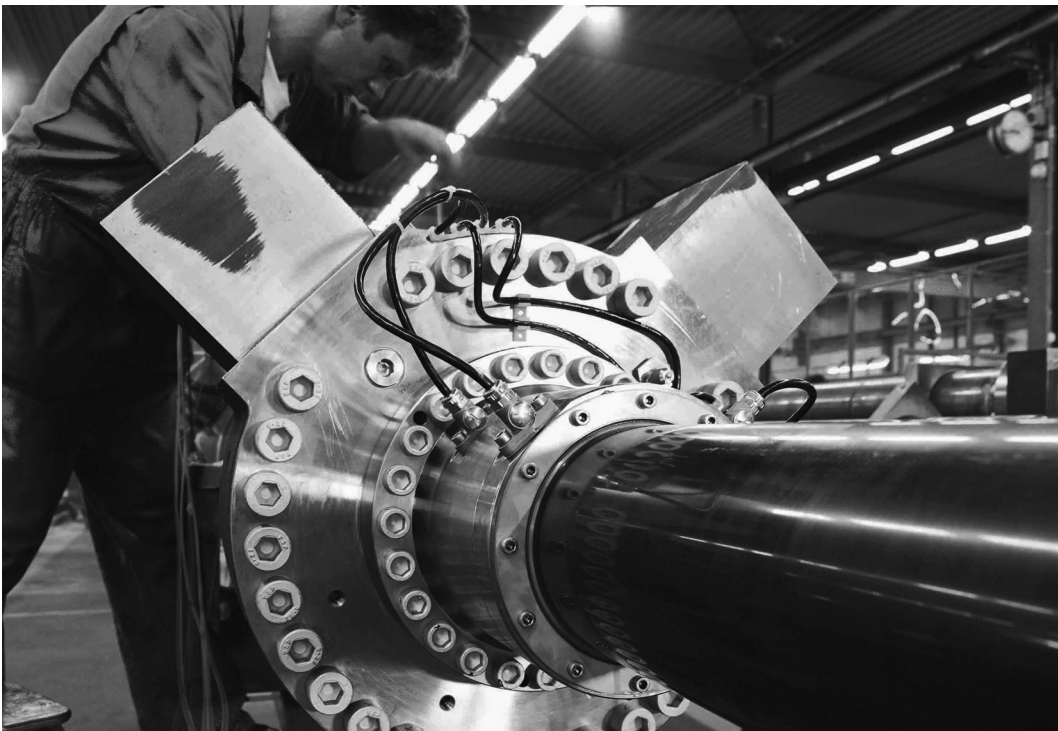

The Target-Pro 2 measures and quantifies solid contaminant's in hydraulic, lubrication and transmission applications. It is designed to provide laboratory accuracy at the job site, whether your application is mobile or stationary.

Particle Counter

Target Pro 2

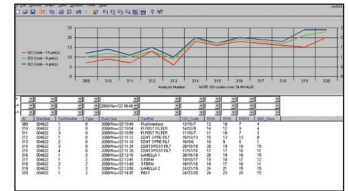

Target-Pro 2 software for Windows, included with the analyzer, allows you to download test results and analyze cleanliness trends over time.

TECHNICAL INFORMATION

Technology	Automatic Optical Particle Analyzer
Laser Package	Twin Laser and Twin Optical Diode Detectors
LCD display	(backlit)
Sensitivity	>4, 6, 14, 21, 25, 38, 50, 68 $\mu\text{m(c)}$, Micron range to revised ISO 4406 Standard
Accuracy/Repeatability	Better than 3% typical
Calibration	Each unit is individually calibrated with ISO Medium Test Dust (MTD) to ISO 11171:1999 on equipment certified by I.F.T.S.
Analysis Range	ISO 8 to ISO 24 to ISO 4406 (NAS 1638-2 to 12)
Report/Print Format	ISO and NAS codes, with individual particle counts as a built-in option
Printer	Fixed head thermal printer (384 dots per line)
Target-Pro 2 Sample Volume	15 ml. (normal), 30 ml. (dynamic) 24 ml. (bottle sampler) 15 ml. (continuous), 8ml. (short)

Operation	Max. system working pressure, 400 bar; Min. working pressure, 2 bar
Viscosity Range	to 400 centistokes
Operating Temperature	+5 to +80°C
Fluid Compatibility	Mineral oil and petroleum based fluids (consult Eaton for other fluids)
Typical Test Time	Result in <2.5 mins. (normal test)
Power	Internal rechargeable battery (AC charger) or external 12/24 volt DC power supply
Data Storage	600 tests
Computer Interface	RS-232 (serial) communication port
Hose Connections	minimess fittings microbore hose, 1.5 m waste fluid hose
Dimensions	Height 210mm; Depth 260mm; Width 430mm; Weight 7.6 kg

Note:

The Target-Pro should only be operated on petroleum based fluids, synthetic or biodegradable fluids. For phosphate esters, Skydrol®, crankcase fluids with high soot content, or water glycol, please consult Eaton.

Breathers

Hydraulic reservoirs “breathe” air in and out as the oil level rises and falls. This circulating air contains particles and moisture that can cause corrosion, increase equipment wear and reduce fluid performance. In typical systems, the internal hydraulic fluid is warmer than the external environment. This difference in temperatures causes water vapor to form. Breathers protect your hydraulic system by filtering out damaging moisture and particles.

More than 25% of the samples sent to the Eaton Fluid Analysis Laboratory for analysis have significant water contamination. In an operating system, the H2O-gate Vent Breather creates a moisture barrier when there is a 5°F (2°C) difference between reservoir and ambient temperature and when there is a 10% per minute exchange of air volume above the fluid. The Mobile-gate breather is smaller in size but is also 1/4 the size and 1/2 the capacity of the H2O-gate. These temperature and air flow conditions are present in most hydraulic systems which employ a cylinder.

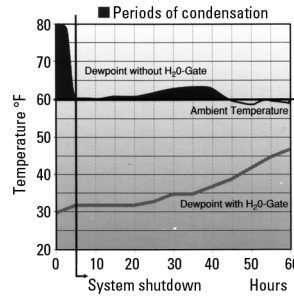
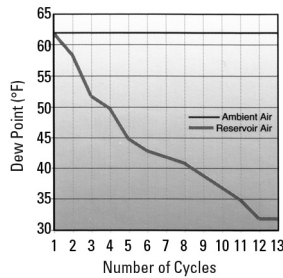
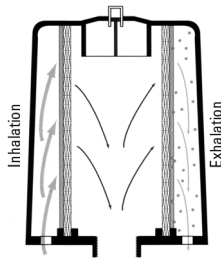

Part Numbers:

NPT Mobile-gate	MBR110
Flange Mobile-gate	MBR120
H2O-gate	BR110
Dirt-gate	BR210

Performs as a gate

During the “inhalation” cycle, the proprietary media blocks the water vapor from entering the reservoir. During the “exhalation” cycle, the media allows the moisture in the reservoir air to exit. The moisture is carried off the media by the exiting air, restoring the media’s water barrier capacity, and the moisture barrier mechanism is not affected by the amount of exposure to moisture. The reservoir air is maintained at a low relative humidity, and more importantly, at a lower dew point temperature than the ambient temperature.

Works even when the system is shut down.

The H2O-gate and Mobile-gate Vent Breather retard the vapor equilibrium process and work to prevent condensation even after the system is shut and cooled down, such as overnight. As this chart illustrates, the dewpoint is slow to climb, even after the system temperature has dropped to the ambient temperature. Once the system has reached ambient temperature, condensation does not occur.

Reduces humidity inside reservoir.

The H2O-gate and Mobile-gate Vent Breathers lower and stabilize the relative humidity of air inside the reservoir, leading to a lower dewpoint (Tdewpoint < Tambient = NO CONDENSATION) at a rate and amount that will be dependent upon several conditions: the ambient conditions, the internal reservoir heat, amount and frequency of reservoir air flow through the vent, and the temperature of the reservoir surfaces.

BREATHER FEATURES

	H₂O-gate	Dirt-gate	Mobile-gate
Visual Indicator	•	•	•
Particle Control	•	•	•
Water/Moisture Control	•	•	•
Corrosion Resistant Housing	•	•	•
Flow Rate	708 L/min (187 USgpm)	708 L/min (187 USgpm)	473 L/min (125 USgpm)

Breathers

H2O-gate™ Reservoir Breather

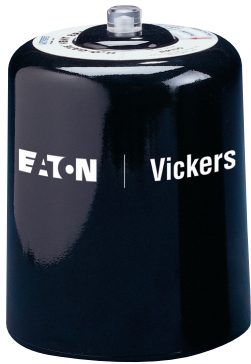

Features/Benefits:

- Visual Mechanical Indicator: Actuates when particles have blocked the media, before the pump cavitates.
- Proprietary Media: Reduces dew point temperature to prevent condensation and is 99.7% efficient in blocking particles 3µ and larger.
- Reversible Flow Through Media: Allows for moisture to exit the reservoir.
- Media contains oil attractant layer to collect and return oil splashes.
- Easy Installation: Lightweight design can be hand tightened onto adapter.
- Durable Plastic Housing: Protects the media from external splashing.
- Superior breather filters both moisture and particles from air.
- Effective up to 121°C (250°F)
- Media contains oil attractant layer to collect and return oil splashes.
- Rated up to 25 SCFM

Part Numbers:

H2O-gate	BR110
Bayonet Adapter	924710
Screw-in Adapter	P-077002

Dirt-gate™ Reservoir Breather



Features/Benefits:

- Visual Mechanical Indicator: Actuates when particles have blocked the media, before the pump cavitates.
- Easy Installation: Lightweight design can be hand tightened onto adapter.
- Durable Plastic Housing: Protects the media from external splashing.
- High Efficiency: (99% at 2 microns)
- Very Low Pressure Drop
- Filters out particles
- Effective up to 121°C (250°F)
- Rated up to 25 SCFM

Part Numbers:

Dirt-gate	BR210
Bayonet Adapter	924710
Screw-in Adapter	P-077002

Note:

This breather does not filter moisture from air.

Mobile-gate™ Filler Breather Assemblies



MBR110

MBR120

Features/Benefits:

- Proprietary Media: Reduces dew point temperature to prevent condensation and is 99.7% efficient in blocking particles 10µ and larger.
- Water Barrier: Regenerates its water shedding capacity with each cycle.
- Reversible Flow Through Media: Allows for moisture to exit the reservoir.
- Easy Installation: Lightweight design can be hand tightened.
- Rugged metal housing is long lasting and ideal for mobile applications.
- Rated to 16.7 SCFM

Part Number

MBR110	5002486
MBR120	5002487

Items not in bold are non-standard and may have a longer lead time

Breathers

H2O-gate Specifications

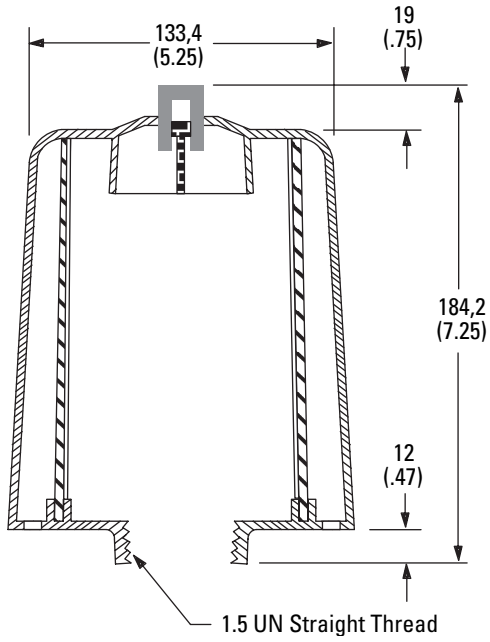

Dirt-gate Specifications

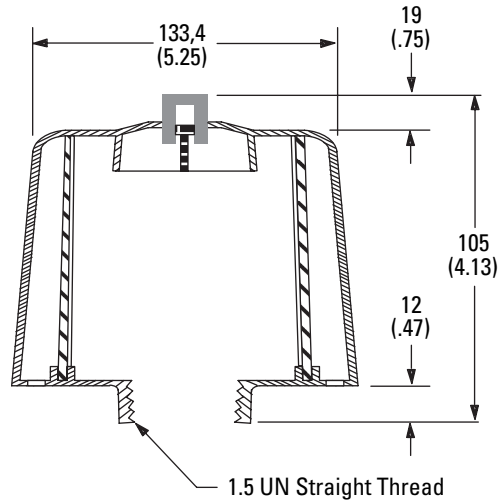

Mobile-gate Specifications

PART NUMBER	FLOW		DIMENSIONS (IN)						
	USgpm	L/min	D1	D2	D3	D4	H1	H2	T1
MBR110	125	475	3.08	-	-	-	2.33	0.63	NPT 3/4
MBR120	125	475	3.08	1.88	-	-	2.50	3.50	-
MBR120 FLANGE	-	-	-	-	0.25	2.81	-	-	-

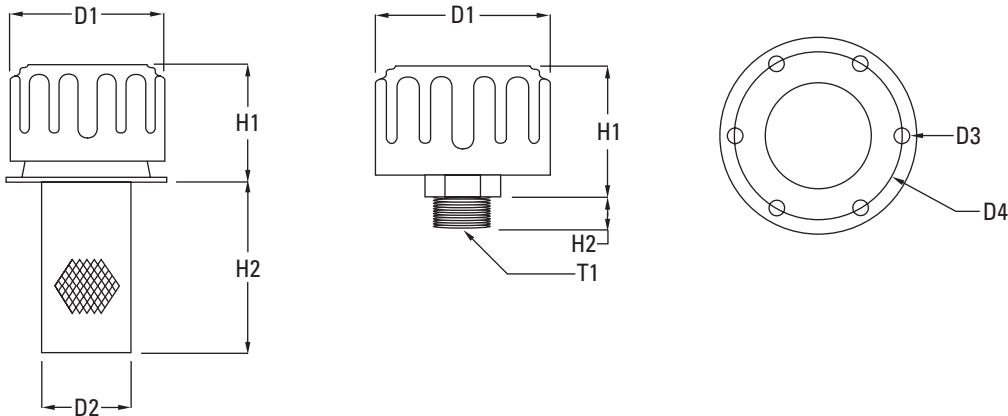

Breathers

Adapters

Installation Dimensions

Threaded Pipe Adaptor

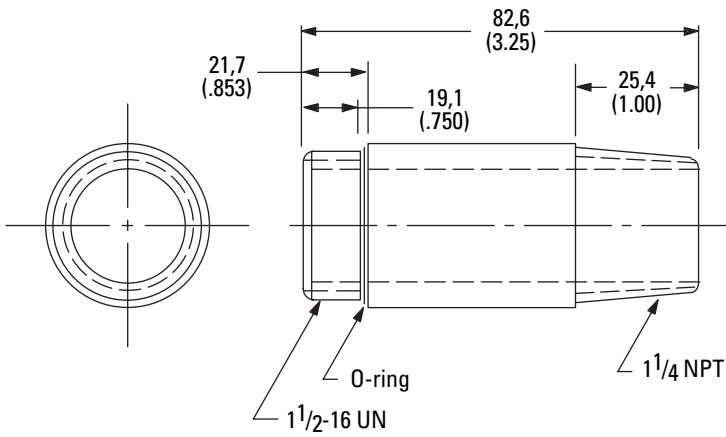

MODELS AND PART NUMBERS

Part Number	Description	Vent Filters Applicable
924710	Bayonet, no check	BR110, BR210
P-077002	Threaded pipe	BR110, BR210

Bayonet Adaptor

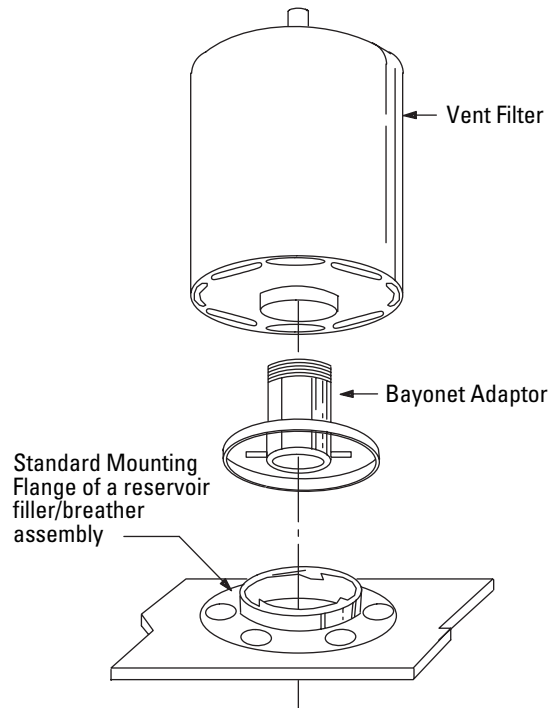

All Eaton Vent Filters are easily applied to reservoirs via Spin-On adaptors.

Return Line Filters

General Data

Return line filters usually have spin-on type elements, cartridge elements in an in-line mounted housing, or cartridge elements within a housing that is mounted directly within the reservoir itself (sometimes referred to as an in-tank filter).

Return line filters may also be equipped with fluid sampling devices to monitor the fluid cleanliness level. Secondary ports may also be incorporated to add make-up fluid and ensure that the fluid is transferred through a filter before entering the system.

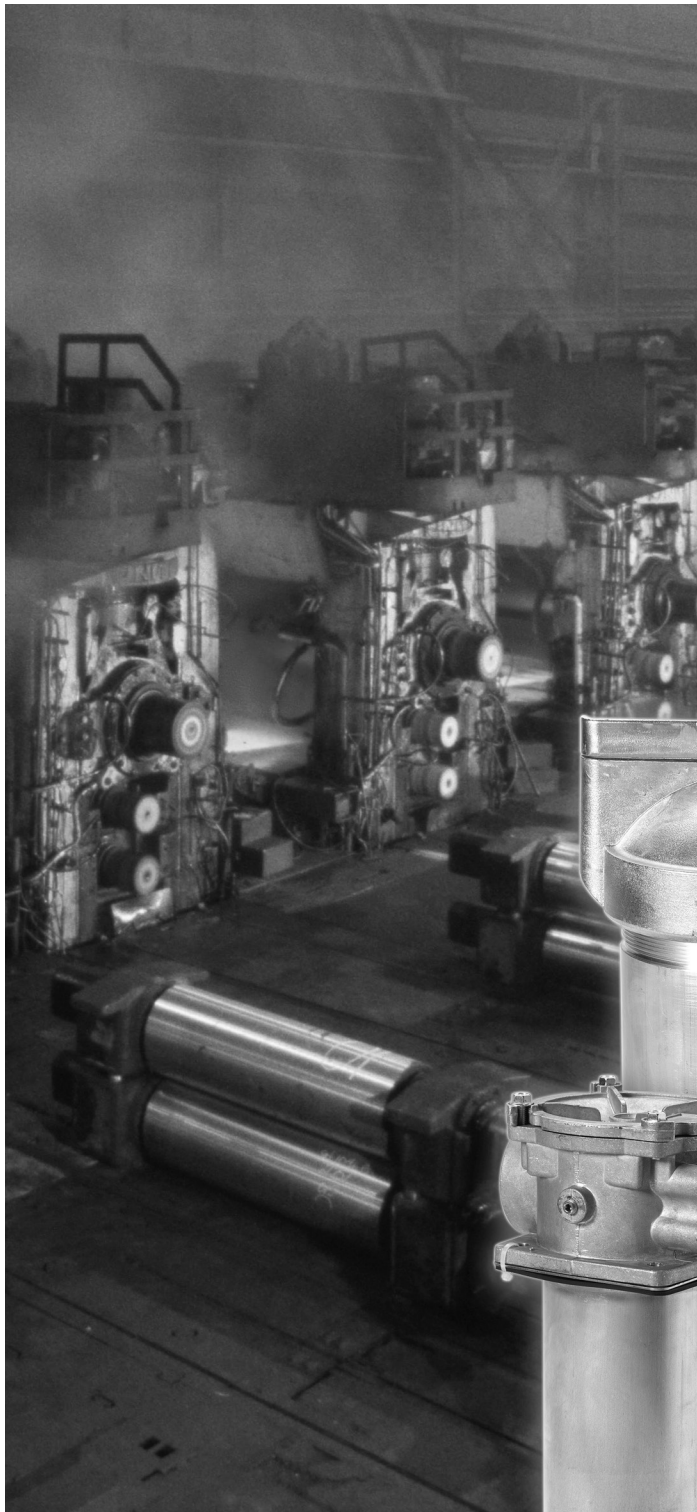

Return line filters are:

- An integral part of an effective contamination control solution.
- Ideal for systems where the pump is the sensitive component
- An economic means achieving the target cleanliness level
- Often placed before the fluid enters the reservoir in order to prevent debris and particles from recirculating through the system
- A crucial component when cylinders are present in the system. Cylinders potentially contribute a large amount of contamination ingress and return line filters are ideal for this type of control solution.
- Sometimes the only filters necessary (combined with a breather) when seeing the entire system flow on a continuous basis
- Only a part of an effective contamination control solution when the system employs variable displacement pumps. Filters in systems like this may be supplemented by pressure and/or off-line filters

Applications

- Stroke boom delimiters
- Drilling platforms
- Die cast machines/ injection molding
- Large machine tools

Return Line Filters

HV3R Series

Flows to 280 L/min (75 USgpm)
Pressures to 50 bar (725 PSI)



Features and Benefits

- Designed to comply with ANSI specifications and ISO cleanliness standards.
- Visual, electrical, and electrical indicators with lamp options for system design flexibility
- Fully serviceable without tools
- Zero leak by-pass valve construction.
- Wide range of element lengths for maximum design flexibility
- High efficiency replacement elements in standard configurations (C-Pak) to meet Target Cleanliness Levels
- High collapse elements available for non-bypass applications.

DESIGN SPECIFICATIONS

Rated flow:	Length 1	160 L/min (42 USgpm)
	Length 2	240 L/min (63 USgpm)
	Length 4	280 L/min (74 USgpm)
Fluid compatibility:	Compatible with most petroleum oil, oil-in-water and water-in-oil fluids Optional seals available for phosphate esters.	
Temp range:	-30°C to 121°C (-22°F to 250°F)	
Pressure rating:	Operating	50 bar (725 PSI)
	Fatigue	50 bar (725 PSI)
Material:	Head	Aluminum
	Bowl	Carbon Steel
	Collar	Carbon Steel
Dry weight: (Approximate)	Length 1	2,3 kg (5.1 lbs)
	Length 2	2,5 kg (5.5 lbs)
	Length 4	3,4 kg (7.5 lbs)

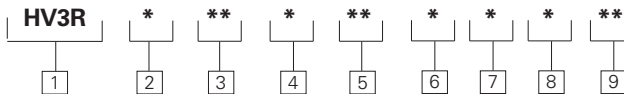

HV3R Series Filter and Element Model Code

Sample model code:

HV3R1SC4RLB2C05

1 Filter Series - HV3R

2 Element Collapse Rating

- 1** - 250 PSI Low Collapse
4 - 3000 PSI High Collapse

3 Port Options

- BC** - G 1-1/4 to ISO 228
SC - 1.625 - 12UN SAE-20 str. Thd. (1-1/4" tube)

4 Valve Options

- 1** - Non-Bypass
4 - Bypass set at 43 PSI cracking pressure
6 - Bypass set at 87 PSI cracking pressure

5 Indicator Options

- AN** - Visual 70 PSI, No Connector
KN - Visual 15 PSI, No Connector
LN - Visual 30 PSI, No Connector

JN - No Indicator (plug), No Connector

RB - Electrical 30 PSI, Brad Harrison

RJ - Electrical 30 PSI, Hirshman w 24 volt light

RK - Electrical 30 PSI, Hirshman w 115 volt light

RL - Electrical 30 PSI, Hirshman w 230 volt light

RH - Electrical 30 PSI, Hirshman

UB - Electrical 70 PSI, Brad Harrison

UJ - Electrical 70 PSI, Hirshman w 24 volt light

UK - Electrical 70 PSI, Hirshman w 115 volt light

UL - Electrical 70 PSI, Hirshman w 230 volt light

UH - Electrical 70 PSI, Hirshman

6 Seal Material

- B** - Buna-N
V - Viton-A

Viton is a registered trademark of E.I. DuPont

7 Assembly Length

mm (inch)

- 1** - 207 (8.15)
2 - 266 (10.47)
4 - 447 (17.6)

8 Element Construction

- C** - 250 PSI Low Collapse
H - 3000 PSI High Collapse

9 Fluid Cleanliness Rating

Code **Target fluid cleanliness level**

03 16/14/12 or better

05 18/16/14 or better

10 20/18/15 or better

20 22/19/16 or better

Return Line Filters

HV3R Series

Flows to 280 L/min (75 USgpm)
Pressures to 50 bar (725 PSI)

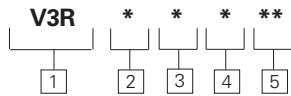

V3R Element Model Code

Sample model code:
V3RB1C05

1 Filter Element

V3R - For use with HV3R series housings

2 Seal Material

B - Buna-N
V - Viton-A

3 Element Length

mm (inch)
1 - 114 (4.5)
2 - 173 (6.8)
4 - 356 (14)

4 Element Construction

C - C-Pak (grade 3, 5, 10, 20)
H - H-Pak (grade 3, 5, 10)

5 Fluid Cleanliness Rating

Code	Target fluid cleanliness level
03	16/14/12 or better
05	18/16/14 or better
10	20/18/15 or better
20	22/19/16 or better

Housing Dimensions

mm (inch)

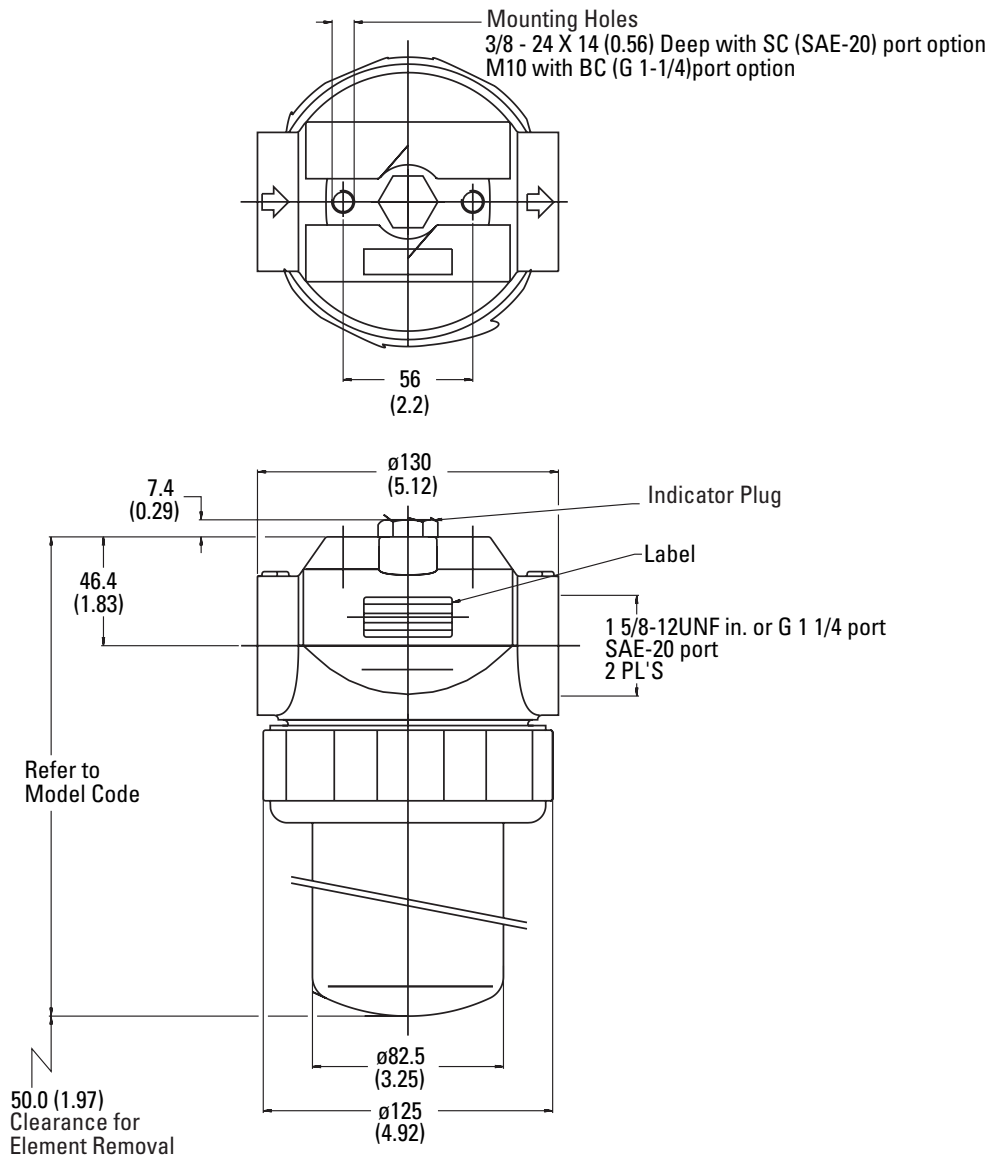

Items not in bold are non-standard and may have a longer lead time

Return Line Filters

Flows to 280 L/min (75 USgpm)
Pressures to 50 bar (725 PSI)

HV3R Series

Flow versus pressure drop:

150 SUS (32 cSt) oil with specific gravity of ≤ 0.9

Flow Data

Element Flow Data

HV3R C-Pak Length 1

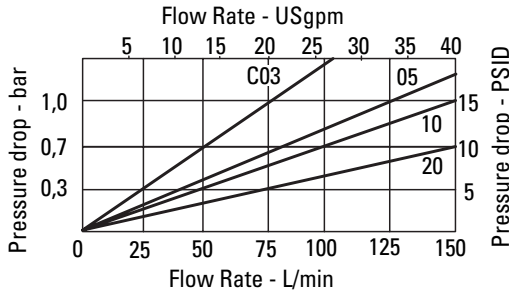

HV3R H-Pak Length 1

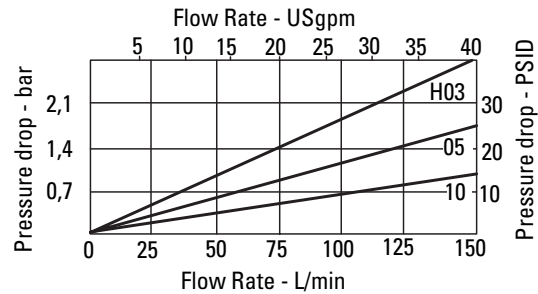

HV3R C-Pak Length 2

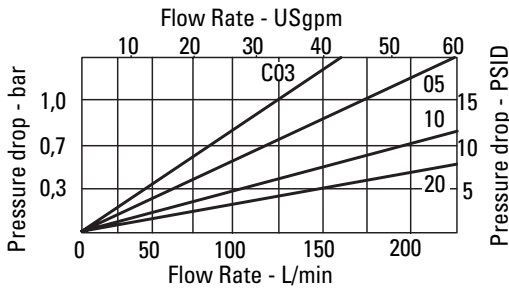

HV3R H-Pak Length 2

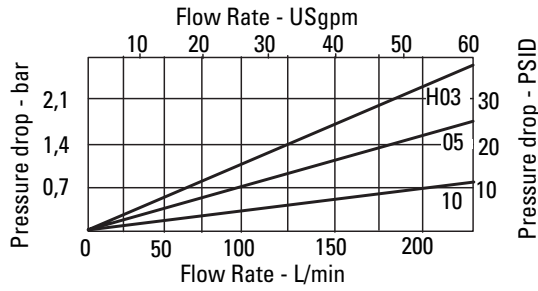

HV3R C-Pak Length 4

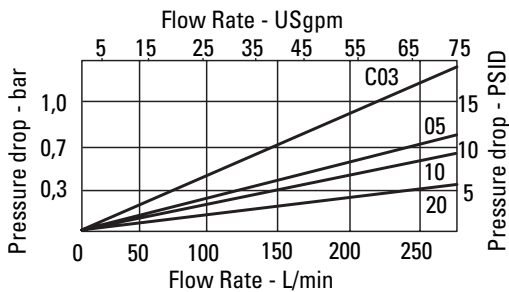

HV3R H-Pak Length 4

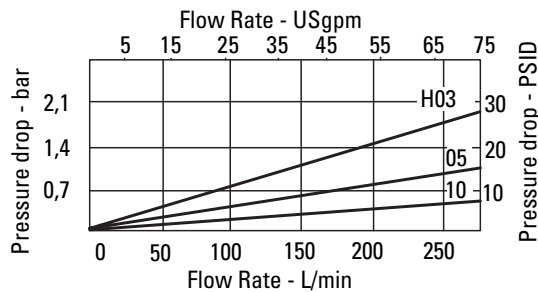

Housing/Bypass Valve Flow Data

Housing

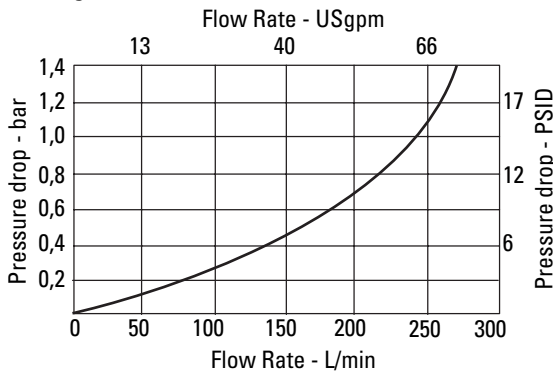

Bypass Valve

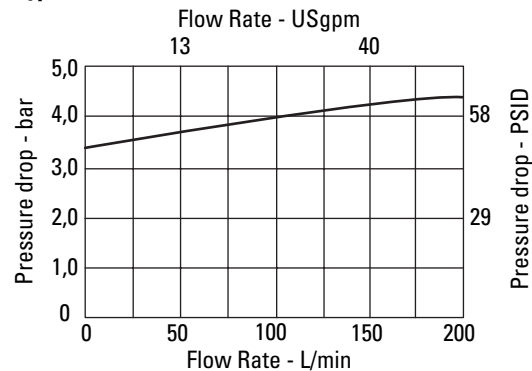

Return Line Filters

HV6R Series

Flows to 1700 L/min (450 USgpm)
Pressures to 25 bar (360 PSI)



Features and Benefits

- Designed to comply with ANSI specifications and ISO cleanliness standards.
- Easy to remove cap to facilitate element change and minimize spillage.
- Vent and drain ports to facilitate maintenance and system start-up.
- Delta P visual, electrical, and electrical indicators with lamp options for system design flexibility.
- High efficiency replacement elements in standard configurations (C-Pak).

DESIGN SPECIFICATIONS

Rated flow:	Length 5	1300 L/min (343 USgpm)
	Length 8	1700 L/min (450 USgpm)
Fluid compatibility:	Compatible with most petroleum oil, oil-in-water and water-in-oil fluids. Optional seals available for phosphate esters.	
Temp range:	-30°C to *121°C (-22°F to *250°F)	
Pressure rating:	Operating	25 bar (360 PSI)
	Fatigue	25 bar (360 PSI)
Material:	Head, Housing, Lid Aluminum	
Dry weight: (Approximate)	Length 5	17 kg (37 lbs)
	Length 8	23 kg (50 lbs)

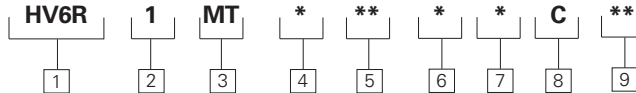

HV6R Series Filter and Element Model Code

Sample model code:

HV6R1MT4RLB8C05

1 Filter Series - HV6R

2 Element Collapse Rating

1 - 250 PSI Low Collapse

3 Port Options

MT - 4" SAE 4 Bolt Flange with Metric threads (M16 bolts provided)

4 Valve Options

- 1** - Non-Bypass
- 2** - Bypass set at 25 PSI cracking pressure
- 4** - Bypass set at 43 PSI cracking pressure

5 Indicator Options

- AN** - Visual 70 PSI, No Connector
- KN** - Visual 15 PSI, No Connector
- LN** - Visual 30 PSI, No Connector

JN - No Indicator (plug), No Connector

RB - Electrical 30 PSI, Brad Harrison

RJ - Electrical 30 PSI, Hirshman w 24 volt light

RK - Electrical 30 PSI, Hirshman w 115 volt light

RL - Electrical 30 PSI, Hirshman w 230 volt light

RH - Electrical 30 PSI, Hirshman

UB - Electrical 70 PSI, Brad Harrison

UJ - Electrical 70 PSI, Hirshman w 24 volt light

UK - Electrical 70 PSI, Hirshman w 115 volt light

UL - Electrical 70 PSI, Hirshman w 230 volt light

UH - Electrical 70 PSI, Hirshman

6 Seal Material

- B** - Buna-N
- V** - Viton-A

7 Assembly Length

- mm (inch)
- 5** - 606 (23.9)
- 8** - 1045 (41.1)

8 Element Construction

- C** - Standard Construction

9 Fluid Cleanliness Rating

Code	Target fluid cleanliness level
03	16/14/12 or better
05	18/16/14 or better
10	20/18/15 or better
20	22/19/16 or better

Items not in bold are non-standard and may have a longer lead time

Return Line Filters

HV6R Series

Flows to 1100 L/min (300 USgpm)
Pressures to 25 bar (350 PSI)

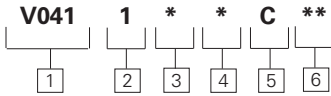

V041 Element Model Code

Sample model code:

V0411B5L03

1 Filter element

V041 - For use with HV6R series housings

2 Element collapse rating

1 - 250 PSI Low Collapse

3 Seal material

B - Buna-N
V - Viton-A

4 Element length

mm (inch)
5 - 406 (16)
8 - 990 (39)

5 Element construction

C - C-Pak (grade 3, 5, 10, 20)

6 Fluid cleanliness rating

Code	Target fluid cleanliness level
03	16/14/12 or better
05	18/16/14 or better
10	20/18/15 or better
20	22/19/16 or better

Housing Dimensions

mm (inch)

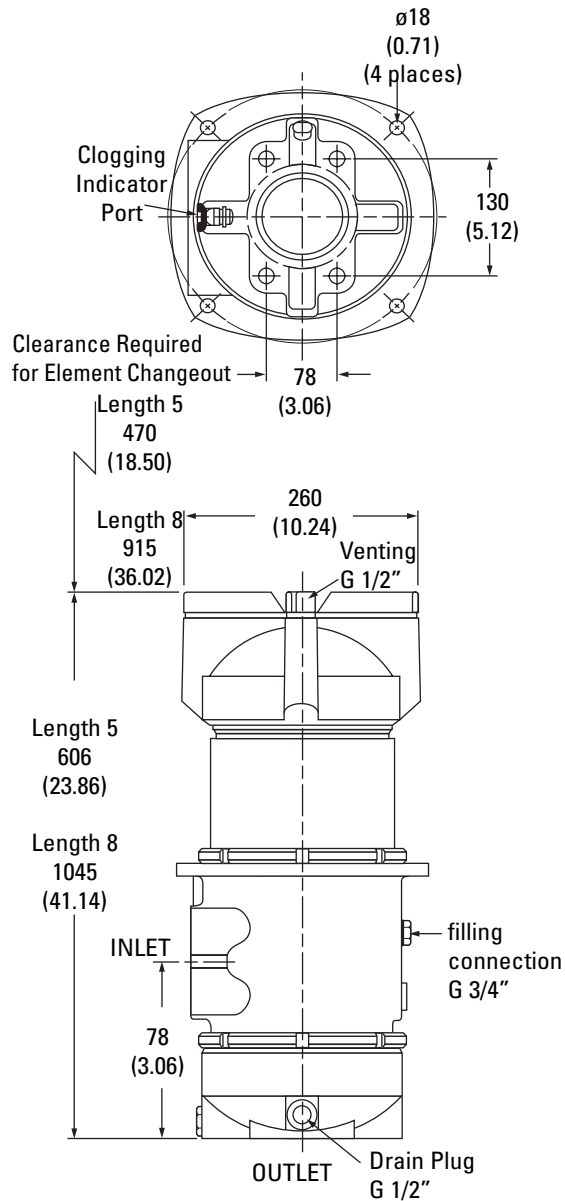

Items not in bold are non-standard and may have a longer lead time

Return Line Filters

HV6R Series

Flow Data

Flows to 1100 L/min (300 USgpm)
Pressures to 25 bar (350 PSI)

Flow versus pressure drop:

150 SUS (32 cSt) oil with specific gravity of ≤ 0.9

Element Flow Data

HV6R C-Pak Length 5

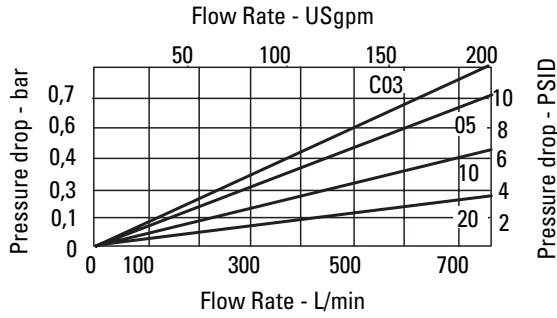

HV6R C-Pak Length 8

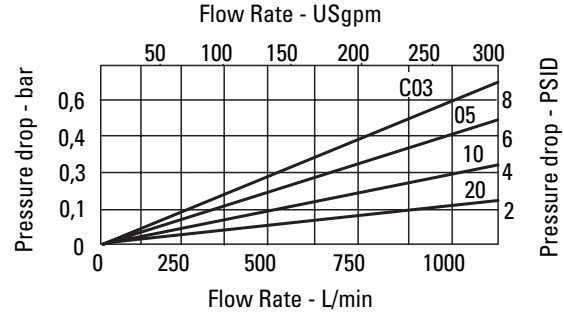

Housing/Bypass Valve Flow Data

Housing

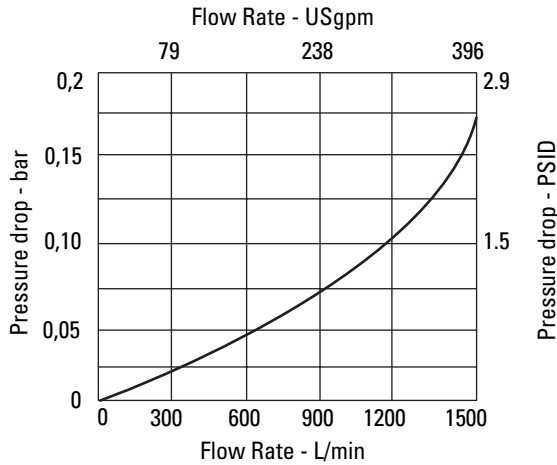

Bypass Valve

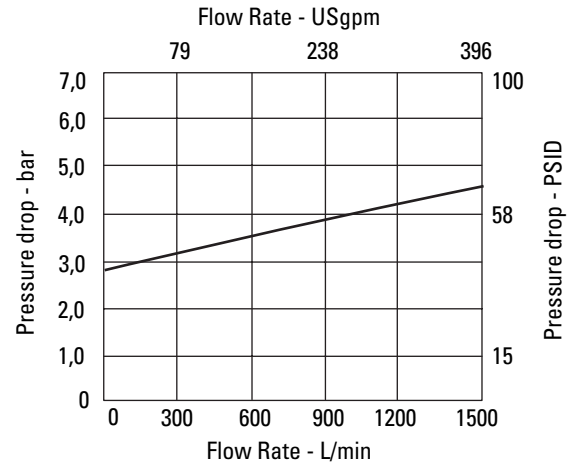

Return Line Filters

HV6RD Series

Flows to 1700 L/min (450 USgpm)
Pressures to 25 bar (360 PSI)



Features and Benefits

- Extremely large filtration area and flow capacity
- Designed for both in-tank and inline applications
- Easy filter replacement using screw-on lid.
- Vent and drain ports are standard.
- Anodization is not required for aluminum alloy when using water based fluids.
- Reusable contamination basket prevents re-entry of retained contaminant's into the reservoir during element replacement.
- Filters can be fitted with clogging indicators to monitor the contamination level of the element
- HV6RD duplex filters have a ball-type selector valve to provide continuous filtration and eliminate the need to shut-down the system during element changeout.

DESIGN SPECIFICATIONS

Rated flow:	Length 1	1300 L/min (343 USgpm)
	Length 2	1700 L/min (450 USgpm)
Fluid compatibility:	Compatible with most petroleum oil, oil-in-water and water-in-oil fluids. Optional seals available for phosphate esters.	
Temp range:	-30°C to +121°C (-22°F to +250°F)	
Pressure rating:	Operating	25 bar (360 PSI)
	Fatigue	25 bar (360 PSI)
Material:	Head	Aluminum
	Housing	Aluminum
	Manifolds	Ductile Iron
Dry weight: (Approximate)	Length 1	33,6 kg. (74 lbs)
	Length 2	79,8 kg. (176 lbs)

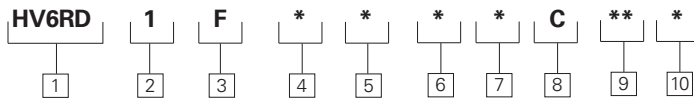

Series HV6RD Filter Model Code

Sample model code:

HV6RD1F2AB1C05

Note:

Elements used in the HV6RD are not dimensionally equivalent to elements in the HV6R series. An indicator is supplied for each side.

1 Filter Series - HV6RD

2 Element Collapse Rating

1 - 250 PSI Low Collapse

3 Port Options

F - Flanged

4 Valve Options

- 1 - Non-Bypass
- 2 - Bypass set at 25 PSI pressure
- 4 - Bypass set at 43 PSI cracking
- 6 - Bypass set at 87 PSI pressure

5 Indicator Options

- AN** - Visual 70 PSI, No Connector
- KN** - Visual 15 PSI, No Connector
- LN** - Visual 30 PSI, No Connector
- JN** - No Indicator (plug), No Connector
- MB** - Electrical 15 PSI, Brad Harrison

MJ - Electrical 15 PSI, Hirshman w 24 volt light

MK - Electrical 15 PSI, Hirshman w 115 volt light

ML - Electrical 15 PSI, Hirshman w 230 volt light

MH - Electrical 15 PSI, Hirshman

RB - Electrical 30 PSI, Brad Harrison

RJ - Electrical 30 PSI, Hirshman w 24 volt light

RK - Electrical 30 PSI, Hirshman w 115 volt light

RL - Electrical 30 PSI, Hirshman w 230 volt light

RH - Electrical 30 PSI, Hirshman

UB - Electrical 70 PSI, Brad Harrison

UJ - Electrical 70 PSI, Hirshman w 24 volt light

UK - Electrical 70 PSI, Hirshman w 115 volt light

UL - Electrical 70 PSI, Hirshman w 230 volt light

UH - Electrical 70 PSI, Hirshman

6 Seal Material

B - Buna-N
V - Viton-A

7 Assembly Length

mm (inch)
1 - 606 (24)
2 - 1045 (41)

8 Element Construction

C - Standard Construction

9 Fluid Cleanliness Rating

Code	Target fluid cleanliness level
03	16/14/12 or better
05	18/16/14 or better
10	20/18/15 or better
20	22/19/16 or better

10 Facing Indicator Flow Path

A - Front inlet, front outlet
B - Front inlet, back outlet
C - Top inlet, front outlet
D - Top inlet, bottom outlet

Return Line Filters

HV6RD Series

Flows to 1700 L/min (450 USgpm)
Pressures to 25 bar (360 PSI)

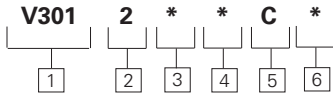

V301 Element model code

Sample model code:
V30112B1C10

1 Filter Element - V301

2 Element Collapse Rating
2 - 250 PSI Collapse

3 Seal Material
B - Buna-N
V - Viton-A

4 Element Length

mm (inch)
1 - 254 (10)
2 - 693 (27)

5 Element Construction

C - C-pak (grade 3, 5, 10, 20)

6 Fluid Cleanliness Rating

Code	Target fluid cleanliness level
03	16/14/12 or better
05	18/16/14 or better
10	20/18/15 or better
20	22/19/16 or better

Housing Dimensions

mm (inch)

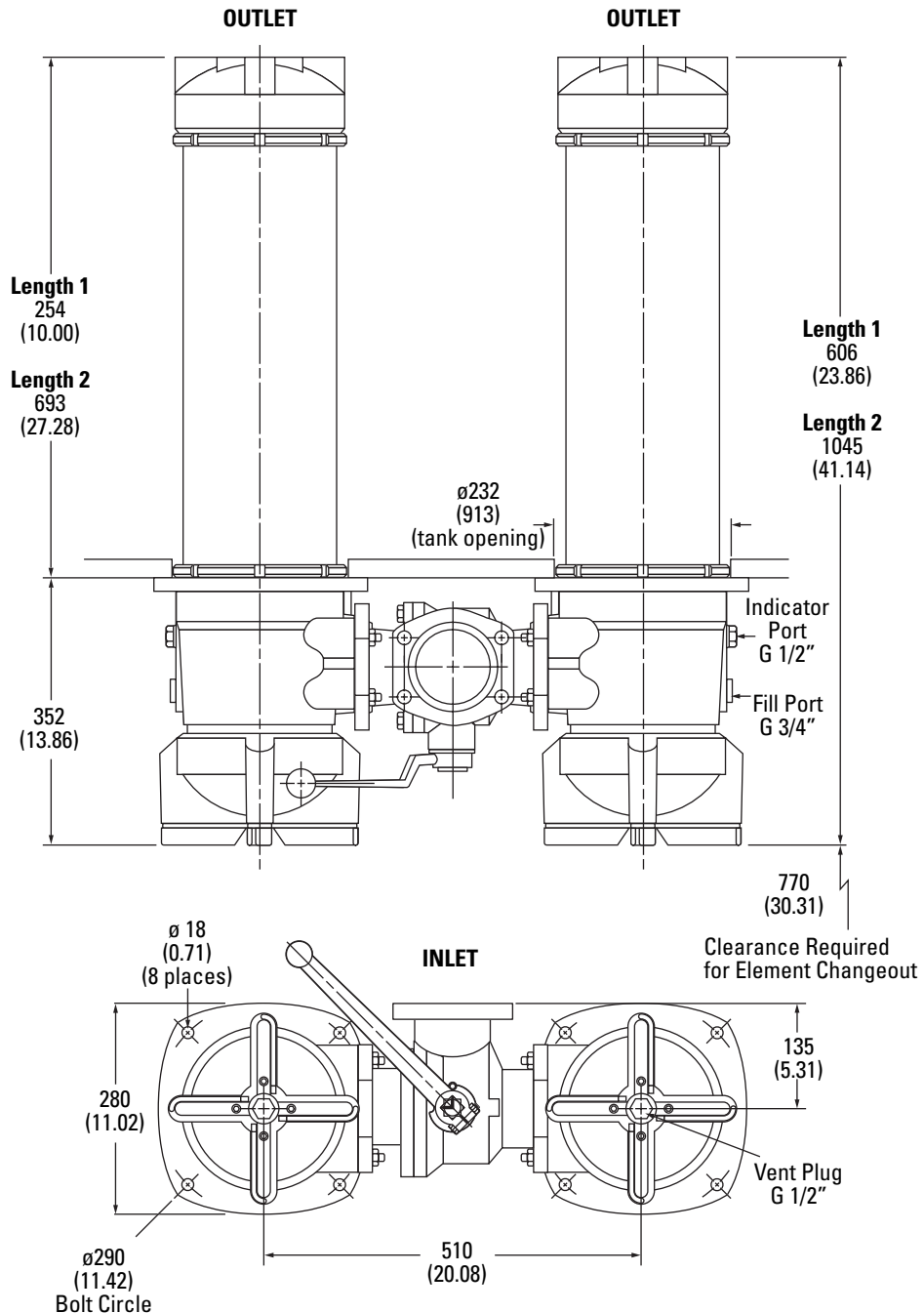

Items not in bold are non-standard and may have a longer lead time

Return Line Filters

HV6RD Series

Flow Data

Flows to 1700 L/min (450 USgpm)
Pressures to 25 bar (360 PSI)

Flow versus pressure drop:

150 SUS (32 cSt) oil with specific gravity of ≤ 0.9

Element Flow Data

HV6RD C-Pack Length 1

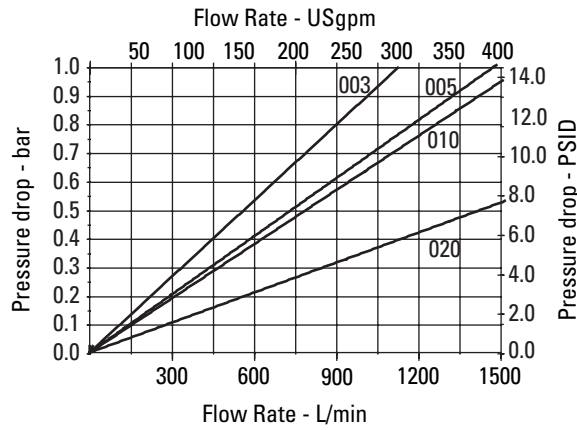

HV6RD C-Pack Length 2

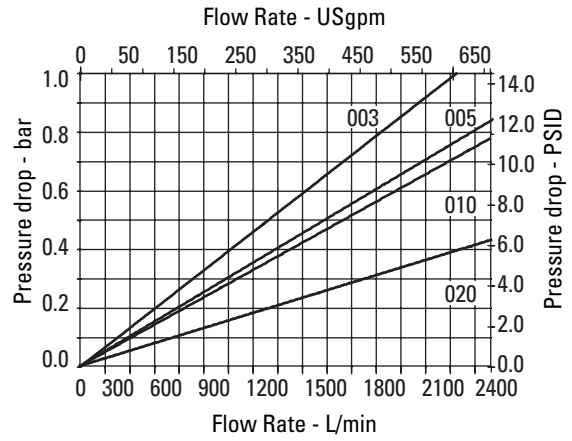

Housing/Bypass Valve Flow Data

Housing

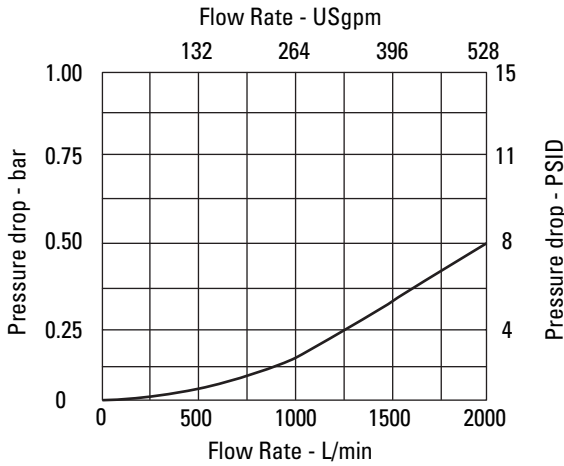

Bypass Valve

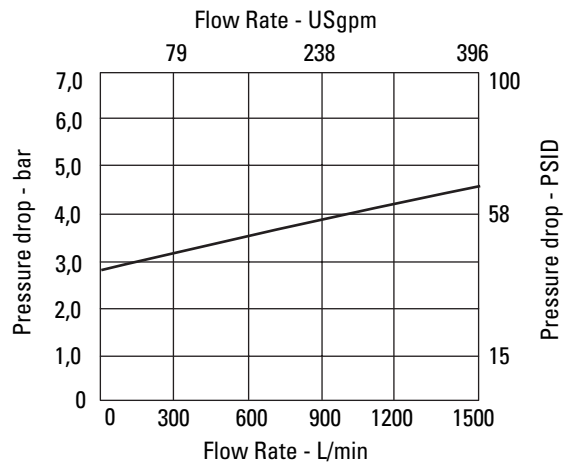

Return Line Filters

HF4RT Series

Flows to 454 L/min (120 USgpm)
Pressures to 7 bar (100 PSI)



Features and Benefits

- Designed to comply with ANSI specifications and ISO cleanliness standards.
- Conforms to HF4 specifications
- Gauge and electrical switch options available to monitor element loading
- In-tank configuration minimizes space requirements and potential system leakage points.
- Optional secondary port allows filtration of a second return line without additional fittings or filtered fill port.
- High efficiency replacement elements in standard configurations (C-Pak) to meet Target Cleanliness Levels. Optional extend tube allows smaller filtration unit to be used where needed

DESIGN SPECIFICATIONS

Rated flow:	Length 3	189 L/min (50 USgpm)
	Length 6	379 L/min (100 USgpm)
	Length 7	454 L/min (120 USgpm)
Fluid compatibility:	Compatible with most petroleum oil, oil-in-water and water-in-oil fluids Optional seals available for phosphate esters.	
Temp range:	-30°C to 121°C (-22°F to 250°F)	
Pressure rating:	Operating	7 bar (100 PSI)
	Fatigue	7 bar (100 PSI)
Material:	Head	Aluminum
	Cover	Aluminum
	Bowl	Carbon Steel
Dry weight: (Approximate)	Length 3	4,5 kg. (10.0 lbs.)
	Length 6	6,6 kg. (14.5 lbs.)
	Length 7	8,4 kg. (18.6 lbs.)

HF4RT Series Filter and Element Model Code

Sample model code:

HF4RT1SD313NBC05

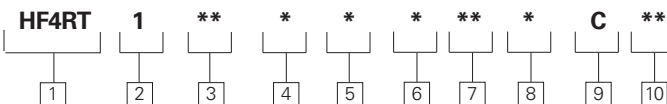

1 Filter Series - HF4RT

2 Element Collapse Rating

1 - 150 PSI Low Collapse

3 Port Options

BC - G1¹/₄ to ISO 228
ME - 1¹/₂" - SAE 4 bolt Flange
Code 61 (M12 x 1.75)

SD - 1.875 - 12 UN SAE-24
str. Thd. (1¹/₂" tube)

FE - 1¹/₂" - SAE 4 bolt Flange
Code 61 (UNC)

4 Valve Options

3 - Bypass set at 25 PSI
cracking pressure

4 - Bypass set at 43 PSI
cracking pressure

5 Indicator Options

1 - No indicator

2 - Gauge 0-4 Bar (0-60 psi)
Use with valve option "4"

4 - Gauge 0-10 Bar (0-160 psi)
Use with valve option "3"

6 - Electrical switch, 15 PSI
Brad Harrison connector

7 - Electrical switch, 30 PSI
Brad Harrison connector

8 - Electrical switch, 15 PSI
Hirshman connector

9 - Electrical switch, 30 PSI
Hirshman connector

6 Assembly Length

mm (inch)

3 - 378 (14.9)

6 - 584 (23)

7 - 787 (31)

9 - 12" extend tube and
Length 3 Filter

7 Secondary Port

BC - G1¹/₄ to ISO 228 - use
with BC Inlet Port

SD - 1.875 - 12 UN SAE-24
str. Thd. (1¹/₂" tube) -

use with SD Inlet Port

SZ -2.50 - 12 UN SAE-32 str.
Thd. (2" tube) - use with

FE Inlet Port

N - No Secondary Port

Note: No secondary port is available with the

ME inlet port option.

8 Seal Material

B - Buna-N

V - Viton-A

9 Element Construction

C - Standard Construction

10 Fluid Cleanliness Rating Target fluid

Code	cleanliness level
03	16/14/12 or better
05	18/16/14 or better
10	20/18/15 or better
20	22/19/16 or better

Items not in bold are non-standard and may have a longer lead time

Return Line Filters

HF4RT Series

Flows to 280 L/min (75 USgpm)
Pressures to 50 bar (725 PSI)

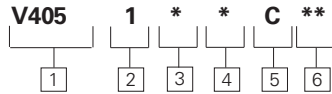

V405 Element Model Code

Sample model code:
V4051B3C05

1 Filter Element

V405 - For use with HF4RT, HF4P & OFR60

2 Element Collapse Rating

1 - 150 PSI Low Collapse

3 Seal Material

B - Buna-N
V - Viton-A

4 Element Length

mm (inch)
3 - 229 (9)
6 - 457 (18)
7 - 686 (27)

5 Element Construction

C - C-Pak (grade 3, 5, 10, 20)

6 Fluid Cleanliness Rating

Code	Target fluid cleanliness level
03	16/14/12 or better
05	18/16/14 or better
10	20/18/15 or better
20	22/19/16 or better

Housing Dimensions

mm (inch)

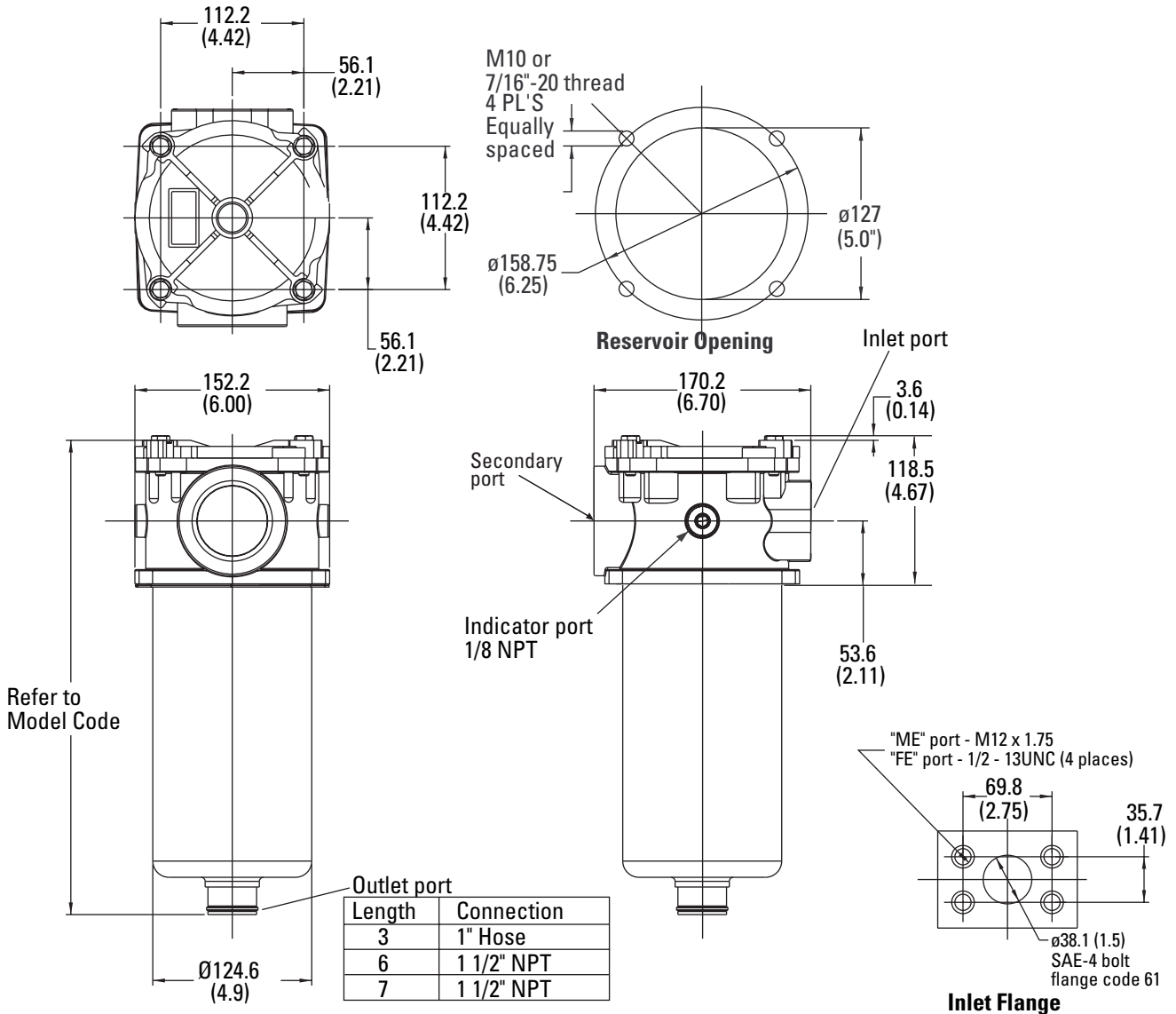

Items not in bold are non-standard and may have a longer lead time

Return Line Filters

HF4RT Series

Flow Data

Flows to 280 L/min (75 USgpm)
Pressures to 50 bar (725 PSI)

Flow versus pressure drop:

150 SUS (32 cSt) oil with specific gravity of ≤ 0.9

Element Flow Data

HF4RT C-Pak Length 3

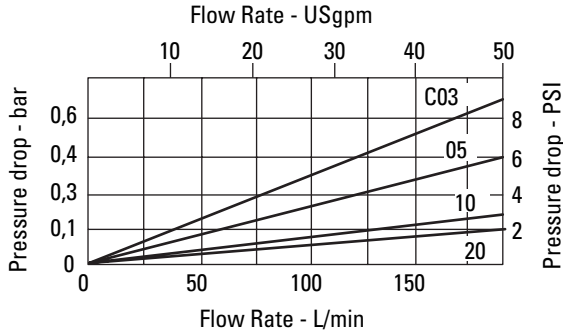

HF4RT C-Pak Length 6

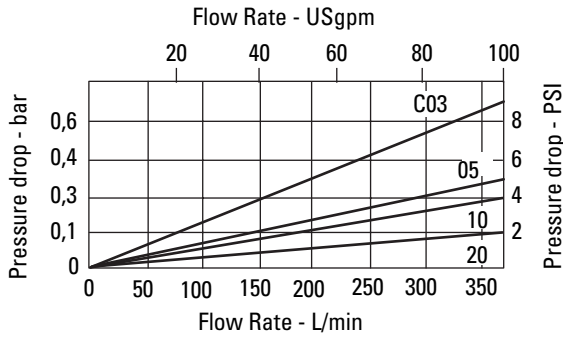

HF4RT C-Pak Length 7

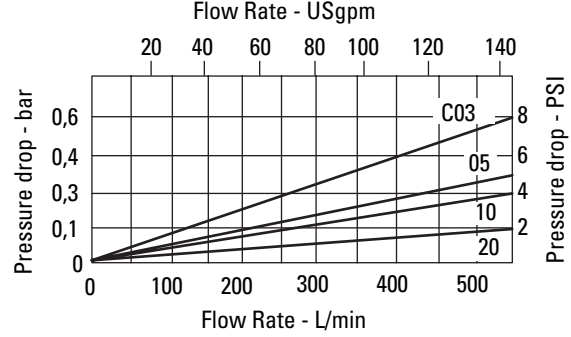

Housing/Bypass Valve Flow Data

Housing

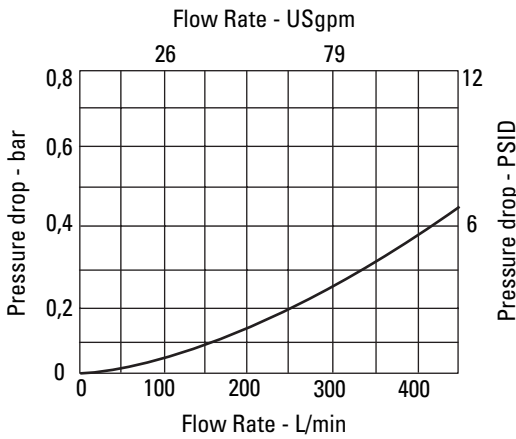

Bypass Valve

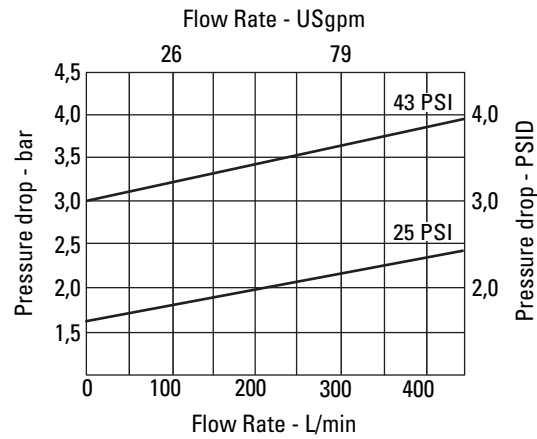

Pressure Filters

OFR30 Series

Flows to 115 L/min (30 USgpm)
Pressures to 40 bar (600 PSI)



Features and Benefits

- OFR-30 conforms to HF3 specifications.
- Flows to 30 USgpm.
- Visual indicator is standard.
- Electrical indicator also available.
- Bypass valve is standard.
- Replacement elements available in C-Pak.

DESIGN SPECIFICATIONS

Rated flow:	115 L/min (30 US gpm)	
Fluid compatibility:	Compatible with most petroleum oil, oil-in-water and water-in-oil fluids.	
Temp range:	-40°C to +107°C (- 40°F to +225°F)	
Pressure rating:	Operating	40 bar (600 PSI)
Bypass setting:	25 PSI	
Material:	Head Bowl	Die cast aluminum Carbon steel
Dry weight: (Approximate)	5,4 kg (12lbs)	

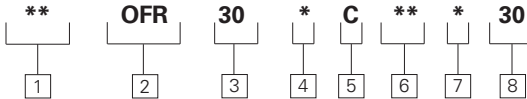

OFR30 Series Filter and Element Model Code

Sample model code:
F3OFR30S03E30S50

1 Seals

Blank - Buna-N
F3 - Viton-A

2 Filter Series - OFR

3 Flow Capacity

30 - 115 L/min (30 USgpm)

4 Port Options

B - G1 (formerly 1" BSPF) thread
F - 1" SAE 4-bolt flange Code 61
S - 1.3125-12 UN SAE-16 straight thread 1" O.D. tube

5 Element Construction

C - C-Pak (grade 3, 5 10, 20)

6 Fluid Cleanliness Rating

Code	Target fluid cleanliness level
03	16/14/12
05	18/16/14
10	20/18/15
20	22/19/16

7 Delta Indicator Options

Blank - Mechanical 25 PSI
E - Electrical 25 PSI

8 Design

30 -Standard Design

Pressure Filters

OFR30 Series

Flows to 115 L/min (30 USgpm)
Pressures to 40 bar (600 PSI)

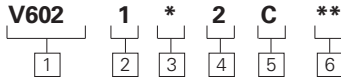

V602 Element Model Codes

(Meets HF3 Specifications)

Sample model code:

V6021B2C03

1 Filter Element -V602

2 Element Collapse Rating

1 - 150 PSI Low Collapse

3 Seals

B - Buna-N

V - Viton-A

4 Element Length

mm (inch)

2 - 203 (8) (HF3 length)

5 Element Construction

C - C-Pak (grade 3, 5, 10, 20)

6 Fluid Cleanliness Ratings

Code	Target fluid cleanliness level
03	16/14/12
05	18/16/14
10	20/18/15
20	22/19/16

Housing Dimensions

Mechanical Indicator

mm (inch)

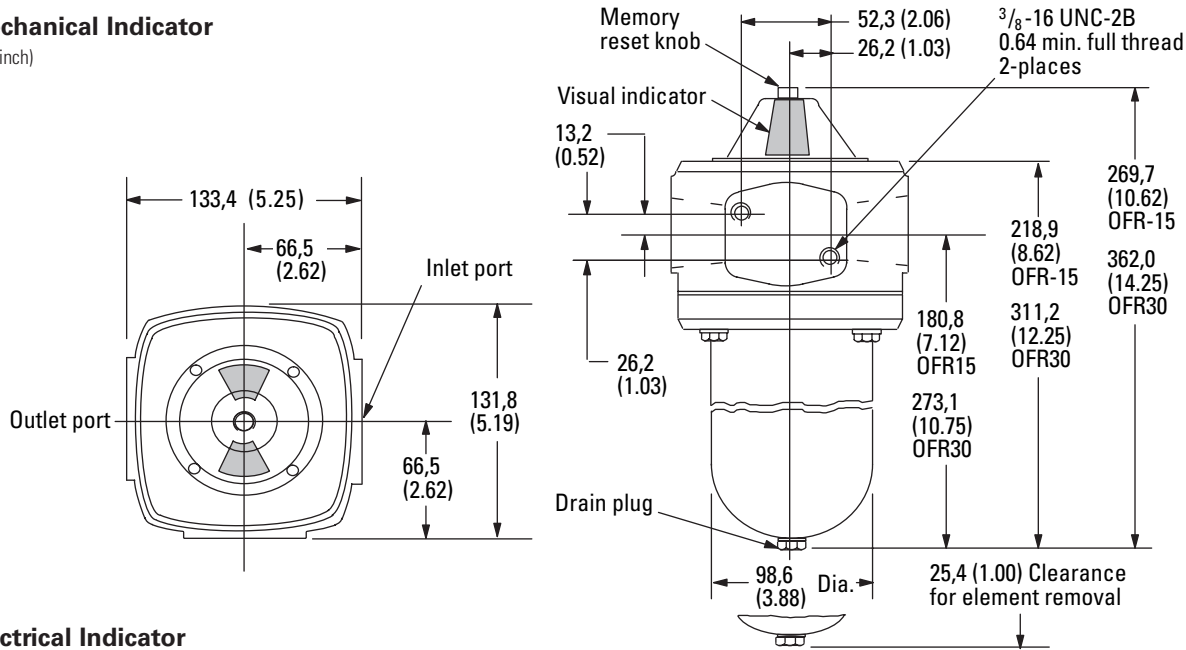

Electrical Indicator

mm (inch)

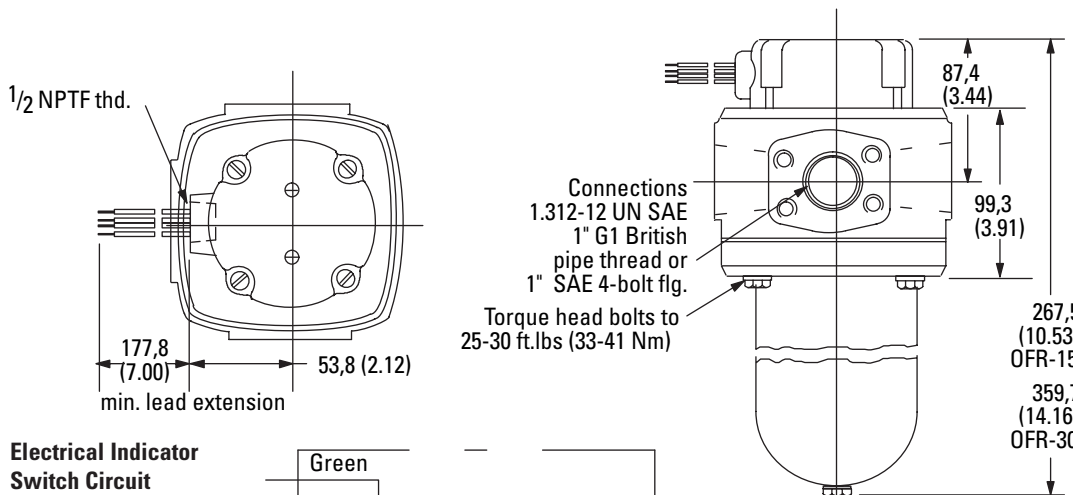

Electrical Indicator Switch Circuit

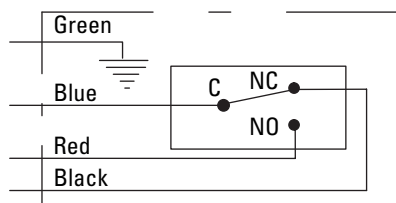

Items not in bold are non-standard and may have a longer lead time

Pressure Filters

Flows to 115 L/min (30 USgpm)
Pressures to 40 bar (600 PSI)

OFR 30 Series

Flow Data

Flow versus pressure drop:

150 SUS (32 cSt) oil with specific gravity of ≤ 0.9

Element Flow Data

OFR30 C-Pak

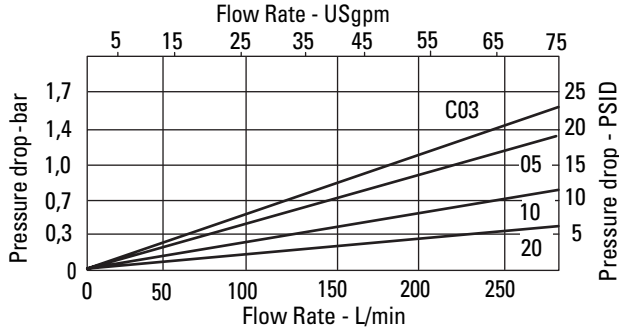

Housing/Bypass Valve Flow Data

Housing

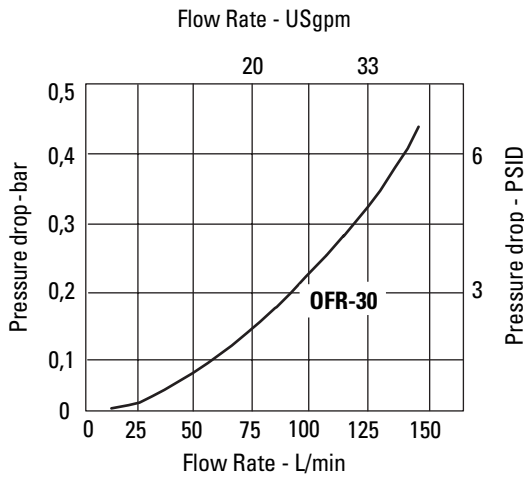

Bypass Valve

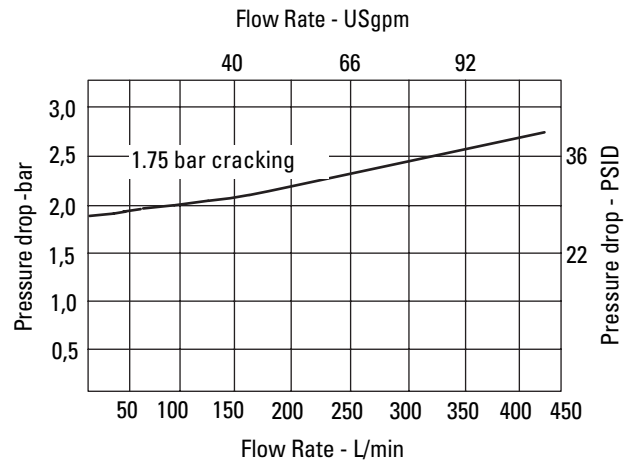

Pressure Filters

OFR 60/120 Series

Flows to 450 L/min (120 USgpm)
Pressures to 27 bar (400 PSI)



Features and Benefits

- Visual indicator is standard.
- Electrical indicator also available.
- Bypass valve is standard.
- Replacement elements available in C-Pak.

DESIGN SPECIFICATIONS

Rated flow:	OFR60 OFR120	225 L/min (60 USgpm) 450 L/min (120 USgpm)
Fluid compatibility:	Compatible with most petroleum oil, water glycol, oil-in-water and water-in-oil fluids.	
Temp range:	-40°C to +107°C (-40°F to +225°F)	
Pressure rating:	Operating	27 bar (400 PSI)
Material:	Head Bowl	Die cast aluminum Carbon steel
Dry weight: (Approximate)	OFR60 OFR120	6,8 kg (15 lbs) 9,5 kg (21 lbs)

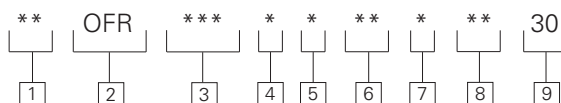

OFR 60/120 Series Filter and Element Model Code

Sample model code:
F3OFR60S03E3530

1 Seals

Blank - Buna-N
F3 - Viton-A

2 Filter Type

OFR - Oil filter return line

3 Flow Capacity

60 - 227 L/min (60 USgpm)
120 - 454 L/min (120 USgpm)

4 Port Options

F - 1½" SAE 4-bolt flange
Code 61
S - 1.875-12 UN SAE-24
straight thread for 1½"
O.D. tube

5 Element Construction

C - C-Pak (grade 3, 5 10, 20)

6 Fluid cleanliness rating

Code	Target fluid cleanliness level
03	16/14/12
05	18/16/14
10	20/18/15
20	22/19/16

7 P Indicator Options

Blank - Mechanical
E - Electrical

8 Bypass Setting

Blank - Bypass set at 25 PSI
Standard cracking pressure
35 - Bypass set at 35 PSI
cracking pressure
50 - Bypass set at 50 PSI
cracking pressure

** **CAUTION**

Applications involving high flow surges may cause element collapse due to instantaneous pressure spikes.

9 Design

30 - Standard Design

Items not in bold are non-standard and may have a longer lead time

Pressure Filters

Flows to 450 L/min (120 USgpm)
Pressures to 27 bar (400 PSI)

OFR 60/120 Series

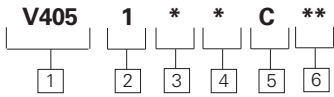

V405 Element Model Code

(Meets HF4 Standard)

Sample model code:

V4051B3C03

1 Filter Element - V405

2 Element Collapse Rating

1 - 150 PSI

3 Seals

B - Buna-N

V - Viton-A

4 Element Length

mm (inch)

3 - 229 (9) (Use in OFR-60)*

6 - 457 (18) (Use in OFR-120)

5 Element Construction

C - C-Pak (grade 3, 5, 10, 20)

6 Fluid Cleanliness Rating

Code	Target fluid cleanliness level
03	16/14/12
05	18/16/14
10	20/18/15
20	22/19/16

*NOTE: Two 9 inch elements and a P-227567-01 reusable connector can also be used in the OFR-120 housing. This arrangement meets HF4 specifications.

Housing Dimensions

Mechanical Indicator

mm (inch)

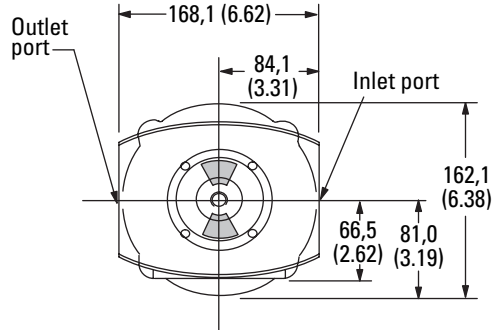

Note

Plastic plug, part number 737365, is installed in the filter element to close the end of the element. When servicing element, remove and retain plastic plug 737365. Install new element with plastic plug on bottom.

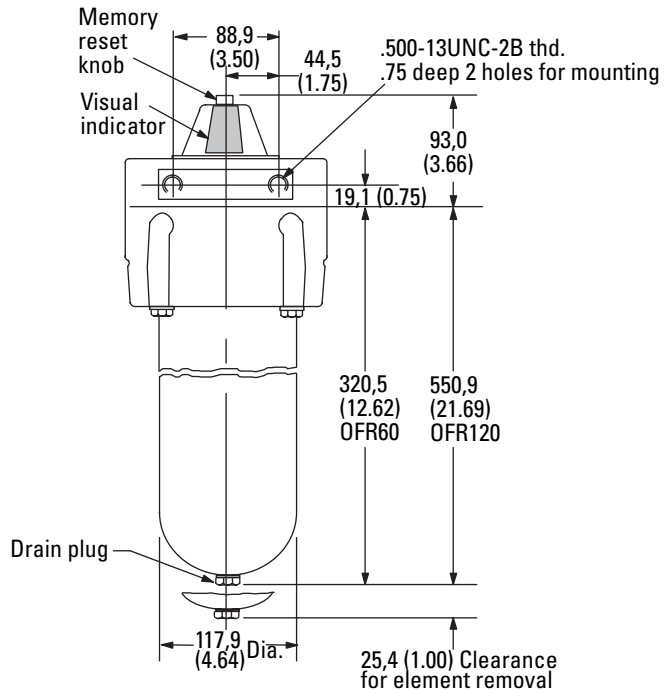

Electrical Indicator

mm (inch)

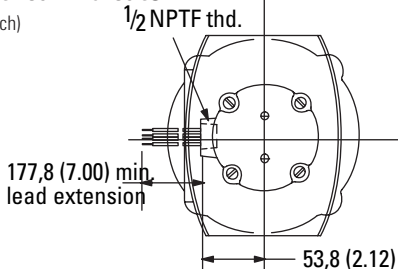

Electrical Indicator Switch Circuit

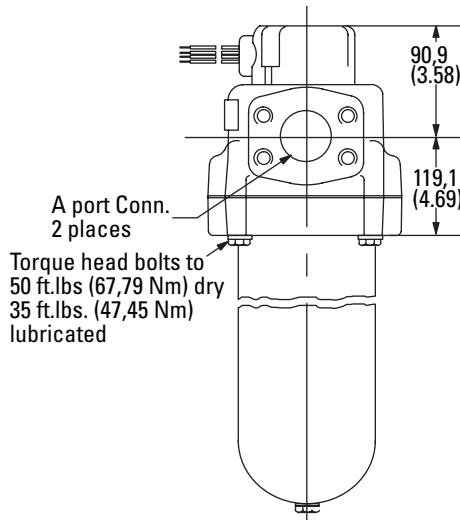
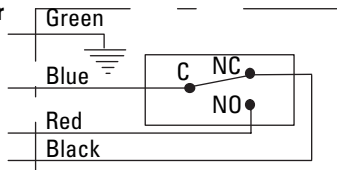

Pressure Filters

Flows to 450 L/min (120 USgpm)
Pressures to 27 bar (400 PSI)

OFR 60/120 Series

Flow versus pressure drop:

150 SUS (32 cSt) oil with specific gravity of ≤ 0.9

Flow Data

Element Flow Data

OFR60 C-Pak Element

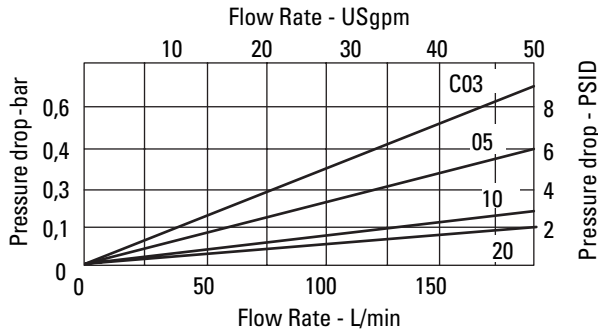

OFR120 C-Pak Element

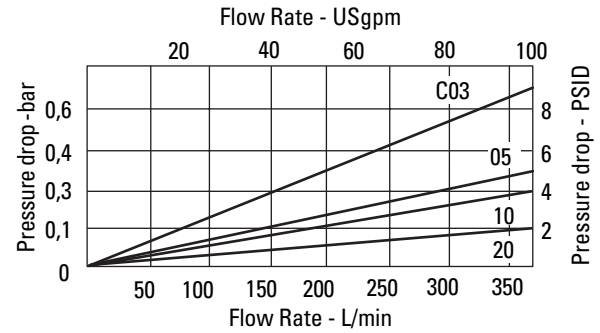

Housing/Bypass Valve Flow Data

Housing

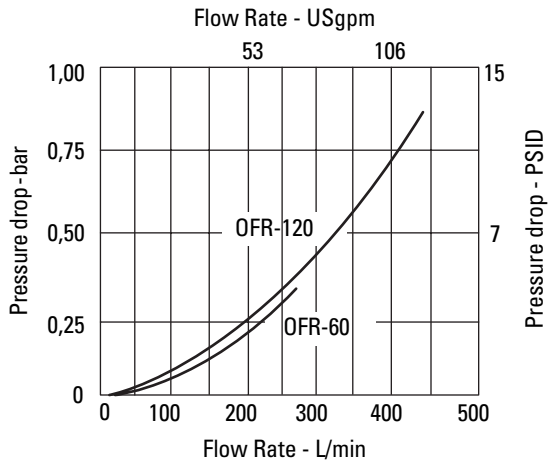

Bypass Valve

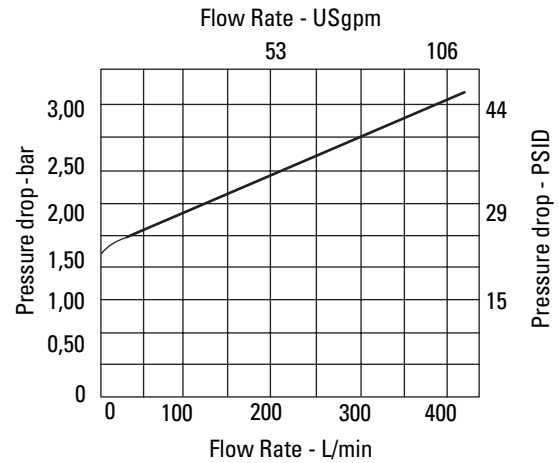

Pressure Filters

DLR DIN Series Filters

Flows to 400 L/min (106 USgpm)
Pressures to 25 bar (363 PSI)



Features and Benefits

- Visual, electrical, and electrical indicators with light options for system design flexibility
- Fully serviceable without tools
- Zero leak by-pass valve construction.
- Wide range of element lengths for maximum design flexibility
- High efficiency replacement elements in standard configurations (C-Pak) to meet Target Cleanliness Levels

DESIGN SPECIFICATIONS

Rated flow:	160 250 400	160 L/min (42.2 USgpm) 250 L/min (66.0 USgpm) 400 L/min (105.7 USgpm)
Fluid compatibility:	Compatible with most petroleum oil, oil-in-water and water-in-oil fluids. Optional seals available for phosphate esters	
Temp range:	-30°C to +100°C (-22°F to +212°F)	
Pressure rating:	Operating	25 bar (363 PSI)
Material:	Aluminum	
Dry weight:	160 250 400	4,3 kg (9.5 lbs) 4,9 kg (10.8 lbs) 5,9 kg (13.0 lbs)

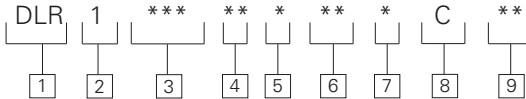

DLR Series Filter

Sample model code:

DLR1160BE1JNBC05

1 Filter Series

DLR - DIN Low Pressure Return

2 Element Collapse Rating

1 - Low Collapse

3 Nominal Size

160 - 160L/min (42.2USgpm)
250 - 250L/min (66.0USgpm)
400 - 400L/min (105.7USgpm)

4 Port Size

BE - G 1 1/4" (Length 160 only)
BF - G 1 1/2" (Length 250 only)
BF - DN 38, Flange SAE 1 1/2", 3000 PSI (Length 400 only)

5 Valve Options

1 - Non-Bypass
6 - 7 Bar

6 Indicator Options

AN - Visual 70 PSI, No Connector
JN - No Indicator, No Connector
TH - Electrical 70 PSI, Hirschman

7 Seal Material

B - Buna-N
V - Viton-A

8 Element Construction

C - Standard Construction

9 Fluid Cleanliness Rating

Code	Target fluid cleanliness level
03	16/14/12 or better
06	18/16/14 or better
10	20/18/15 or better
25	22/19/16 or better

Pressure Filters

DLR DIN Series Filters

Flows to 400 L/min (106 USgpm)
Pressures to 25 bar (363 PSI)

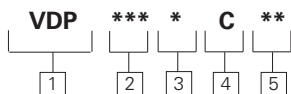

Element model code

Sample model code:

VDP160BC06

1 Filter Element
VDP - DIN Standard Element

2 Nominal Size
160 - 160L/min (42.2USgpm)
250 - 250L/min (66.0USgpm)
400 - 400L/min (105.7USgpm)

3 Seal Material
B - Buna-N
V - Viton-A

4 Element Construction
C - Standard Construction

5 Fluid Cleanliness Rating
Code **Target fluid cleanliness level**

03	16/14/12 or better
06	18/16/14 or better
10	20/18/15 or better
25	22/19/16 or better

DLR Housing

Dimensions in mm

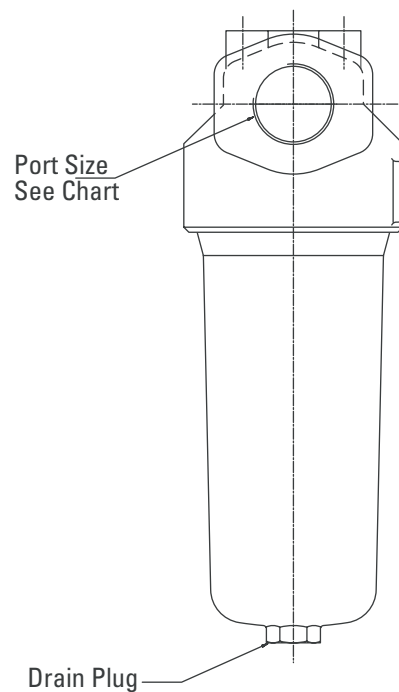
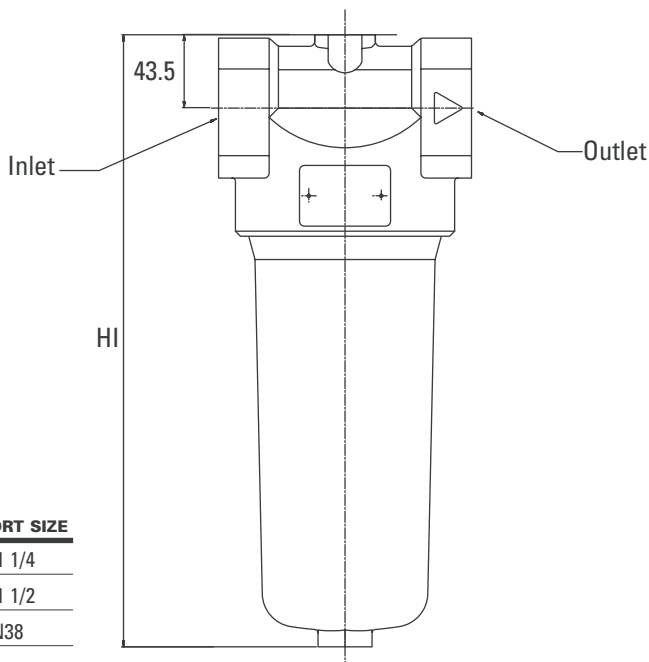

TYPE	HI	PORT SIZE
DLR 160	285	G 1 1/4
DLR 250	363	G 1 1/2
DLR 400	513	DN38

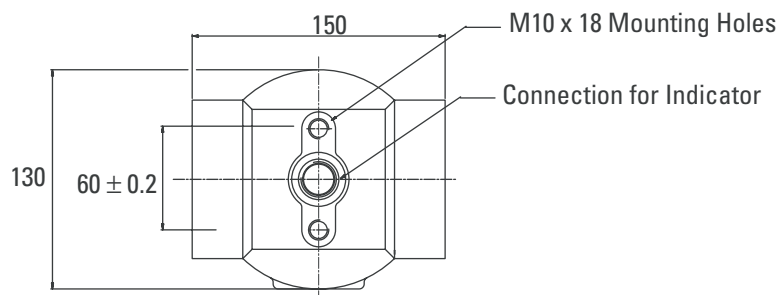

Items not in bold are non-standard and may have a longer lead time

Pressure Filters

DLR DIN Series Filters

Flows to 400 L/min (106 USgpm)
Pressures to 25 bar (363 PSI)

Element Flow Data

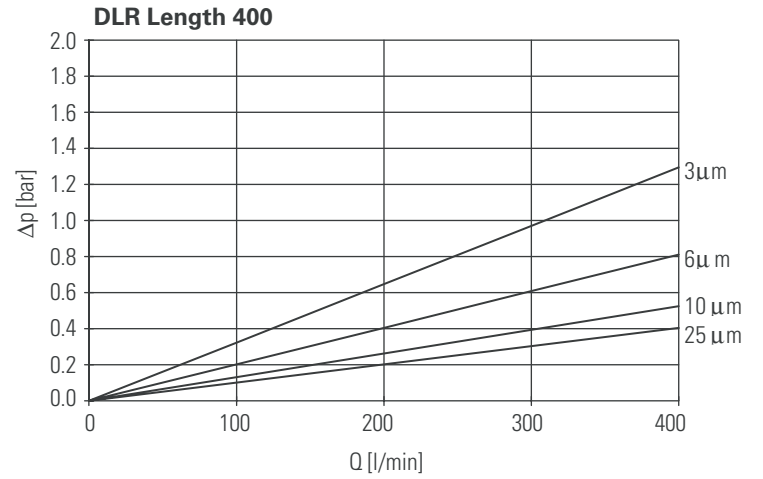
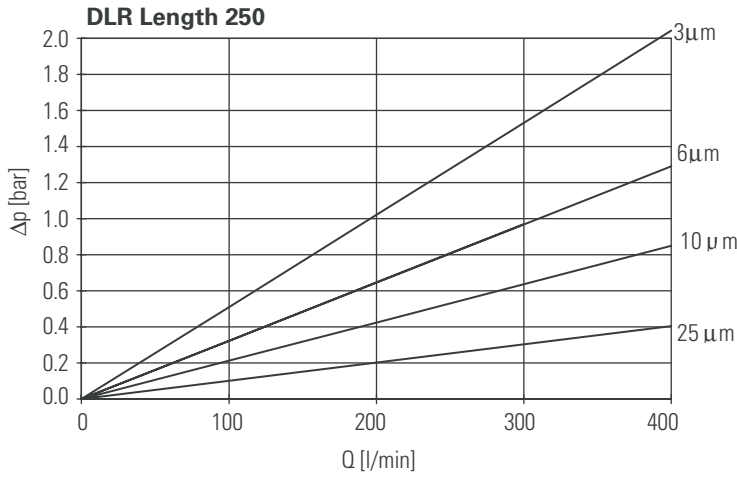
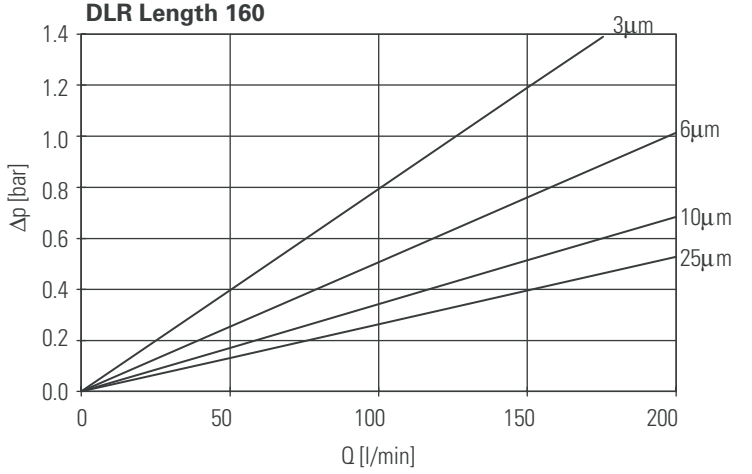

Pressure Filters

LND

Flows to 400 L/min (105 USgpm)
Pressures to 25 bar (360 PSI)



Features and Benefits

- Lightweight duplex filter constructed of aluminum.
- Aluminum alloy is water tolerant - anodization is not required for high water based fluids (HWBF).
- The screw-in bowl allows the filter element to be easily removed for replacement or cleaning.
- The standard model is supplied with vent and drain plugs, and also a connection for differential clogging indicator.

DESIGN SPECIFICATIONS

Rated flow:	Length 1	160 L/min (42 USgpm)
	Length 2	250 L/min (66 USgpm)
	Length 4	400 L/min (105 USgpm)
Fluid compatibility:	Compatible with all petroleum oils and synthetic fluids rated for use with Fluoro-Rubber or Ethylene Propylene seals.	
Temp range:	-30°C to + 121°C (-22°F to 250°F)	
Pressure rating:	Operating	25 bar (360 PSI)
	Fatigue	25 bar (360 PSI)
Material:	Aluminum	
Dry weight: (Approximate)	Length 1	10,3 kg (22.7 lbs)
	Length 2	11,6 kg (25.6 lbs)
	Length 4	13,0 kg (28.7 lbs)

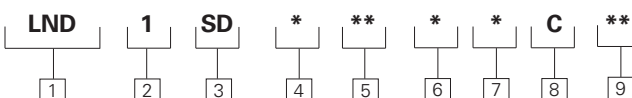

LND Series Filter and Element Model Code

Sample model code:

LND1SD1ANV2C05

1 Filter Series - LND

2 Element Collapse Rating

1 - 250 PSI Low Collapse

3 Port Options

SD - SAE-24 -1-1/2"

4 Valve Options

- 1 - Non-Bypass
- 4 - Bypass set at 43 PSI cracking pressure
- 7 - Bypass set at 102 PSI cracking pressure

5 Indicator Options

- AN - Visual 70 PSI, No Connector
- JN - No Indicator (plug), No Connector
- LN - Visual 30 PSI, No Connector
- RB - Electrical 30 PSI, Brad Harrison
- RH - Electrical 30 PSI, Hirshman

- RJ - Electrical 30 PSI, Hirshman w 24 volt light
- RK - Electrical 30 PSI, Hirshman w 115 volt light
- RL - Electrical 30 PSI, Hirshman w 230 volt light
- UB - Electrical 70 PSI, Brad Harrison
- UH - Electrical 70 PSI, Hirshman
- UJ - Electrical 70 PSI, Hirshman w 24 volt light
- UK - Electrical 70 PSI, Hirshman w 115 volt light
- UL - Electrical 70 PSI, Hirshman w 230 volt light

6 Seal Material

V - Viton-A

7 Assembly Length

- mm (inch)
- 1 - 297 (11.7")
- 2 - 375 (14.8")
- 4 - 525 (20.7")

8 Element Construction

C - Standard Construction

9 Fluid Cleanliness Rating

Code	Target fluid cleanliness level
03	16/14/12 or better
05	18/16/14 or better
10	20/18/15 or better
20	22/19/16 or better

Items not in bold are non-standard and may have a longer lead time

Pressure Filters

LND

Flows to 400 L/min (105 USgpm)
Pressures to 25 bar (360 PSI)

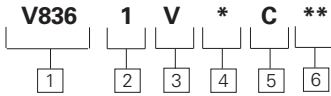

Element model code

Sample model code:

V8361V1C05

1 Filter Element - V836

2 Element Collapse Rating

1 - 250 PSI Low Collapse

3 Seal Material

V - Viton-A

4 Assembly Length

mm (inch)

1 - 297 (11.7)

2 - 375 (14.8)

4 - 525 (20.7)

5 Element Construction

C - Standard Construction

6 Fluid Cleanliness Rating

Code	Target fluid cleanliness level
03	16/14/12 or better
05	18/16/14 or better
10	20/18/15 or better
20	22/19/16 or better

Housing Dimensions

mm (inch)

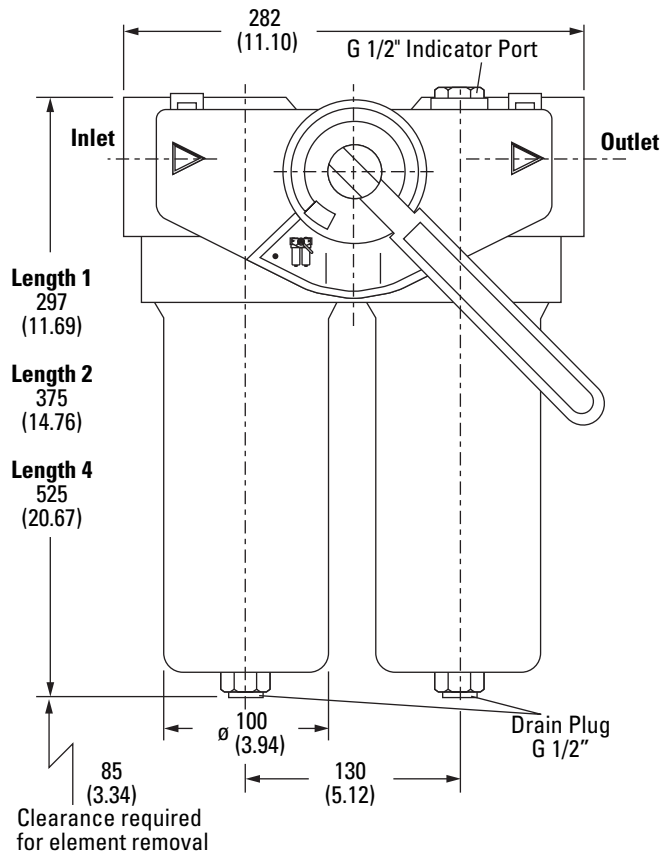
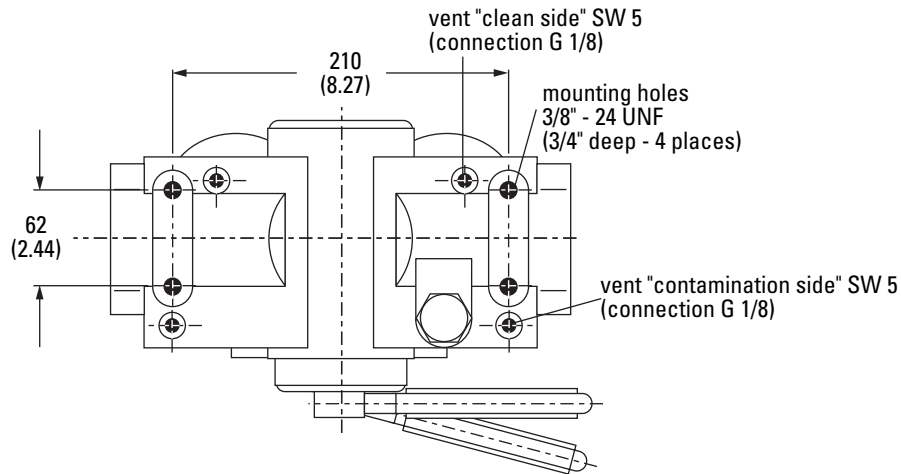

Items not in bold are non-standard and may have a longer lead time

Pressure Filters

Flows to 400 L/min (105 USgpm)
Pressures to 25 bar (360 PSI)

LND

Flow Data

Flow versus pressure drop:

150 SUS (32 cSt) oil with specific gravity of ≤ 0.9

Element Flow Data

LND C-pak Element Length 1

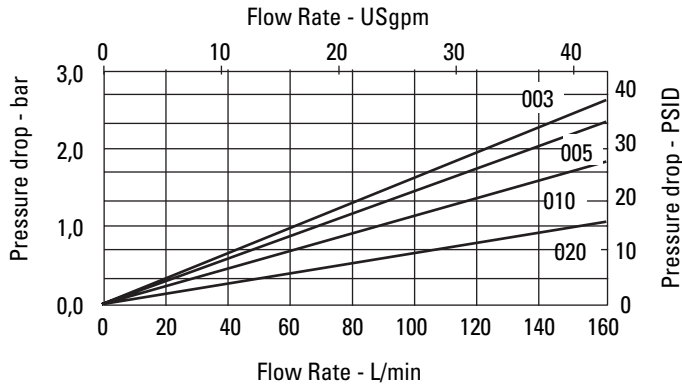

LND C-pak Element Length 2

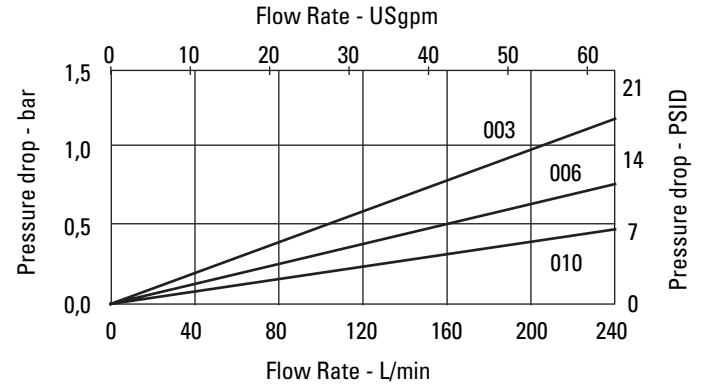

LND C-pak Element Length 4

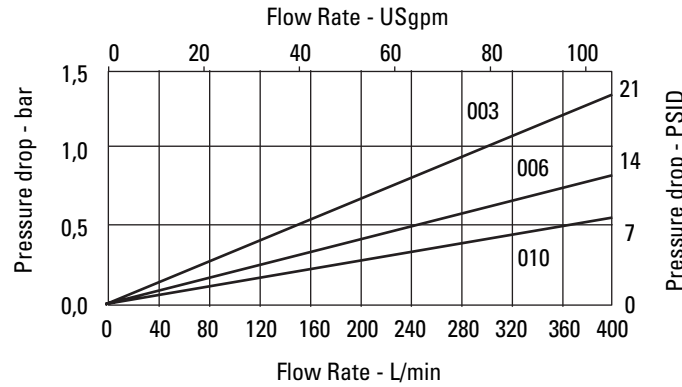

Housing/Bypass Valve Flow Data

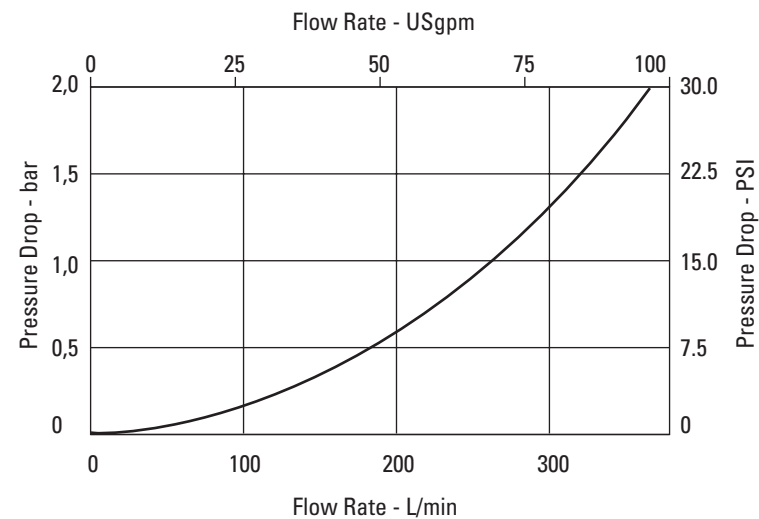

Notes

Items not in bold are non-standard and may have a longer lead time

In-tank Filters

General Data

In-tank filters are a special type of low pressure return line filters. In-tank filters are mounted directly to the reservoir tank top and have an accessible head that is located outside of the reservoir while the body of the housing is located inside the reservoir. The exposed cover allows the element to be easily replaced as needed.

The filter housing may be equipped with diffusers to ensure that the returning oil energy is gradually dissipated within the reservoir fluid to minimize the potential for aerating or foaming of the oil. In addition, the diffuser helps direct the fluid outward against the walls of the reservoir to aid in the heat transfer capability of the reservoir.

Applications

- Forestry harvesting equipment such as delimiters and feller bunchers
- Injection molding or blow molding equipment
- Offshore drilling platform power units
- Machine tools
- Die cast machines



In-tank Filters

OFMT020 Series

Flows to 50 L/min (13.2 USgpm)
Pressures to 7 bar (100 PSI)



Features and Benefits

- High efficiency filter elements with superior dirt-holding capacity designed for return lines and installed semi-immersed in a reservoir.
- Excellent pressure drop characteristics.
- P indicator options for flexibility in system design.
- Bowl length options for design flexibility.
- Easy element changes.
- Bypass valve prevents excessive pressure drop and prevents element collapse and release of retained contaminant's back into hydraulic system.
- Designed to comply with ISO standards

DESIGN SPECIFICATIONS

Rated flow:	Length 1	30 L/min (7.9 USgpm)
	Length 2	35 L/min (9.2 USgpm)
	Length 3	50 L/min (13.2 USgpm)
Fluid compatibility:	Compatible with most petroleum oil, water glycol, oil-in-water and water-in-oil fluids	
Temp range:	-25°C to +110°C (-13°F to +230°F)	
Pressure rating:	Operating	7 bar (100 PSI)
	Fatigue	7 bar (100 PSI)
Material:	Head	Die Cast Aluminum
	Cover	Nylon
	Bowl	Nylon
Dry weight: (Approximate)	Length 1	0,3 kg. (0.66 lbs.)
	Length 2	0,4 kg. (0.88 lbs.)
	Length 3	0,5 kg. (1.10 lbs.)

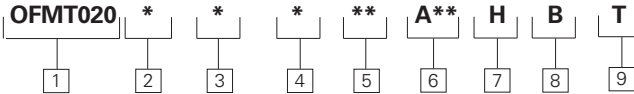

OFMT 020 Series Filter and Element Model Code

Sample model code:
OFMT0201SAG7A06HBT

[1] Filter Series - OFMT020

[2] Assembly Length

mm (inch)

- 1** - 102 (4.0)
- 2** - 165 (6.5)
- 3** - 210 (8.3)

[3] Breather Options

- S** - No breather
- C** - 10 µm breather
- M** - 40 µm breather

[4] Seal Material

- A** - Buna-N
- V** - Viton-A

[5] Port Options

- G1** - 3/8" BSP
- G2** - 1/2" BSP
- G4** - 3/8" NPT
- G5** - 1/2" NPT
- G7** - SAE 6
- G8** - SAE 8

[6] Fluid Cleanliness Rating

Code	cleanliness level
A03	16/14/12 or better
A06	18/16/14 or better
A10	20/18/15 or better

[7] Element Collapse Rating

- H** - 10 bar (150 PSI)

[8] Valve Options

- B** - Bypass set at 25 PSI cracking pressure

[9] Indicator Options

- T** - No Indicator (plug), No Connector

In-tank Filters

OFMT020 Series

Flows to 50 L/min (13.2 USgpm)
Pressures to 7 bar (100 PSI)

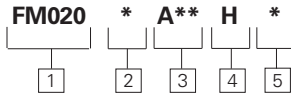

Element model code

Sample model code:

FM0202A06HA

1 Filter Element - FM 020

2 Assembly Length

mm (inch)
1 - 102 (4.0)
2 - 165 (6.5)
3 - 210 (8.3)

3 Fluid Cleanliness Rating

Code	Target fluid cleanliness level
A03	16/14/12 or better
A06	18/16/14 or better
A10	20/18/15 or better

4 Element Collapse Rating

H - 10 bar (150 PSI)

5 Seal Material

A - Buna-N

V - Viton-A

Note: Element comes with bypass set at 25 PSI cracking pressure

Housing Dimensions

mm (inch)

Dimensions in mm (inch)

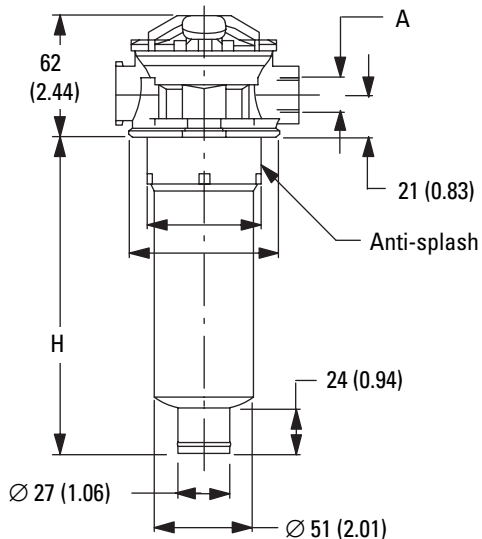
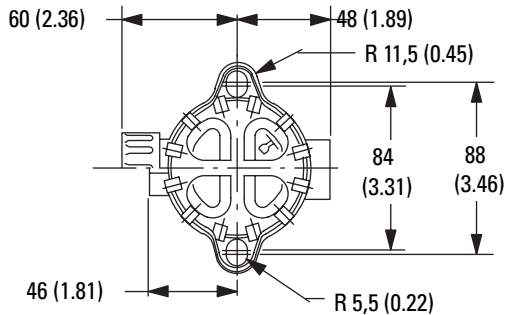

Holes required on tank

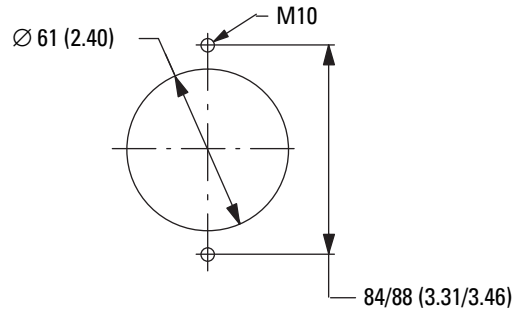

Items not in bold are non-standard and may have a longer lead time

In-tank Filters

OFMT020 Series

Flows to 50 L/min (13.2 USgpm)
Pressures to 7 bar (100 PSI)

Flow Data

Element Flow Data

OFMT020 H-Pak Length 1

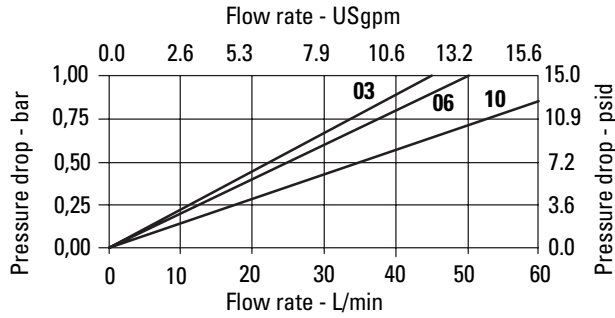

OFMT020 H-Pak Length 2

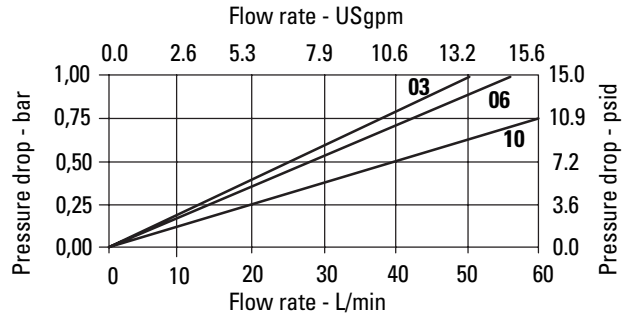

OFMT020 H-Pak Length 3

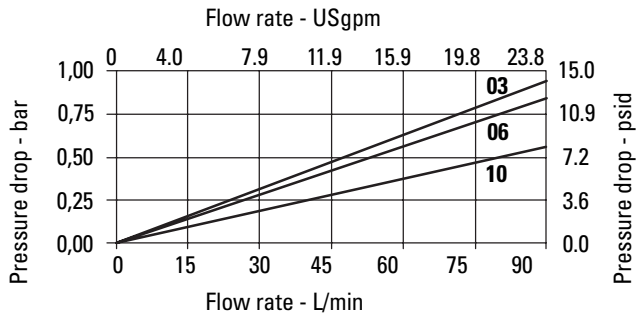

Housing/Bypass Valve Flow Data

Housing

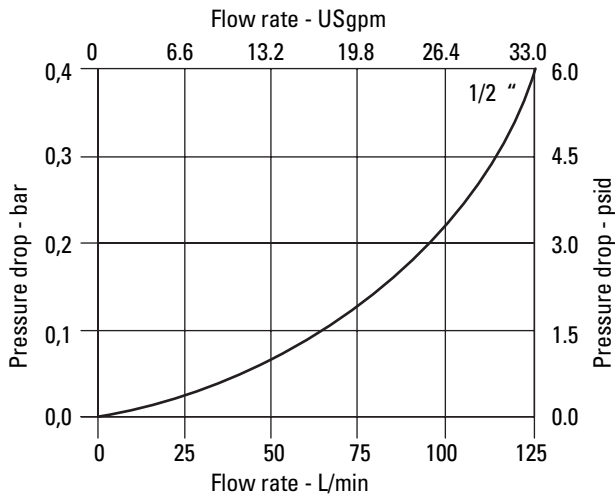

Bypass Valve

Based on mineral oil with density of 0,86 kg/dm³
 ΔP varies proportionally to density.

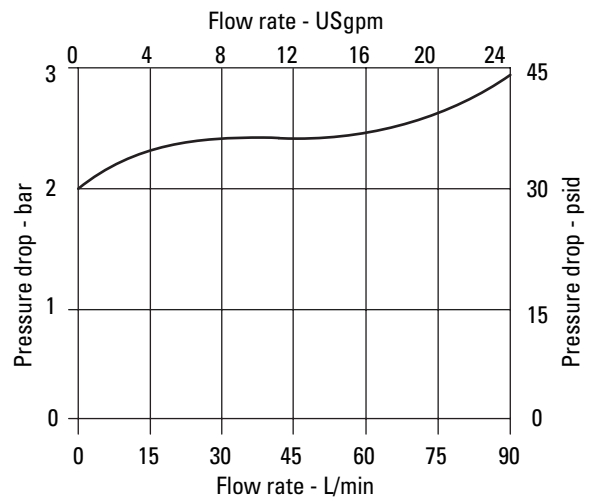

In-tank Filters

OFMT100 Series

Flows to 70 L/min (18.5 USgpm)
Pressures to 7 bar (100 PSI)



Features and Benefits

- High efficiency filter elements with superior dirt-holding capacity designed for return lines and installed semi-immersed in a reservoir.
- Excellent pressure drop characteristics.
- P indicator options for flexibility in system design.
- Bowl length options for design flexibility.
- Easy element changes.
- Bypass valve prevents excessive pressure drop and prevents element collapse and release of retained contaminant's back into hydraulic system.
- Designed to comply with ISO standards

DESIGN SPECIFICATIONS

Rated flow:	Length 1	35 L/min (9.2 USgpm)
	Length 2	45 L/min (11.9 USgpm)
	Length 3	70 L/min (18.5 USgpm)
Fluid compatibility:	Compatible with most petroleum oil, water glycol, oil-in-water and water-in-oil fluids	
Temp range:	-25°C to +110°C (-13°F to +230°F)	
Pressure rating:	Operating	7 bar (100 PSI)
	Fatigue	7 bar (100 PSI)
Material:	Head	Die Cast Aluminum
	Cover and Bowl	Nylon
Dry weight: (Approximate)	Length 1	0,3 kg. (0.66 lbs.)
	Length 2	0,4 kg. (0.88 lbs.)
	Length 3	0,5 kg. (1.10 lbs.)

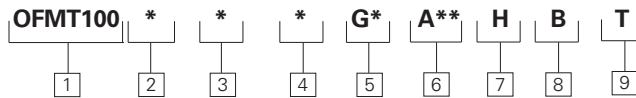

OFMT 100 Series Filter and Element Model Code

Sample model code:
OFMT1001SAG7A06HBT

[1] Filter Series - OFMT 100

[2] Assembly Length

mm (inch)
1 - 102 (4.0)
2 - 145 (5.7)
3 - 225 (8.9)

[3] Breather Options

S - No breather
C - 10 µm breather
M - 40 µm breather

[4] Seal Material

A - Buna-N
V - Viton-A

[5] Port Options

G1 - 3/4" BSP
G2 - 1" BSP
G3 - 1-1/4" BSP
G4 - 3/4" BSP
G5 - 1" NPT
G6 - SAE 12
G7 - SAE 16
G8 - SAE 20

[6] Fluid Cleanliness Rating

Code	cleanliness level
A03	16/14/12 or better
A06	18/16/14 or better
A10	20/18/15 or better

[7] Element Collapse Rating

H - 10 bar (150 PSI)

[8] Valve Options

B - Bypass set at 25 PSI cracking pressure

[9] Indicator Options

T - No Indicator (plug), No Connector

Items not in bold are non-standard and may have a longer lead time

In-tank Filters

OFMT100 Series

Flows to 70 L/min (18.5 USgpm)
Pressures to 7 bar (100 PSI)

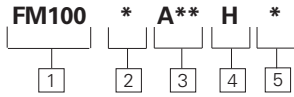

Element model code

1 Filter Element - FM 100

2 Assembly Length

mm (inch)
1 - 102 (4.0)
2 - 145 (5.7)
3 - 225 (8.9)

Sample model code:

FM1002A06HA

3 Fluid Cleanliness Rating

Code	Target fluid cleanliness level
A03	16/14/12 or better
A06	18/16/14 or better
A10	20/18/15 or better

4 Element Collapse Rating

H - 10 bar (150 PSI)

5 Seal Material

A - Buna-N

V - Viton-A

Note: Element comes with bypass set at 25 PSI cracking pressure

Housing Dimensions

mm (inch)

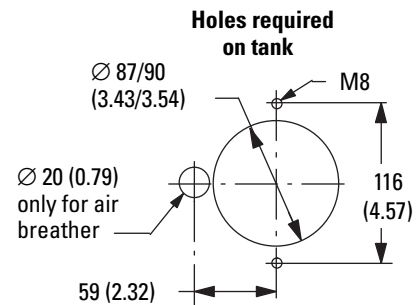
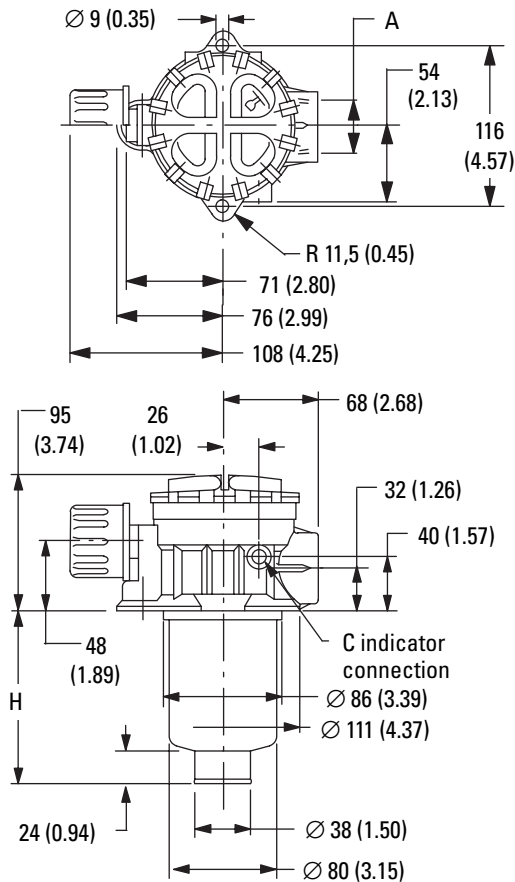

Items not in bold are non-standard and may have a longer lead time

In-tank Filters

OFMT100 Series

Flows to 70 L/min (18.5 USgpm)
Pressures to 7 bar (100 PSI)

Flow Data

Element Flow Data

OFMT100 H-Pak Length 1

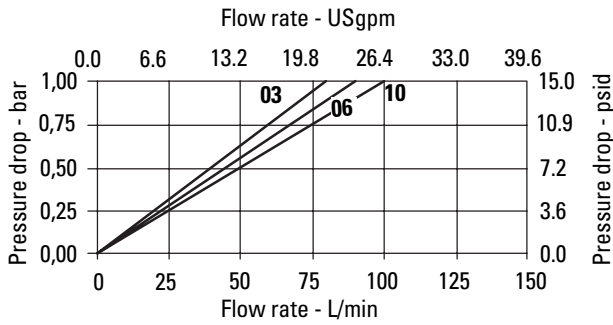

OFMT100 H-Pak Length 2

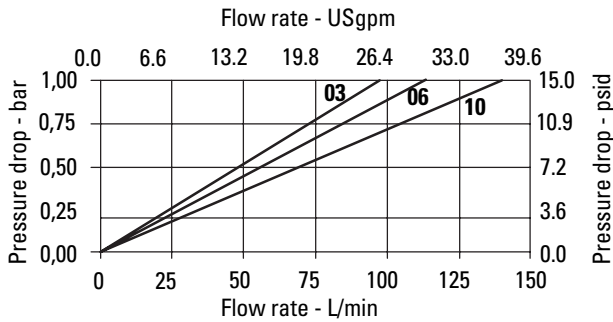

OFMT100 H-Pak Length 3

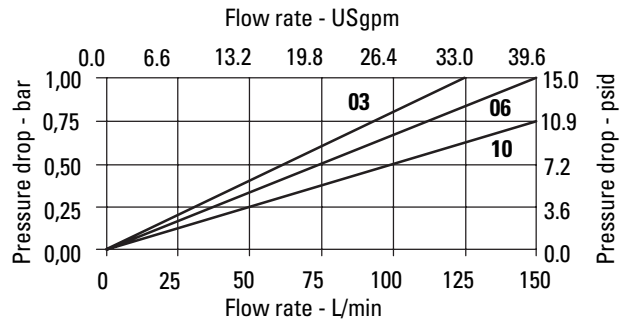

Housing/Bypass Valve Flow Data

Housing

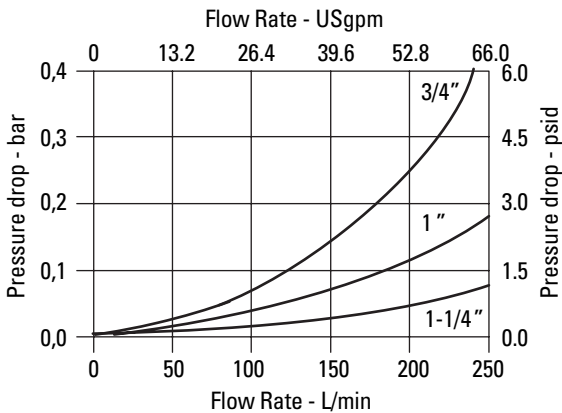

Bypass Valve

Based on mineral oil with density of 0,86 kg/dm³.
ΔP varies proportionally to density.

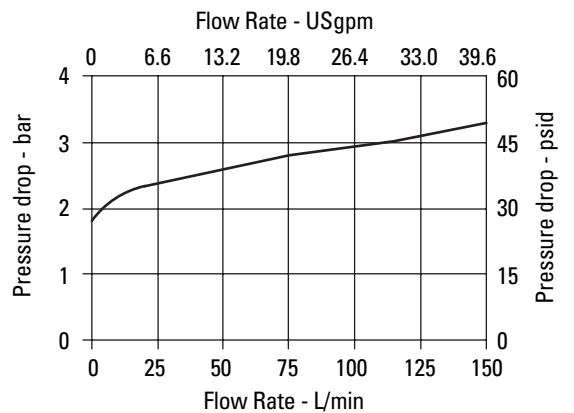

In-tank Filters

OFRT100 Series

Flows to 105 L/min (27.7 USgpm)
Pressures to 10 bar (150 PSI)



Features and Benefits

- High efficiency filter elements with superior dirt-holding capacity designed for return lines and installed semi-immersed in a reservoir.
- Excellent pressure drop characteristics.
- Indicators ordered separately
- Bowl length options for design flexibility.
- Easy element changes.
- Bypass valve prevents excessive pressure drop and prevents element collapse and release of retained contaminant's back into hydraulic system.
- Designed to comply with ISO standards

DESIGN SPECIFICATIONS

Rated flow:	Length 1	35 L/min (9.2 USgpm)
	Length 2	40 L/min (10.6 USgpm)
	Length 3	75 L/min (19.8 USgpm)
	Length 4	105 L/min (27.7 USgpm)
Fluid compatibility:	Compatible with most petroleum oil, water glycol, oil-in-water and water-in-oil fluids, Optional seals available for phosphate esters.	
Temp range:	-25°C to 110°C (-13°F to 230°F)	
Pressure rating:	Operating	10 bar (150 PSI)
	Fatigue	10 bar (150 PSI)
Material:	Head	Die Cast Aluminum
	Cover	Nylon
Dry weight: (Approximate)	Length 1	1,0 kg. (2.20 lbs.)
	Length 2	1,2 kg. (2.63 lbs.)
	Length 3	1,3 kg. (2.87 lbs.)
	Length 4	1,5 kg. (3.31 lbs.)

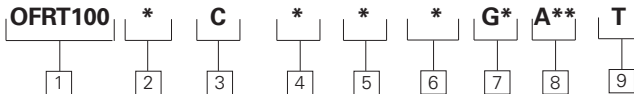

OFRT 100 Series Filter and Element Model Code

Sample model code:

OFRT1001COSAG7A06T

1 Filter Series - OFRT 100

2 Assembly Length

mm (inch)

1 - 225 (8.8)

2 - 269 (10.6)

3 - 319 (12.6)

4 - 419 (16.5)

Length given does not include diffuser

3 Bypass Options

C - Bypass set at 25 PSI cracking pressure

4 Diffuser Options

O - No diffuser

D - With diffuser

5 Breather Options

S - No breather

C - 10 µm breather

M - 40 µm breather

6 Seal Material

A - Buna-N

V - Viton-A

7 Port Options

G1 - 3/4" BSP

G2 - 1" BSP

G3 - 1-1/4" BSP

G4 - 3/4" BSP

G5 - 1" NPT

G6 - 1-1/4" NPT

G7 - SAE 12

G8 - SAE 16

G9 - SAE 20

8 Fluid Cleanliness Rating

Target fluid

Code	cleanliness level
A06	18/16/14 or better
A10	20/18/15 or better

In-tank Filters

OFRT100 Series

Flows to 105 L/min (27.7 USgpm)
Pressures to 10 bar (150 PSI)

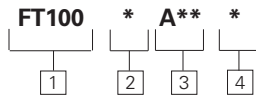

Element model code

Sample model code:

FT1002A06A

1 Filter Element - FT 100

2 Element Length

- mm (inch)
- 1** - 128 (5.0)
 - 2** - 172 (6.8)
 - 3** - 222 (8.7)
 - 4** - 322 (12.7)

3 Fluid Cleanliness Rating

Code	Target fluid cleanliness level
A06	18/16/14 or better
A10	20/18/15 or better

4 Seal Material

A - Buna-N
V - Viton-A

Housing Dimensions

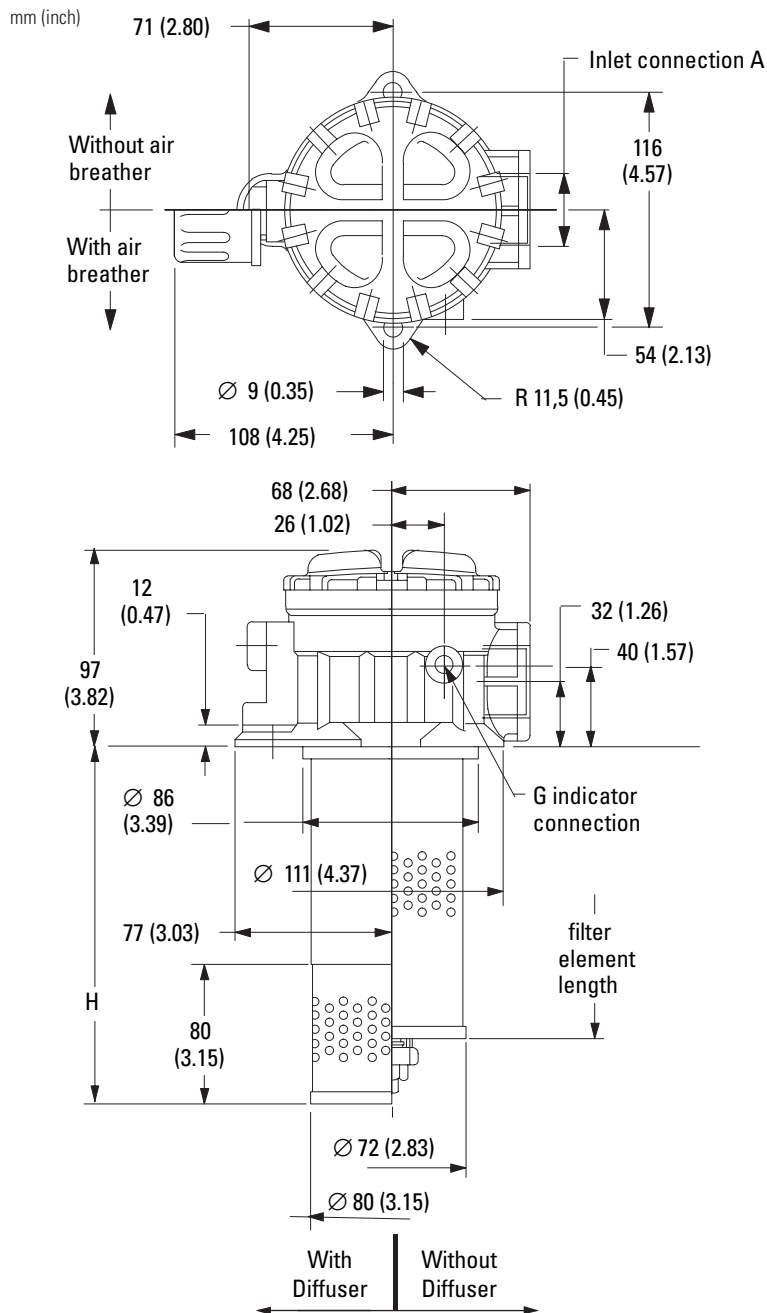

Holes required on tank

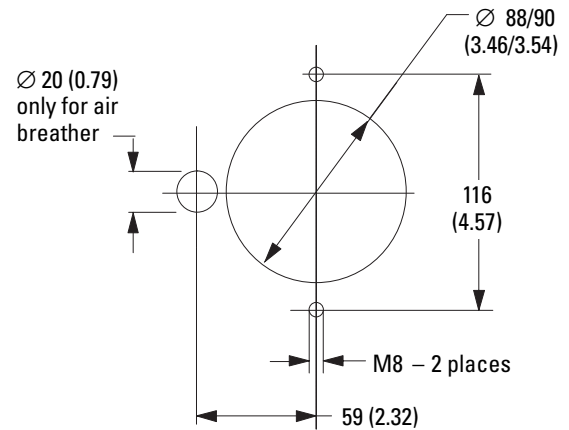

Items not in bold are non-standard and may have a longer lead time

In-tank Filters

OFRT100 Series

Flows to 105 L/min (27.7 USgpm)
Pressures to 10 bar (150 PSI)

Flow Data

Element Flow Data

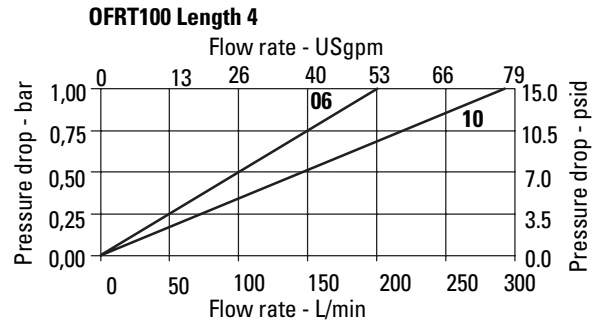
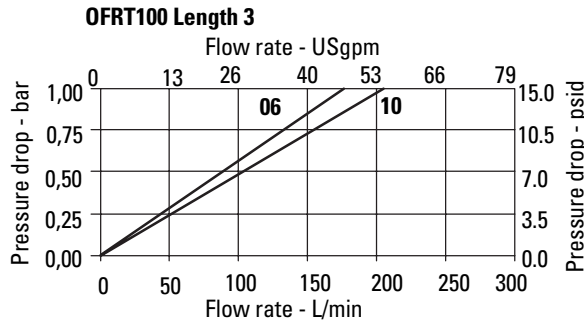
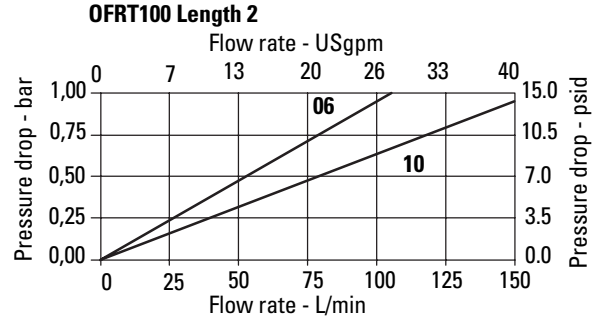
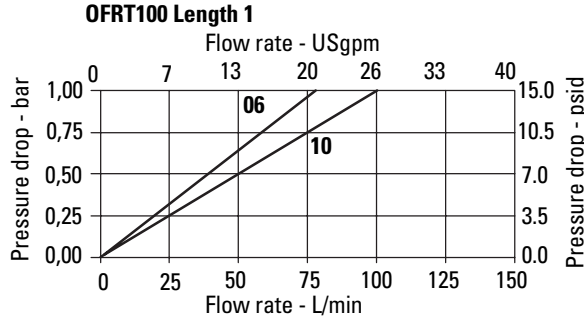

Housing/Bypass Valve Flow Data

Housing

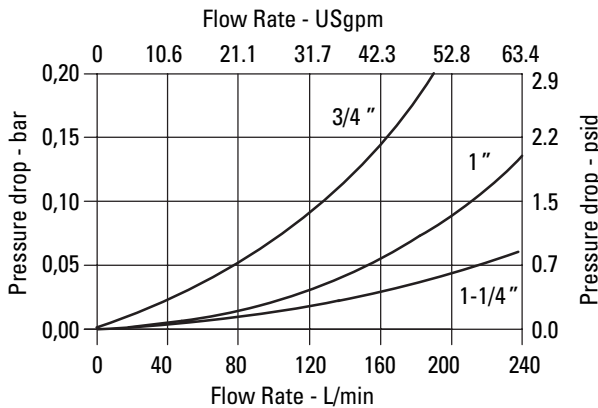

Bypass Valve

Based on mineral oil with density of 0,86 kg/dm³.
ΔP varies proportionally to density.

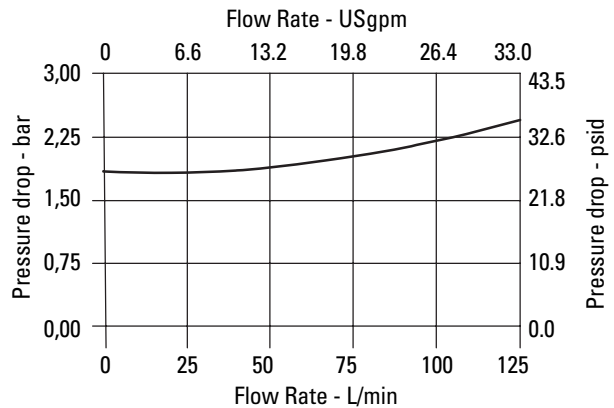

In-tank Filters

OFRT250 Series

Flows to 105 L/min (27.7 USgpm)
Pressures to 10 bar (150 PSI)



Features and Benefits

- High efficiency filter elements with superior dirt-holding capacity designed for return lines and installed semi-immersed in a reservoir.
- Excellent pressure drop characteristics.
- Indicators ordered separately
- Bowl length options for design flexibility.
- Easy element changes.
- Bypass valve prevents excessive pressure drop and prevents element collapse and release of retained contaminant's back into hydraulic system.
- Designed to comply with ISO standards

DESIGN SPECIFICATIONS

Rated flow:	Length 1	115 L/min (30.4 USgpm)
	Length 2	160 L/min (42.3 USgpm)
	Length 3	205 L/min (54.2 USgpm)
	Length 4	360 L/min (95.1 USgpm)
Fluid compatibility:	Compatible with most petroleum oil, water glycol, oil-in-water and water-in-oil fluids, Optional seals available for phosphate esters.	
Temp range:	-25°C to +110°C (-13°F to +230°F)	
Pressure rating:	Operating	10 bar (150 PSI)
	Fatigue	10 bar (150 PSI)
Material:	Head	Die Cast Aluminum
	Cover	Aluminum
Dry weight: (Approximate)	Length 1	3,9 kg. (8.60 lbs.)
	Length 2	4,1 kg. (9.04 lbs.)
	Length 3	4,6 kg. (10.14 lbs.)
	Length 4	4,8 kg. (10.58 lbs.)

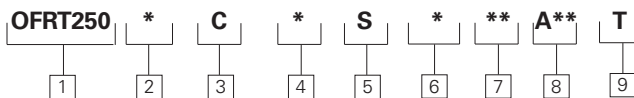

OFRT 250 Series Filter and Element Model Code

Sample model code:
OFRT2501COSAG7A06T

[1] Filter Series - OFRT 250

[2] Assembly Length

mm (inch)
1 - 285 (11.2)
2 - 335 (13.2)
3 - 405 (15.9)
4 - 610 (24.0)

Length given does not include diffuser

[3] Bypass Options

C - Bypass set at 25 PSI cracking pressure

[4] Diffuser Options

O - No diffuser
D - With diffuser

[5] Breather Options

S - No breather

[6] Seal Material

A - Buna-N
V - Viton-A

[7] Port Options (G-threaded, F-flanged)

G1 - 1-1/2" BSP
G2 - 1-1/2" and 1-1/4" dual BSP
G4 - 1-1/2" BSP
G5 - 1-1/2" and 1-1/4" dual NPT
G7 - SAE 24
G8 - SAE 20 and 24 dual
F1 - 1-1/2" SAE/Metric Bolt Holes
F2 - 1-1/2" and 1-1/4" dual SAE/Metric Bolt Holes
F3 - 1-1/2" SAE/Inch Bolt Holes
F4 - 1-1/2" and 1-1/4" SAE/Inch Bolt Holes

[8] Fluid Cleanliness Rating Target fluid

Code	cleanliness level
A06	18/16/14 or better
A10	20/18/15 or better

[9] Indicator Options

T - No Indicator (plug), No Connector

Items not in bold are non-standard and may have a longer lead time

In-tank Filters

OFRT250 Series

Flows to 105 L/min (27.7 USgpm)
Pressures to 10 bar (150 PSI)

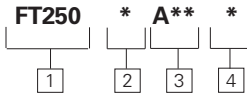

Element model code

Sample model code:

FT2502A06A

1 Filter Element - FT 250

2 Element Length

mm (inch)

1 - 175 (6.9)

2 - 225 (8.9)

3 - 295 (11.6)

4 - 500 (19.7)

3 Fluid Cleanliness Rating

Code Target fluid cleanliness level

A06 18/16/14 or better

A10 20/18/15 or better

4 Seal Material

A - Buna-N

V - Viton-A

Housing Dimensions

mm (inch)

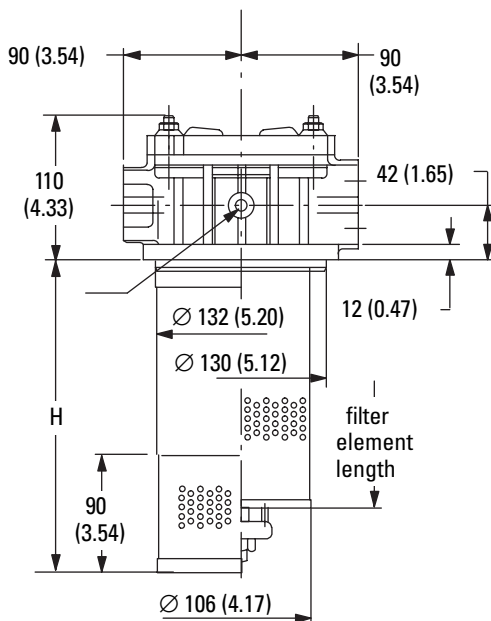
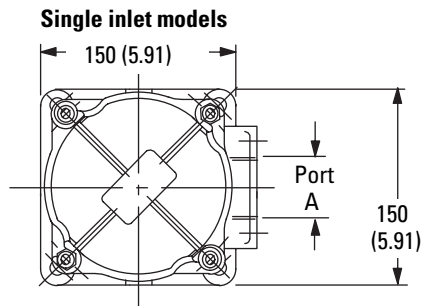
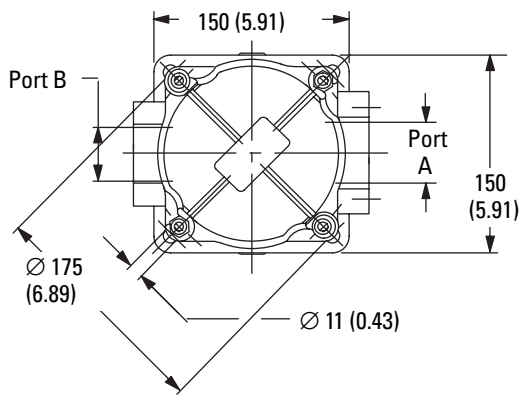

Items not in bold are non-standard and may have a longer lead time

In-tank Filters

OFRT250 Series

Flows to 105 L/min (27.7 USgpm)
Pressures to 10 bar (150 PSI)

Flow Data

Element Flow Data

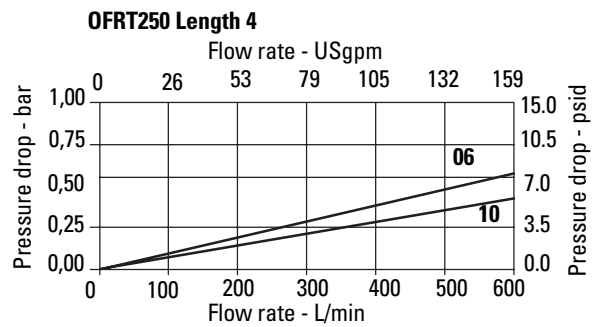
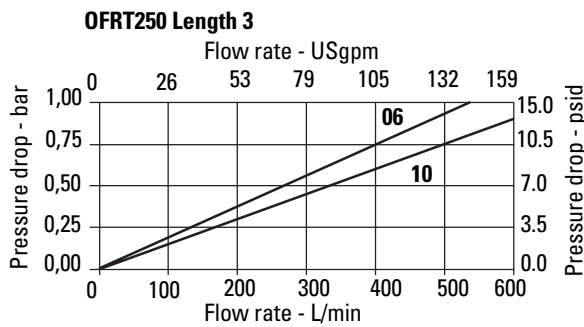
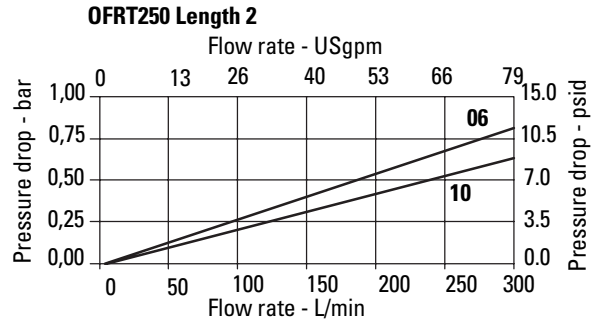
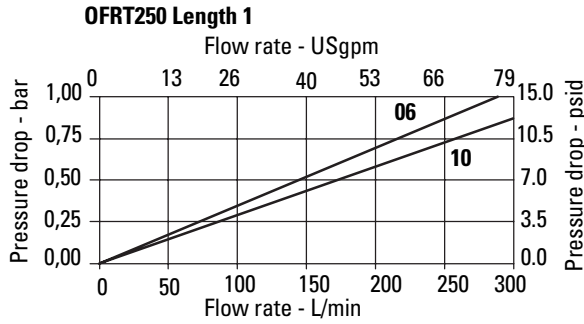

Housing/Bypass Valve Flow Data

Housing

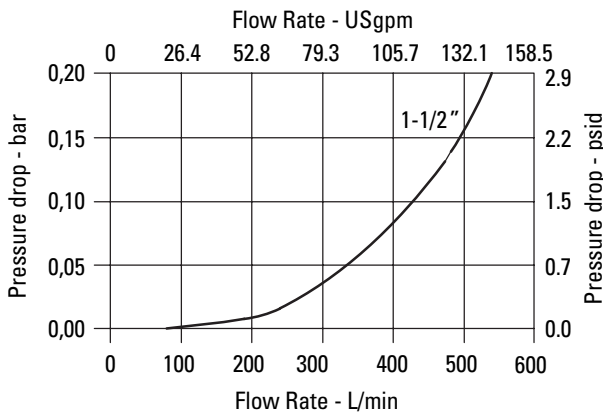

Bypass Valve

Based on mineral oil with density of 0,86 kg/dm³.
 ΔP varies proportionally to density.

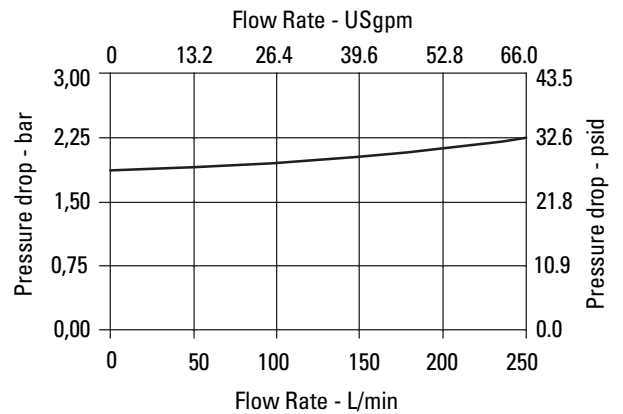

In-tank Filters

OFRT630 Series

Flows to 480 L/min (126.8 USgpm)
Pressures to 10 bar (150 PSI)



Features and Benefits

- High efficiency filter elements with superior dirt-holding capacity designed for return lines and installed semi-immersed in a reservoir.
- Excellent pressure drop characteristics.
- Indicators ordered separately.
- Bowl length options for design flexibility.
- Easy element changes.
- Bypass valve prevents excessive pressure drop and prevents element collapse and release of retained contaminant's back into hydraulic system.
- Designed to comply with ISO standards

DESIGN SPECIFICATIONS

Rated flow:	Length 1	320 L/min (84.5 USgpm)
	Length 2	400 L/min (105.7 USgpm)
	Length 3	440 L/min (116.2 USgpm)
	Length 4	480 L/min (126.8 USgpm)
Fluid compatibility:	Compatible with most petroleum oil, water glycol, oil-in-water and water-in-oil fluids, Optional seals available for phosphate esters.	
Temp range:	-25°C to 110°C (-13°F to 230°F)	
Pressure rating:	Operating	10 bar (150 PSI)
	Fatigue	10 bar (150 PSI)
Material:	Head	Die Cast Aluminum
	Cover	Aluminum
Dry weight: (Approximate)	Length 1	8,2 kg. (18.1 lbs.)
	Length 2	8,7 kg. (19.2 lbs.)
	Length 3	9,0 kg. (19.8 lbs.)
	Length 4	9,5 kg. (20.9 lbs.)

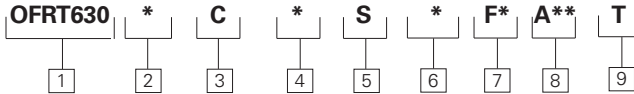

OFRT 630 Series Filter and Element Model Code

Sample model code:
OFRT6301COSAF3A06T

1 Filter Series - OFRT 630

2 Assembly Length

mm (inch)
1 - 400 (15.7)
2 - 480 (18.8)
3 - 580 (22.8)
4 - 670 (26.4)

Length given does not include diffuser

3 Bypass Options

C - Bypass set at 25 PSI cracking pressure

4 Diffuser Options

O - No diffuser
D - With diffuser

5 Breather Options

S - No breather

6 Seal Material

A - Buna-N
V - Viton-A

7 Port Options (G-threaded, F-flanged)

F1 - 2-1/2" SAE/Metric Bolt Holes
F2 - 2" and 2-1/2" dual SAE/Metric Bolt Holes
F3 - 2-1/2" SAE/Inch Bolt Holes
F4 - 2" and 2-1/2" dual SAE/Inch Bolt Holes

8 Fluid Cleanliness Rating Target fluid

Code	cleanliness level
A06	18/16/14 or better
A10	20/18/15 or better

9 Indicator Options

T - No Indicator (plug), No Connector

In-tank Filters

OFRT630 Series

Flows to 480 L/min (126.8 USgpm)
Pressures to 10 bar (150 PSI)

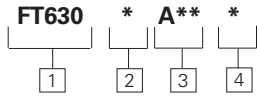

Element model code

Sample model code:

FT6302A06A

1 Filter Element - FT 630

2 Element Length

mm (inch)

1 - 260 (10.2)

2 - 340 (13.4)

3 - 440 (17.3)

4 - 530 (20.9)

3 Fluid Cleanliness Rating

Target fluid cleanliness level

A06 18/16/14 or better

A10 20/18/15 or better

4 Seal Material

A - Buna-N

V - Viton-A

Housing Dimensions

mm (inch)

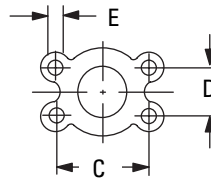
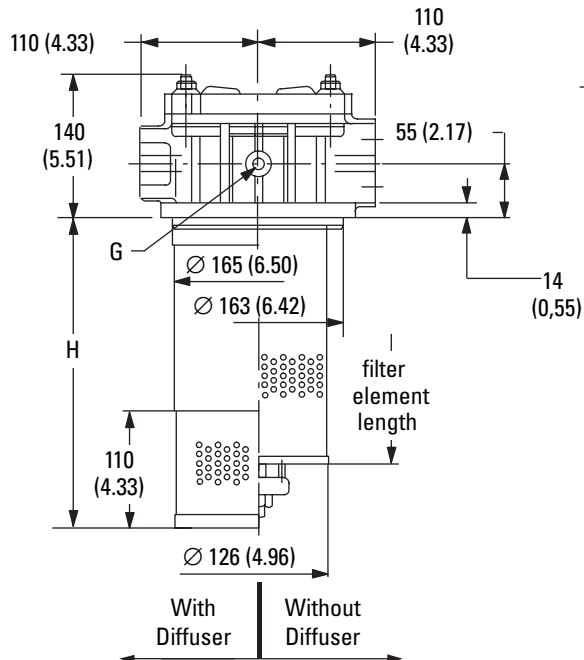
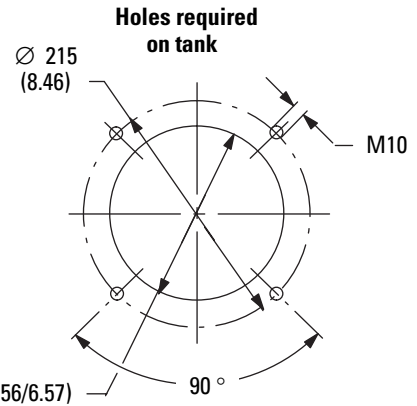
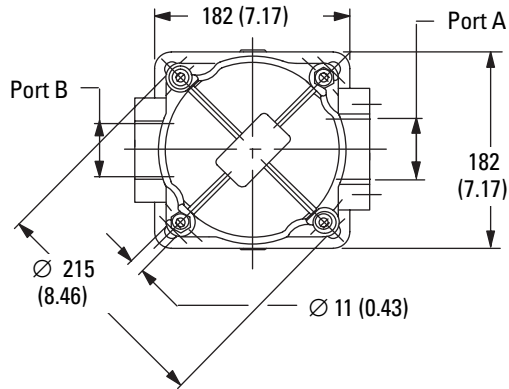

Items not in bold are non-standard and may have a longer lead time

In-tank Filters

OFRT630 Series

Flows to 480 L/min (126.8 USgpm)
Pressures to 10 bar (150 PSI)

Flow Data

Element Flow Data

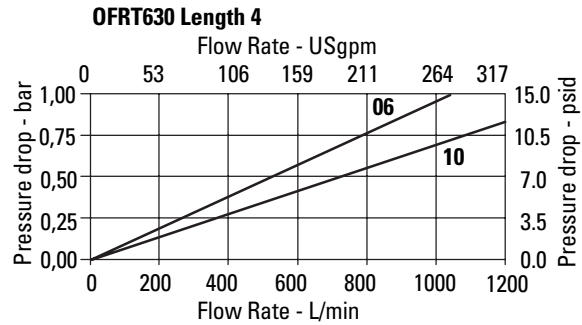
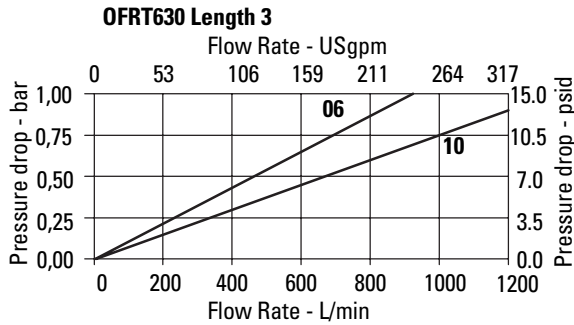
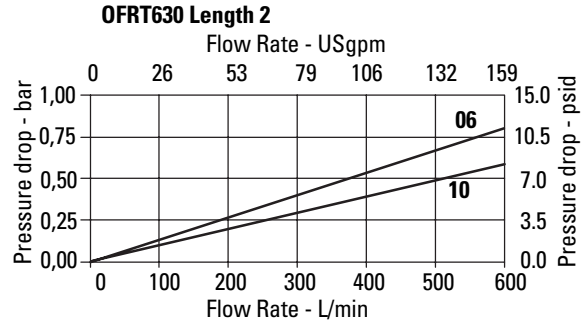
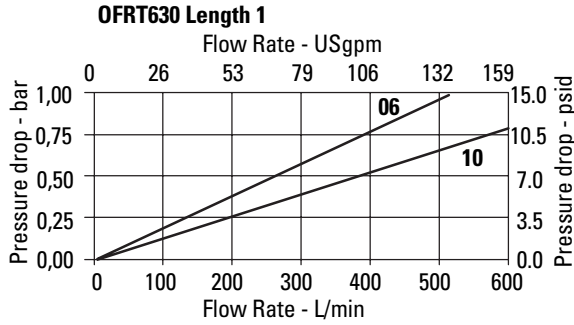

Housing/Bypass Valve Flow Data

Housing

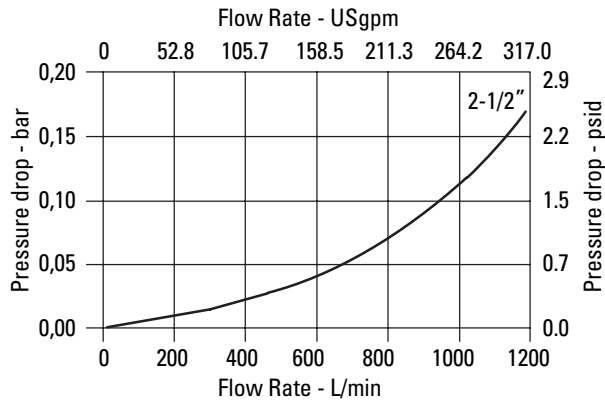

Bypass Valve

Based on mineral oil with density of 0,86 kg/dm³.
ΔP varies proportionally to density.

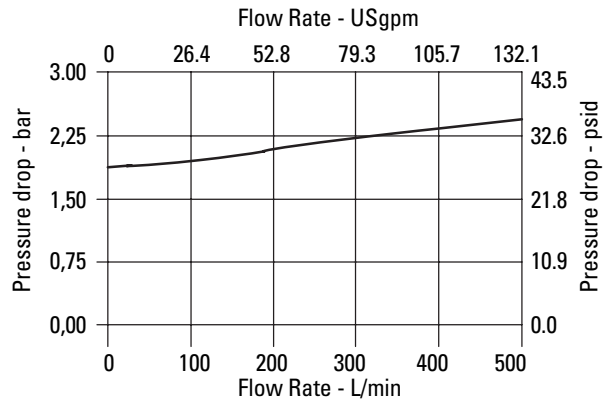

In-tank Filters

OFRT850 Series

Flows to 1500 L/min (396.3 USgpm)
Pressures to 10 bar (150 PSI)



Features and Benefits

- High efficiency filter elements with superior dirt-holding capacity designed for return lines and installed semi-immersed or totally immersed in a reservoir.
- Excellent pressure drop characteristics.
- Indicators ordered separately.
- Bowl length options for design flexibility.
- Easy element changes.
- Bypass valve prevents excessive pressure drop and prevents element collapse and release of retained contaminant's back into hydraulic system.
- Designed to comply with ISO standards

DESIGN SPECIFICATIONS

Rated flow:	Length 1	650 L/min (171.7 USgpm)
	Length 2	1000 L/min (264.2 USgpm)
	Length 3	1200 L/min (317.0 USgpm)
	Length 4	1500 L/min (396.3 USgpm)
Fluid compatibility:	Compatible with most petroleum oil, water glycol, oil-in-water and water-in-oil fluids, Optional seals available for phosphate esters.	
Temp range:	-25°C to 110°C (-13°F to 230°F)	
Pressure rating:	Operating	10 bar (150 PSI)
	Fatigue	10 bar (150 PSI)
Material:	Head	Die Cast Aluminum
	Cover	Steel
Dry weight: (Approximate)	Length 1	30 kg. (66.14 lbs.)
	Length 2	34 kg. (74.96 lbs.)
	Length 3	37 kg. (81.57 lbs.)
	Length 4	41 kg. (90.39 lbs.)

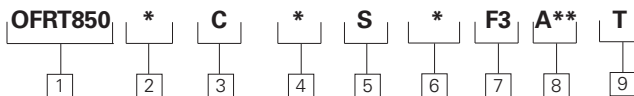

OFRT 850 Series Filter and Element Model Code

Sample model code:
OFRT8501COSAF3A06T

[1] Filter Series - OFRT 850

[2] Assembly Length

mm (inch)
1 - 572 (22.5)
2 - 787 (31.0)
3 - 1067 (42.0)
4 - 1332 (52.4)

[3] Bypass Options

C - Bypass set at 25 PSI cracking pressure

[4] Diffuser Options

O - No diffuser
D - With diffuser

[5] Breather Options

S - No breather

[6] Seal Material

A - Buna-N
V - Viton-A

[7] Port Options

F3 - DN 100 PN 10/16 3" SAE/Metric Bolt Holes

[8] Fluid Cleanliness Rating Target fluid

Code	cleanliness level
A06	18/16/14 or better
A10	20/18/15 or better

[9] Indicator Options

T - No Indicator (plug), No Connector

Items not in bold are non-standard and may have a longer lead time

In-tank Filters

OFRT850 Series

Flows to 1500 L/min (396.3 USgpm)
Pressures to 10 bar (150 PSI)

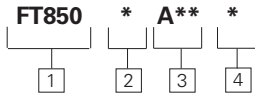

Element model code

Sample model code:

FT8502A06A

1 Filter Element - FT 850

2 Element Length

- mm (inch)
- 1** - 388 (15.2)
 - 2** - 603 (23.7)
 - 3** - 883 (34.7)
 - 4** - 1148 (45.2)

3 Fluid Cleanliness Rating

Code Target fluid cleanliness level

- A06** 18/16/14 or better
- A10** 20/18/15 or better

4 Seal Material

- A** - Buna-N
- V** - Viton-A

Housing Dimensions

mm (inch)

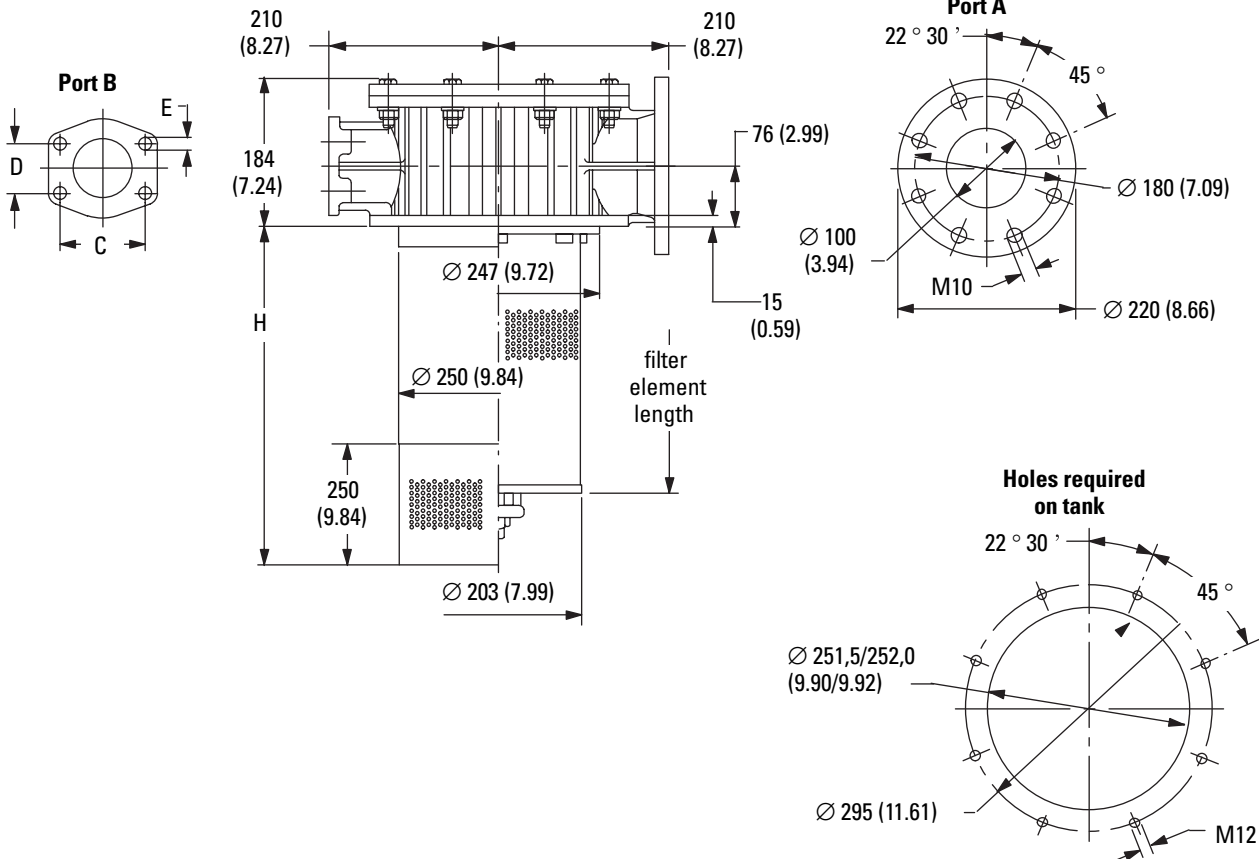
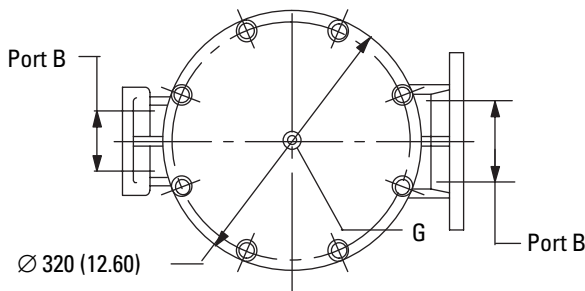

Items not in bold are non-standard and may have a longer lead time

In-tank Filters

OFRT850 Series

Flows to 1500 L/min (396.3 USgpm)
Pressures to 10 bar (150 PSI)

Flow Data

Element Flow Data

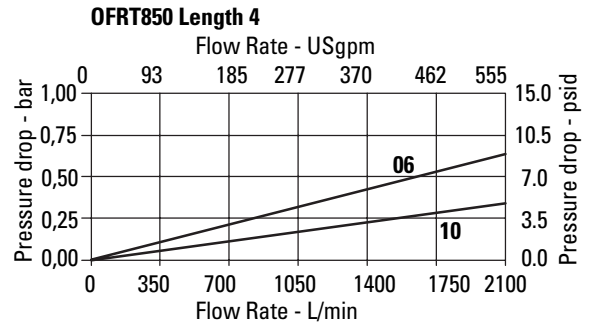
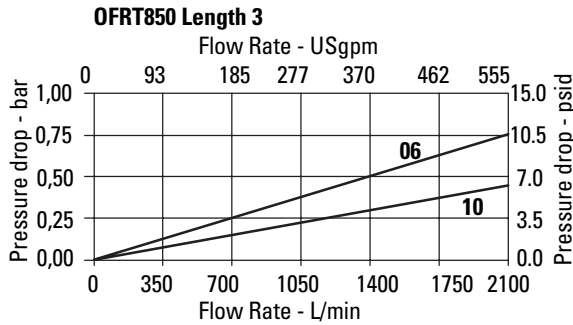
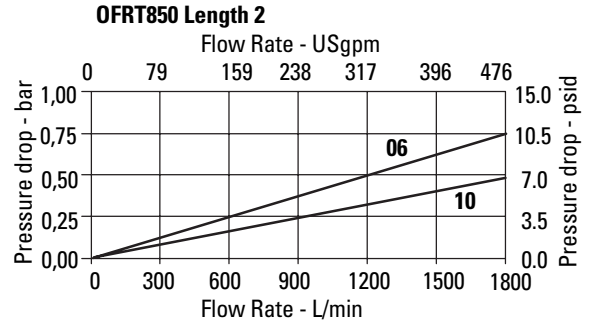
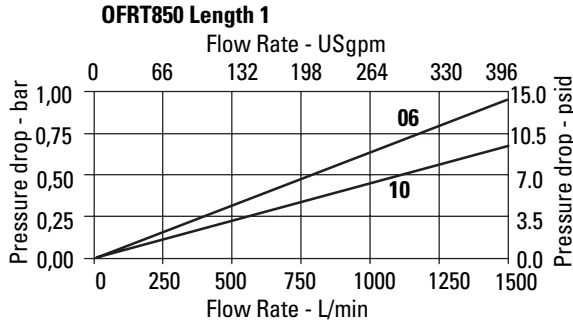

Housing/Bypass Valve Flow Data

Housing

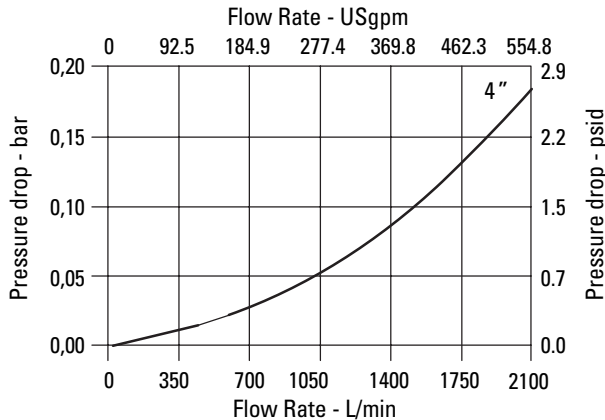

Bypass Valve

Based on mineral oil with density of 0,86 kg/dm³.
 ΔP varies proportionally to density.

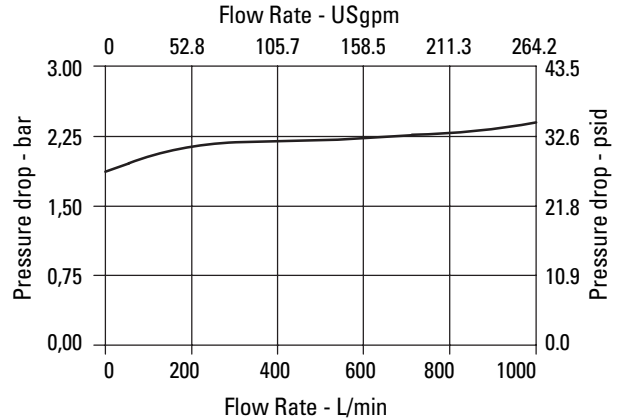

In-tank Filters

ORFM Series

Flows to 850 L/min (225 USgpm)
Pressures to 10 bar (145 PSI)



Features and Benefits

- Ideal for mobile applications due to lightweight and compact design
- Clogging indication cavities are standard
- Housing and lid are constructed of durable plastic polyamide or aluminum
- Aluminum alloy does not require anodizing for water-based fluids
- Lengths 2/3/4 have filter bowls that are removed to change the element and also serve as a contamination basket.
- Lengths 1/5/6/7 have filter elements that have a separate, reusable contamination basket

DESIGN SPECIFICATIONS

Rated flow:	Length 1	30 L/min (8 USgpm)	
	Length 2	75 L/min (20 USgpm)	
	Length 3	90 L/min (24 USgpm)	
	Length 4	165 L/min (43 USgpm)	
	Length 5	330 L/Min (87 USgpm)	
	Length 6	660 L/min (174 USgpm)	
	Length 7	850 L/min (225 USgpm)	
Fluid compatibility:	Compatible with all petroleum oil and synthetic fluids rated for use with fluoro-rubber or ethylene propylene seals.		
Temp range:	-30°C to +121°C (-22°F to +250°F)		
Pressure rating:	Operating	10 bar (145 PSI)	
	Fatigue	10 bar (145 PSI)	
Material:	Length 1	Head, Bowl, Lid	Plastic
	Length 2/3/4	Head	Aluminum
		Bowl, Lid	Plastic
	Length 5/6/7	Head, Bowl, Lid	Aluminum
Dry weight: (Approximate)	Length 1	.32 kg. (0.7 lbs)	
	Length 2	.59 kg. (1.3 lbs)	
	Length 3	.41 kg. (0.9 lbs)	
	Length 4	.68 kg. (1.5 lbs)	
	Length 5	3.1 kg. (6.8 lbs)	
	Length 6	6.0 kg. (13.2 lbs)	
	Length 7	6.5 kg. (14.3 lbs)	

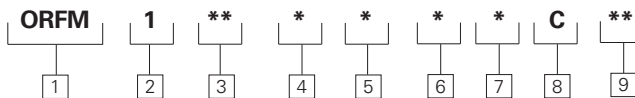

ORFM Series Filter and Element Model Code

Sample model code:
ORFM1SASC14B2C05

1 Filter Series- ORFM

2 Element Collapse Rating
1 - 145 PSI Low Collapse

3 Port Options
SA - NPT 1/2" – length 1 only
SB - SAE-16 (1" tube) – length 2 & 4 only
SC - SAE-12 (3/4" tube) – length 3 only
SD - SAE Flange (code 61) (1" tube) – length 5 only
SE - SAE-24 (1-1/2" tube) – length 5 only
SF - SAE Flange (code 61) (2" tube) – length 6 & 7 only

4 Valve Options
0 - No Bypass
1 - Bypass set at 25 PSI (1.7 bar) cracking pressure
2 - Bypass set at 43 PSI (3 bar) cracking pressure
3 - Bypass set at 87 PSI (6 bar) cracking pressure

5 Indicator Options
AN - Visual 70 PSI, No Connector
KN - Visual 15 PSI, No Connector

LN - Visual 30 PSI, No Connector
JN - No Indicator (plug), No Connector
MB - Electrical 15 PSI, Brad Harrison
MJ - Electrical 15 PSI, Hirshman w 24 volt light
MK - Electrical 15 PSI, Hirshman w 115 volt light
ML - Electrical 15 PSI, Hirshman w 230 volt light
MH - Electrical 15 PSI, Hirshman
RB - Electrical 30 PSI, Brad Harrison
RJ - Electrical 30 PSI, Hirshman w 24 volt light
RK - Electrical 30 PSI, Hirshman w 115 volt light
RL - Electrical 30 PSI, Hirshman w 230 volt light
RH - Electrical 30 PSI, Hirshman
UB - Electrical 70 PSI, Brad Harrison
UJ - Electrical 70 PSI, Hirshman w 24 volt light
UK - Electrical 70 PSI, Hirshman w 115 volt light
UL - Electrical 70 PSI, Hirshman w 230 volt light

UH - Electrical 70 PSI, Hirshman
GA - Gauge 0-4 Bar (0-60 psi). Use with valve option "1"
GB - Gauge 0-10 Bar (0-160 psi). Use with valve option "2"

6 Seal Material
B - Buna-N
V - Viton-A

7 Assembly Length
mm (inch)
1 - 156 (6.2)
2 - 204.8 (8.1)
3 - 246 (9.6)
4 - 288.8 (11.4)
5 - 270 (10.6)
6 - 426 (16.8)
7 - 507 (19.9)

8 Element Construction
C - Standard Construction

9 Fluid Cleanliness Rating

Code	Target fluid cleanliness level
05	18/16/14 or better
10	20/18/15 or better
20	22/19/16 or better

Items not in bold are non-standard and may have a longer lead time

In-tank Filters

ORFM Series

Flows to 850 L/min (225 USgpm)
Pressures to 10 bar (145 PSI)

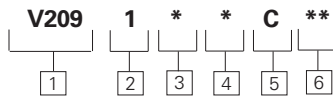

V209 Element model code

Sample model code:

V2091B3C10

1 Filter Element - V209

2 Element Collapse Rating

1 - 145 PSI Low Collapse

3 Seal Material

B - Buna-N
V - Viton-A

4 Assembly Length

mm (inch)
1 - 156 (6.1)
2 - 204.8 (8.1)
3 - 246 (9.5)
4 - 288.8 (11.3)
5 - 270 (10.6)
6 - 426 (16.8)
7 - 507 (19.9)

5 Element Construction

C - Standard Construction

6 Fluid Cleanliness Rating

Code	Target fluid cleanliness level
05	18/16/14 or better
10	20/18/15 or better
20	22/19/16 or better

Housing Dimensions

mm (inch)

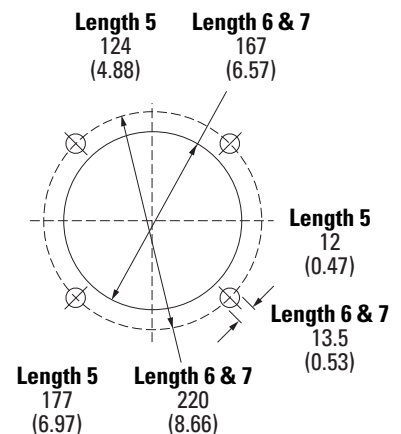
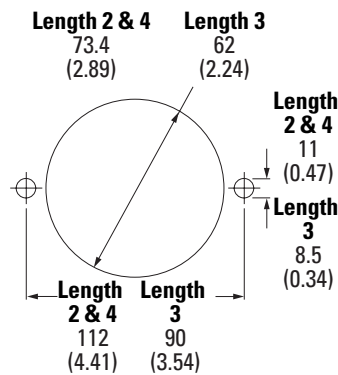
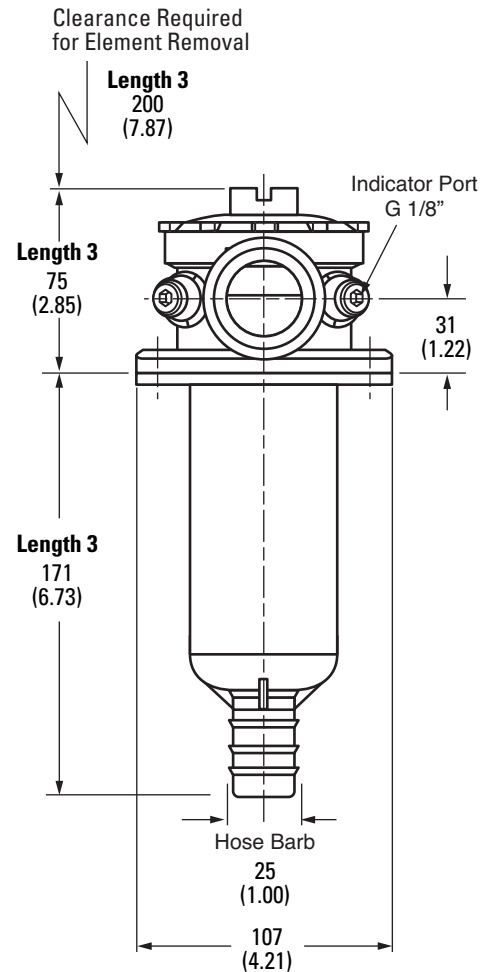
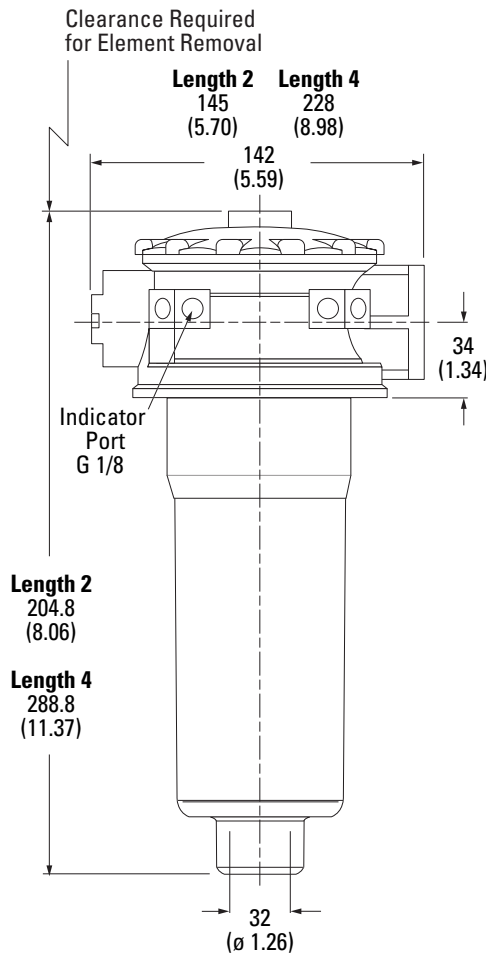
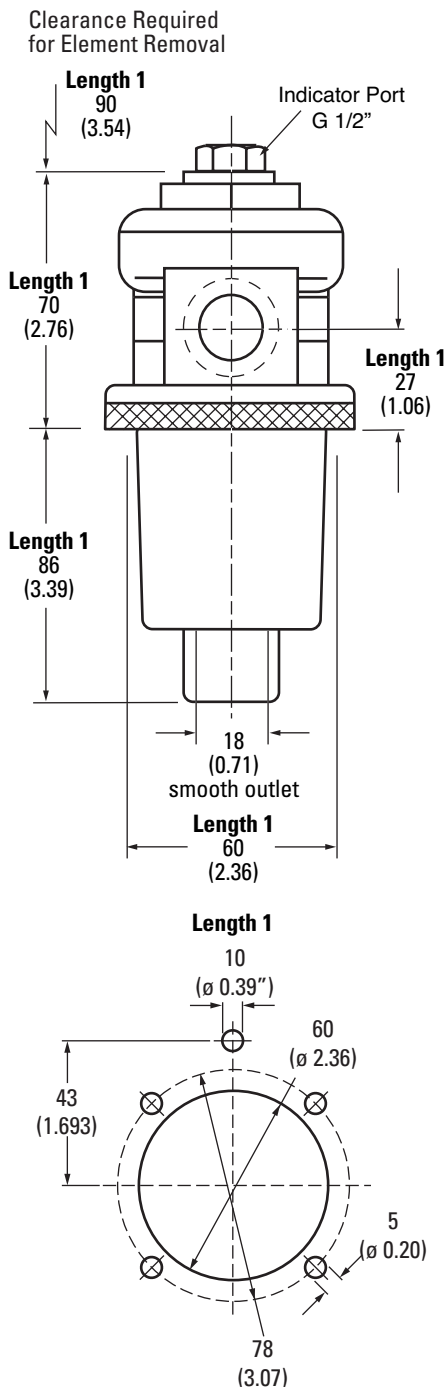

Items not in bold are non-standard and may have a longer lead time

In-tank Filters

ORFM Series

Housing Dimensions

mm (inch)

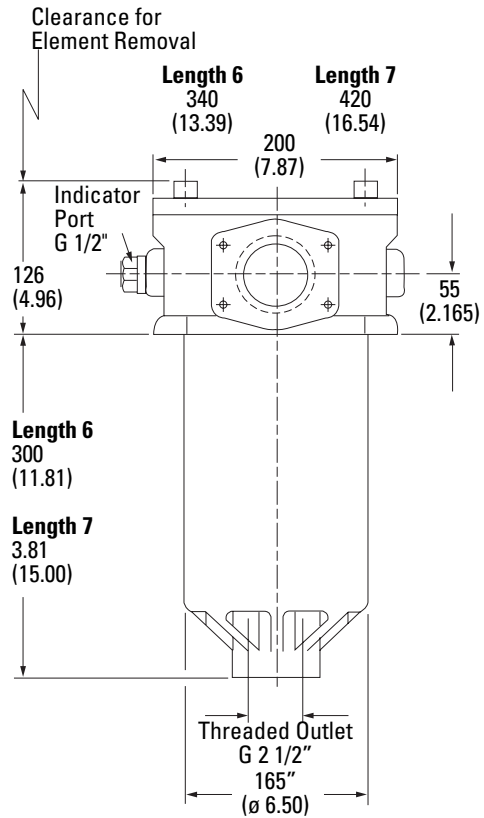
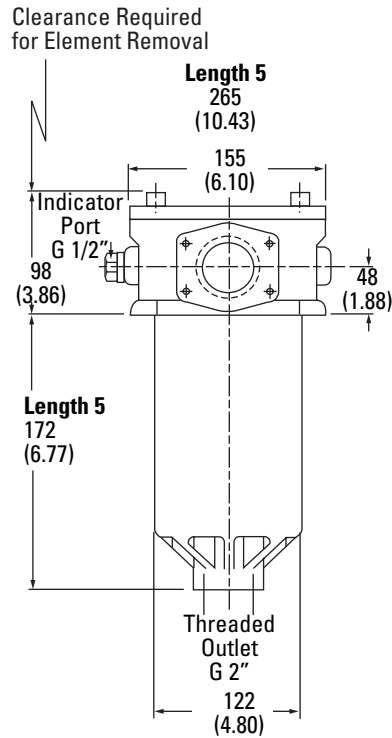

In-tank Filters

ORFM Series

Clogging Indicator Locations

Flows to 850 L/min (225 USgpm)
Pressures to 10 bar (145 PSI)

ORFM Clogging Indicator Locations

LENGTH	LOCATION OF CLOGGING INDICATOR
1	Clogging Indicator on top centerline
2/4	Clogging Indicator Left Back 90° to inlet
3	Clogging Indicator Left Front 45° to inlet
5	Clogging Indicator Left Side 90° to inlet
6/7	Clogging Indicator Left Side 90° to inlet

In-tank Filters

Flows to 1320 L/min (349 USgpm)
Pressures to 10 bar (145 PSI)

ORFM Series

Flow versus pressure drop:

Flow Data

150 SUS (32 cSt) oil with specific gravity of ≤ 0.9

Housing/Bypass Valve

Flow Data

ORFM C-Pak Length 1

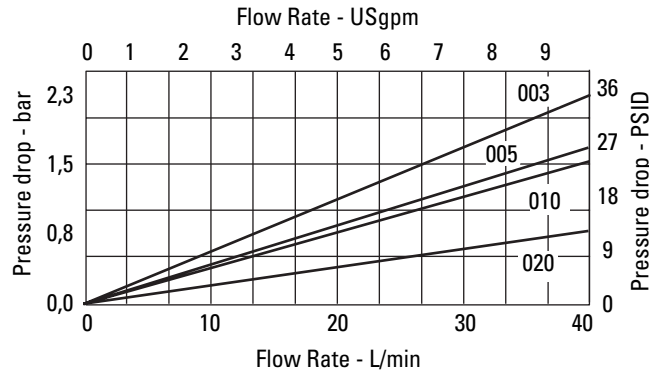

ORFM C-Pak Length 2

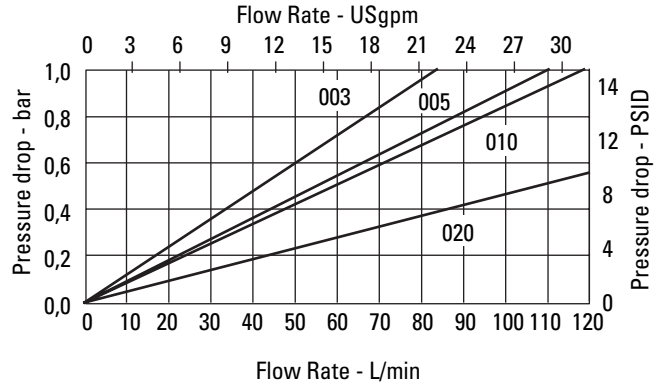

ORFM C-Pak Length 3

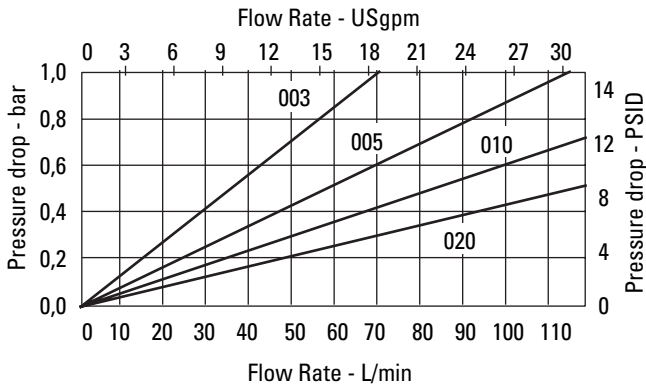

ORFM C-Pak Length 4

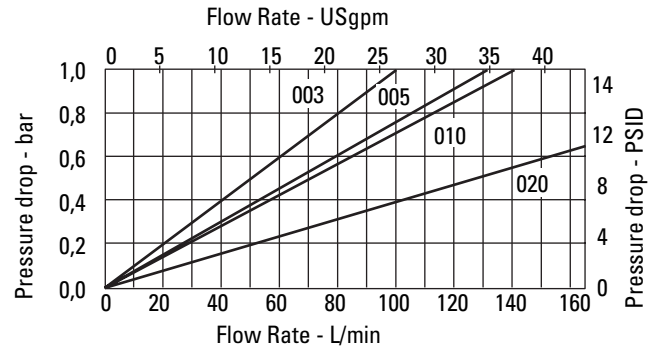

ORFM C-Pak Length 5

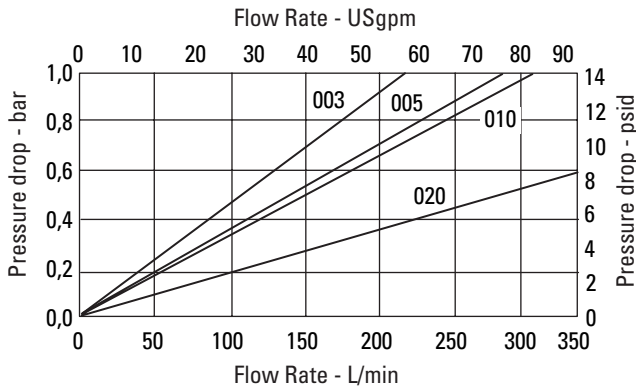

ORFM C-Pak Length 6

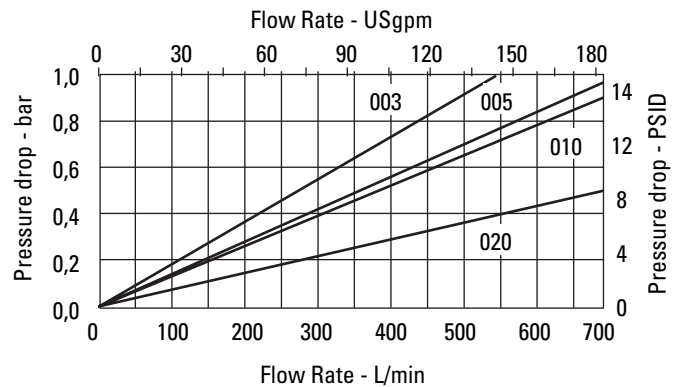

ORFM C-Pak Length 7

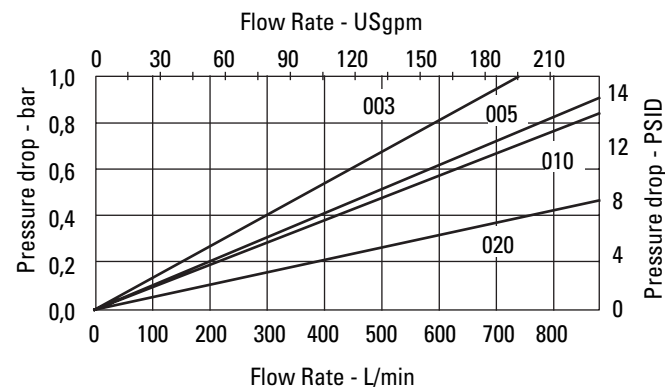

In-tank Filters

ORFM Series

Flow Data

Flows to 1320 L/min (349 USgpm)
Pressures to 10 bar (145 PSI)

Flow versus pressure drop:

150 SUS (32 cSt) oil with specific gravity of ≤ 0.9

Housing/Bypass Valve

Flow Data

ORFM Length 1 Housing

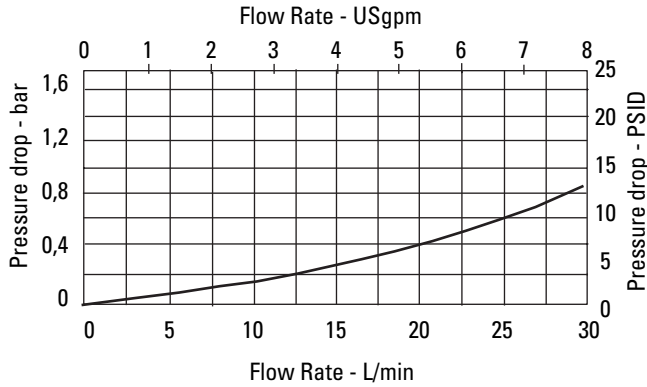

ORFM Length 1 Bypass

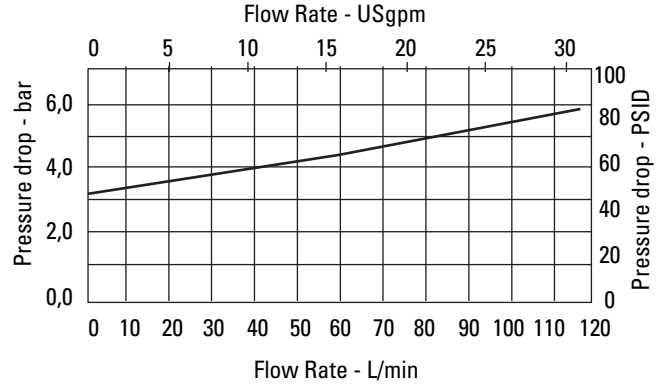

ORFM Length 2 & 4 Housing

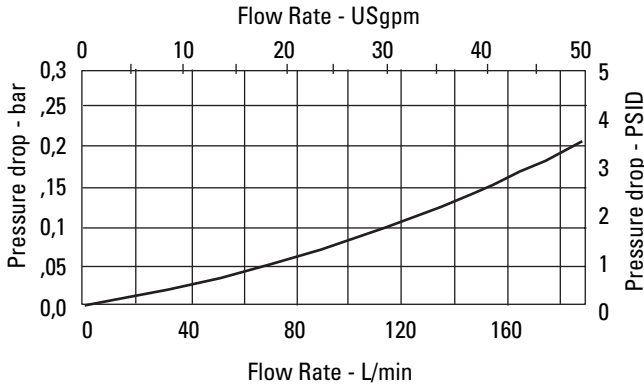

ORFM Length 2/4 Bypass

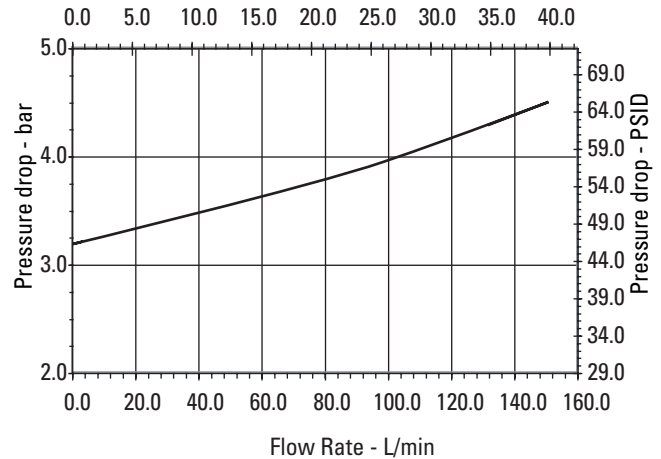

ORFM Length 3 Housing

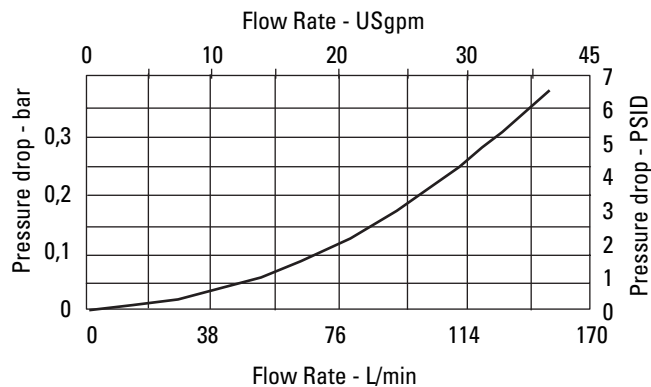

ORFM Length3 Bypass

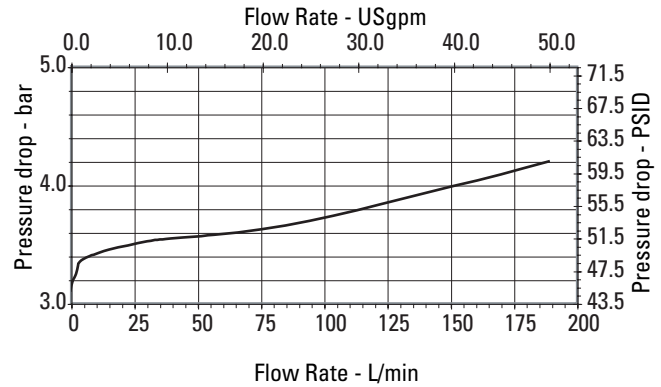

In-tank Filters

ORFM Series

Flow Data

Housing/Bypass Valve

Flow Data

Flows to 1320 L/min (349 USgpm)
Pressures to 10 bar (145 PSI)

Flow versus pressure drop:

150 SUS (32 cSt) oil with specific gravity of ≤ 0.9

ORFM Length 5 Housing

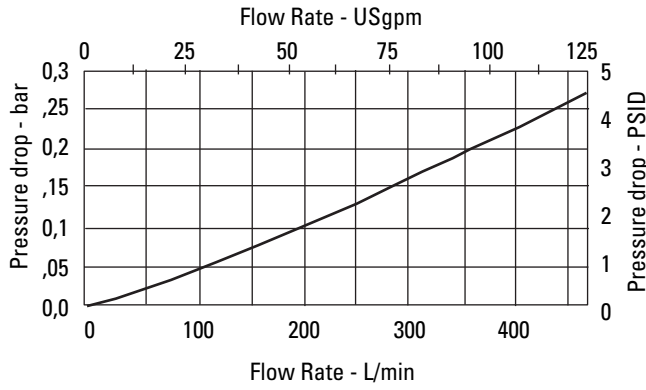

ORFM Length 5 Bypass

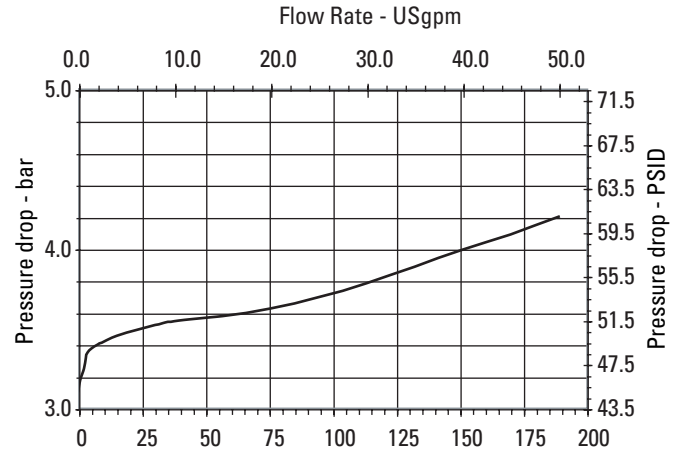

ORFM Length 6 & 7 Housing

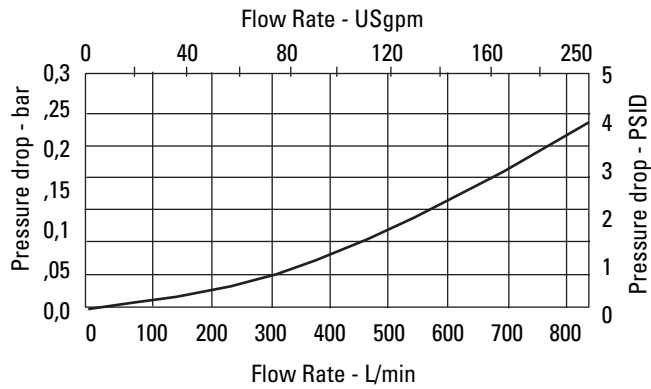

ORFM Length 6 & 7 Bypass

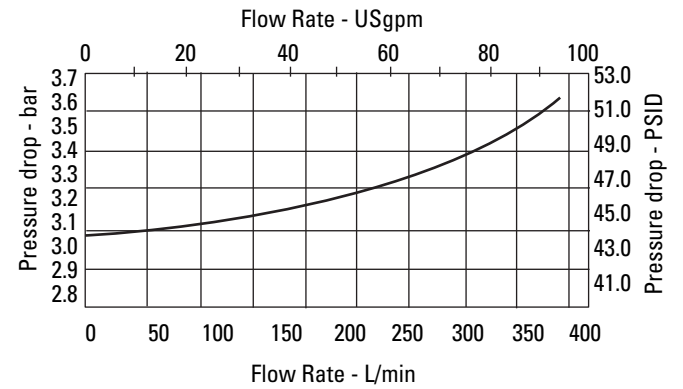

Items not in bold are non-standard and may have a longer lead time

In-tank Filters

ORF 1300

Flows to 1300 L/min (343 USgpm)
Pressures to 25 bar (360PSI)



Features and Benefits

- Non-welded housing design reduces stress concentrations prevents fatigue failure.
- O-ring seals are used to provide positive, reliable sealing.
- Bolt-on lid requires minimal clearance for removal.
- Reusable contamination basket prevents loss of retained contaminant's into the reservoir during element replacement.
- Clogging indicators can be serviced without interruption of the hydraulic system.
- Single piece casting provides rigidity for inline or in-tank mounting.

DESIGN SPECIFICATIONS

Rated flow:	Length 1	1300 L/min (343 USgpm)
Fluid compatibility:	Compatible with all petroleum oils and synthetic fluids rated for use with Fluoro-Rubber or Ethylene Propylene seals.	
Temp range:	-30°C to + 121°C (-22°F to 250°F)	
Pressure rating:	Operating	25 bar (360 PSI)
	Fatigue	25 bar (360 PSI)
Material:	Housing, Lid, Transfer Valve:	Ductile Iron
Dry weight: (Approximate)	Length 1	43kg (94.8 lbs)

ORF 1300 Series Filter and Element Model Code

Sample model code:

ORF1F2JNB1C05

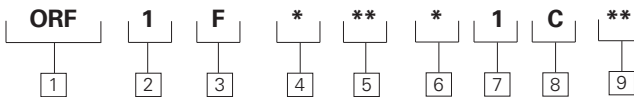

1 Filter Series - ORF

2 Element Collapse Rating

1 - 250 PSI Low Collapse

3 Port Options

F - 4" SAE Flange, Code 61

4 Valve Options

- 0** - Non-Bypass
- 1** - Bypass set at 25 PSI cracking pressure
- 2** - Bypass set at 43 PSI cracking pressure
- 3** - Bypass set at 87 PSI cracking pressure

5 Indicator Options

- AN** - Visual 70 PSI, No Connector
- KN** - Visual 15 PSI, No Connector
- LN** - Visual 30 PSI, No Connector
- JN** - No Indicator (plug), No Connector
- MB** - Electrical 15 PSI, Brad Harrison
- MJ** - Electrical 15 PSI, Hirshman w 24 volt light

MK - Electrical 15 PSI, Hirshman w 115 volt light

ML - Electrical 15 PSI, Hirshman w 230 volt light

MH - Electrical 15 PSI, Hirshman

RB - Electrical 30 PSI, Brad Harrison

RJ - Electrical 30 PSI, Hirshman w 24 volt light

RK - Electrical 30 PSI, Hirshman w 115 volt light

RL - Electrical 30 PSI, Hirshman w 230 volt light

RH - Electrical 30 PSI, Hirshman

UB - Electrical 70 PSI, Brad Harrison

UJ - Electrical 70 PSI, Hirshman w 24 volt light

UK - Electrical 70 PSI, Hirshman w 115 volt light

UL - Electrical 70 PSI, Hirshman w 230 volt light

UH - Electrical 70 PSI, Hirshman

GA - Gauge 0-4 Bar (0-60 psi). Use with valve option "1"

GB - Gauge 0-10 Bar (0-160 psi). Use with valve option "2"

6 Seal Material

- B** - Buna-N
- V** - Viton-A

7 Assembly Length

mm (inch)
1 - 584 (23.0)

8 Element Construction

C - Standard Construction

9 Fluid Cleanliness Rating

Code	Target fluid cleanliness level
03	16/14/12 or better
05	18/16/14 or better
10	20/18/15 or better
20	22/19/16 or better

Items not in bold are non-standard and may have a longer lead time

In-tank Filters

ORF 1300

Flows to 1300 L/min (343 USgpm)
Pressures to 25 bar (360PSI)

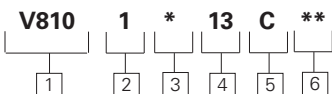

Element model code

Sample model code:

V8101B1C10

1 Filter element - V810

2 Element Collapse Rating

1 - 250 PSI Low Collapse

3 Seal material

B - Buna-N

V - Viton-A

7 Element Length

mm (inch)

1 - 253 (9.96)

8 Element construction

C - Standard Construction

9 Fluid cleanliness rating

Code	Target fluid cleanliness level
03	16/14/12 or better
05	18/16/14 or better
10	20/18/15 or better
20	22/19/16 or better

Housing Dimensions

mm (inch)

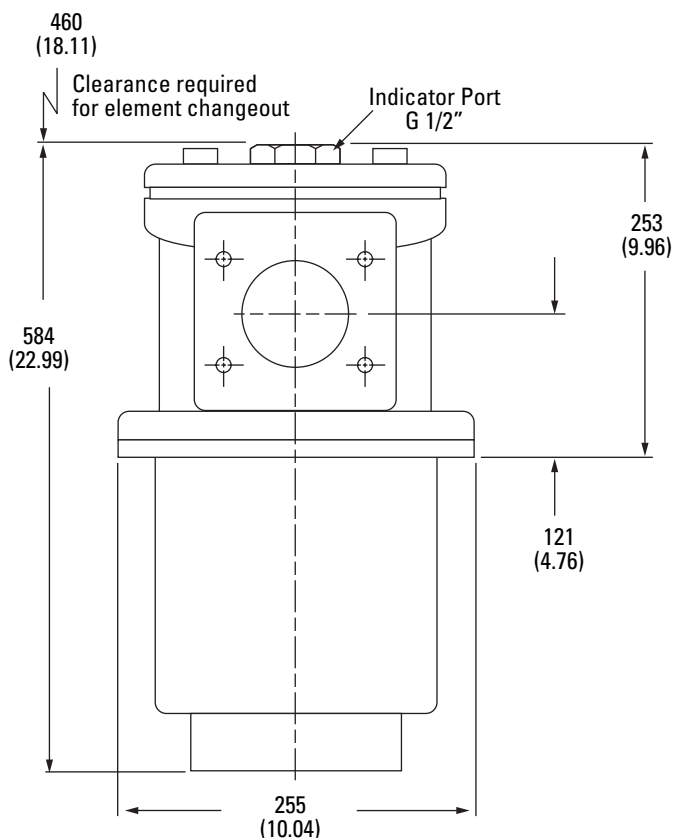

Mounting Pattern

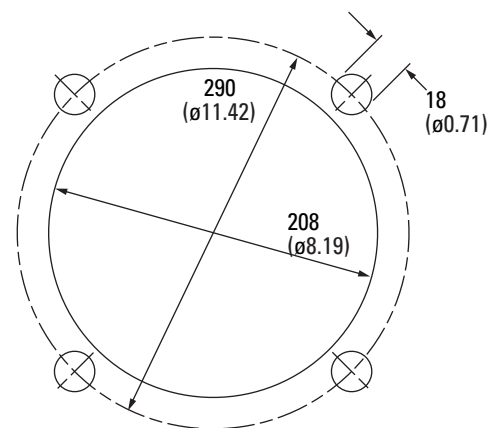

Items not in bold are non-standard and may have a longer lead time

In-tank Filters

ORF 1300

Flow Data

Flows to 1300 L/min (343 USgpm)
Pressures to 25 bar (360PSI)

Flow versus pressure drop:

150 SUS (32 cSt) oil with specific gravity of ≤ 0.9

Element Flow Data

Element Flow

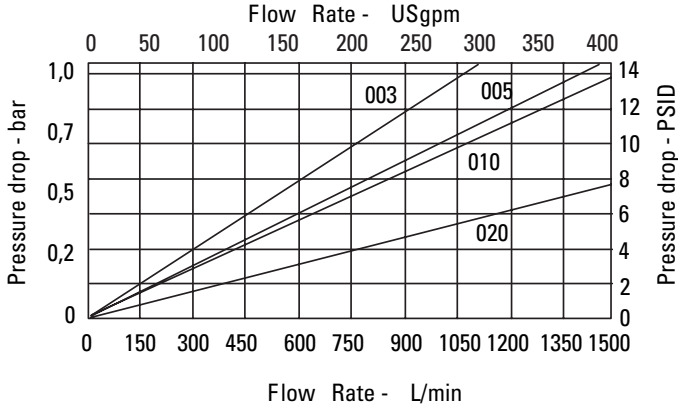

Housing

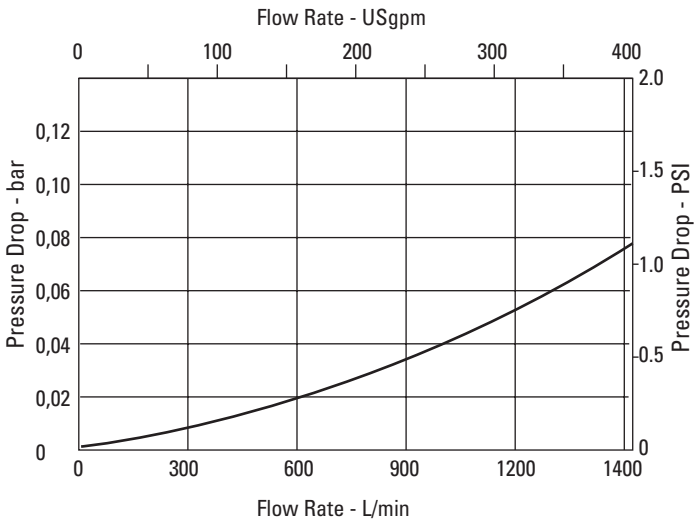

Bypass Valve

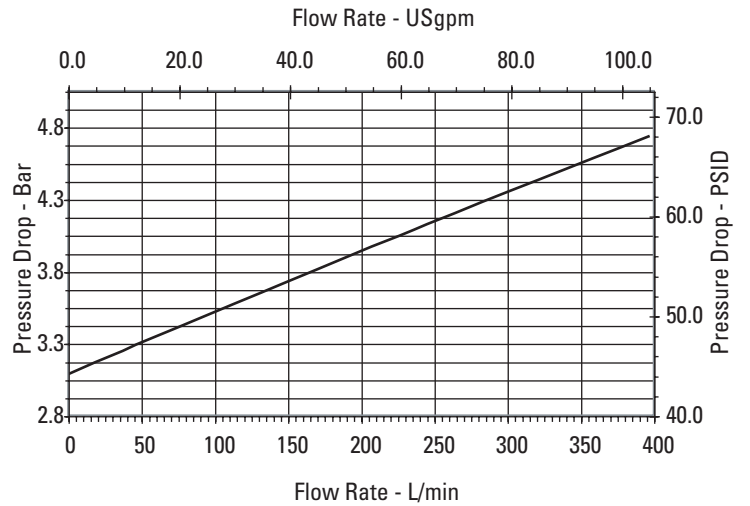

In-tank Filters

DRT DIN Series Filters

Flows to 630 (166 USgpm)
Pressures to 10 bar (145 PSI)



Features and Benefits

- Gauge and electrical switch options available to monitor element loading
- In-tank configuration minimizes space requirements and potential system leakage points.
- High efficiency replacement elements in standard configurations (C-Pak) to meet Target Cleanliness Levels

DESIGN SPECIFICATIONS

Rated flow:	040 063 100 160 250 400 630	40 L/min (11USgpm) 63 L/min (17USgpm) 100 L/min (26USgpm) 160 L/min (42USgpm) 250 L/min (66USgpm) 400 L/min (106USgpm) 630L/min (166USgpm)
Fluid compatibility:	Compatible with most petroleum oil, oil-in-water and water-in-oil fluids. Optional seals available for phosphate esters	
Temp range:	-10°C to + 100°C (+14°F to +212°F)	
Pressure rating:	Operating	25 bar (363 PSI)
Material:	Aluminum	
Dry weight:	040 063 100 160 250 400 630	1,5 kg (3.3lbs) 1,5 kg (3.3lbs) 1,5kg (3.3lbs) 3,8kg (8.4lbs) 3,8kg (8.4lbs) 9,0kg (19.8lbs) 9,0kg (19.8lbs)

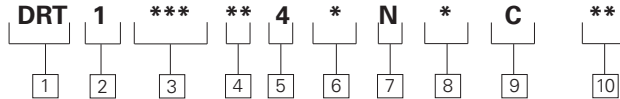

DLR Series Filter

Sample model code:

DRT1100BC41NBC06

1 Filter Series

DRT - DIN In-Tank

2 Element Collapse Rating

1 - Low Collapse

3 Nominal Size

040 - 40 L/min (11USgpm)
063 - 63 L/min (17USgpm)
100 - 100 L/min (26USgpm)
160 - 160 L/min (42USgpm)
250 - 250 L/min (66USgpm)
400 - 400 L/min (106USgpm)
630 - 630L/min (166USgpm)

4 Port Size

BB - G 1/2" (Length 040 only)
BC - G 3/4" (Length 063 only)
BD - G 1" (Length 100 only)
BE - G 1 1/4" (Length 160 only)
BF - G 1 1/2" (Length 250 only)
BM - DN 64 (Length 400 and 630 only)

5 Valve Options

4 - Bypass set at 50 PSI cracking pressure

6 Indicator Options

1 - None
2 - 0-10 Bar Gauge
9 - Electrical Switch Hirschman

7 Secondart Port

N - No Secondary Port

8 Seal Material

B - Buna-N
V - Viton-A

9 Element Construction

C - Standard Construction

10 Fluid Cleanliness Rating

Code	Target fluid cleanliness level
03	16/14/12 or better
06	18/16/14 or better
10	20/18/15 or better
25	22/19/16 or better

Items not in bold are non-standard and may have a longer lead time

In-tank Filters

DRT DIN Series Filters

Flows to 630 (166 USgpm)
Pressures to 10 bar (145 PSI)

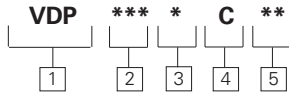

Element model code

Sample model code:

VDP160BC06

1 Filter Element
VDT - DIN Standard Element

2 Nominal Size
040 - 40 L/min (11USgpm)
063 - 63 L/min (17USgpm)
100 - 100 L/min (26USgpm)
160 - 160 L/min (42USgpm)
250 - 250 L/min (66USgpm)
400 - 400 L/min (106USgpm)
630 - 630L/min (166USgpm)

3 Seal Material
B - Buna-N
V - Viton-A

4 Element Construction
C - Standard Construction

5 Fluid Cleanliness Rating

Code	Target fluid cleanliness level
03	16/14/12 or better
06	18/16/14 or better
10	20/18/15 or better
25	22/19/16 or better

Dimensions DRT 040, 063, 100 Series

Dimensions in mm

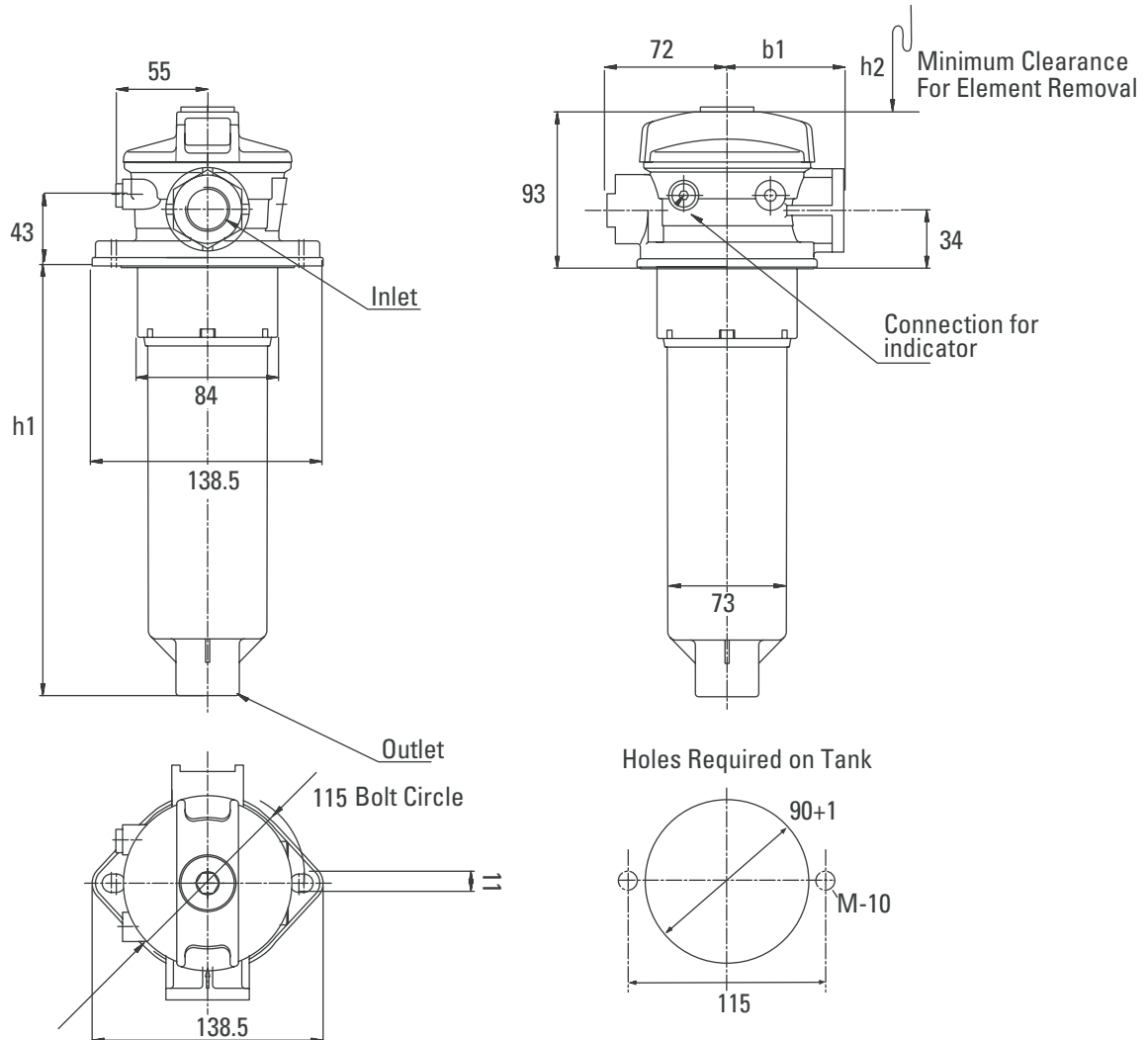

Items not in bold are non-standard and may have a longer lead time

In-tank Filters

DRT DIN Series

Filters

Flows to 630 (166 USgpm)
 Pressures to 10 bar (145 PSI)

Dimensions DRT 160 and 250 Series

Dimensions in mm

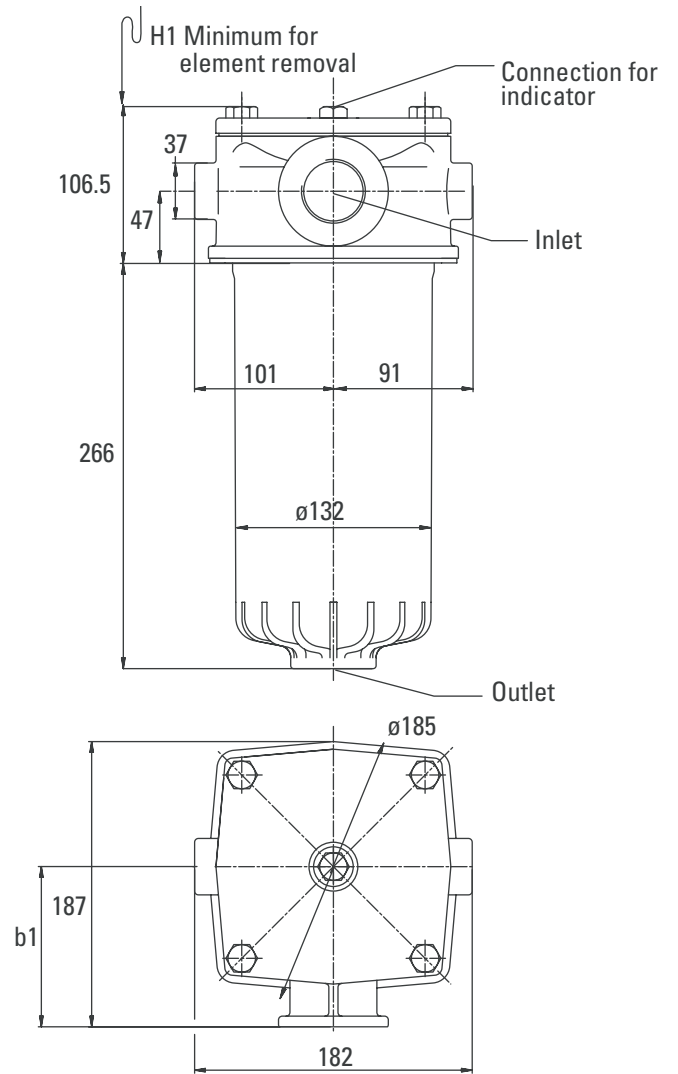
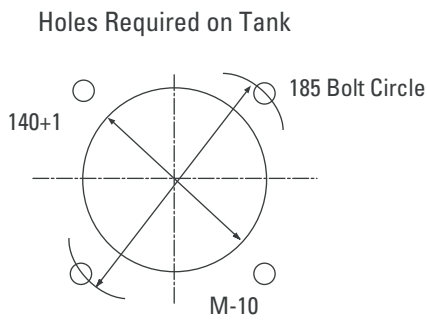

In-tank Filters

DRT DIN Series Filters

Flows to 630 (166 USgpm)
Pressures to 10 bar (145 PSI)

Housing Flow Data

DRT 040, 063, 100 Series Housing Data

Flow versus pressure drop:

32 cSt oil with specific gravity of ≤ 0.9

(See page 5 for specific gravity corrections for pressure drop.)

TYPE	INLET PORT	B1	H1	H2
DRT 040	G 1/2	81	122	150
DRT 063	G 3/4	70	206	200
DRT 100	G 1	70	260	290

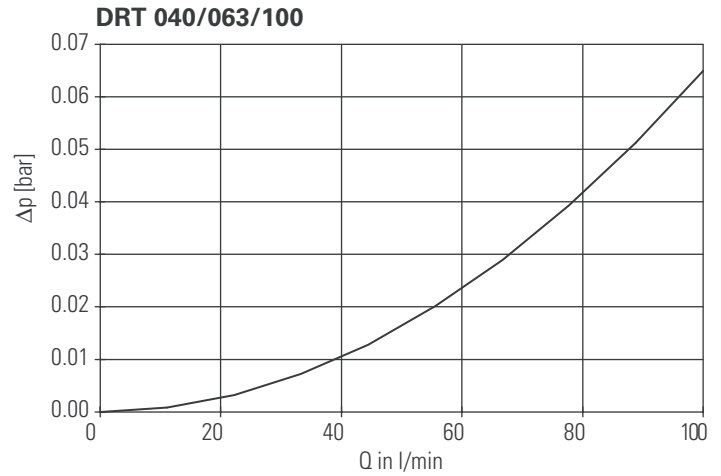

DRT 160 and 250 Series Housing Data

Flow versus pressure drop:

32 cSt oil with specific gravity of ≤ 0.9

(See page 5 for specific gravity corrections for pressure drop.)

TYPE	INLET PORT	B1	H1
DRT 160	G 1 1/4	141	210
DRT 250	G 1 1/2	105	300

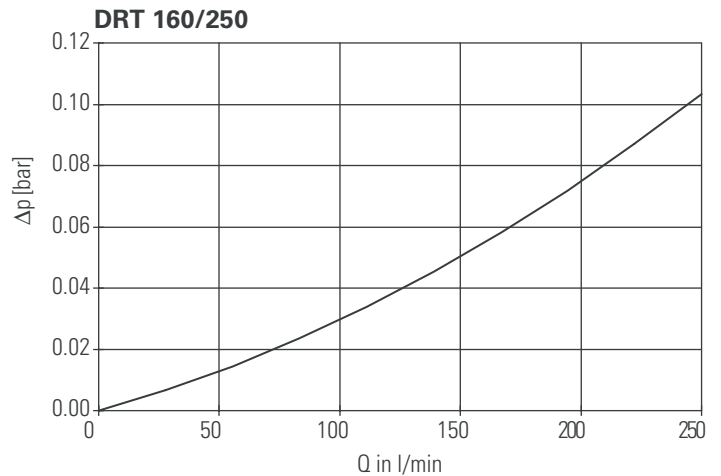

In-tank Filters

DRT DIN Series

Filters

Flows to 630 (166 USgpm)
 Pressures to 10 bar (145 PSI)

Element Flow Data

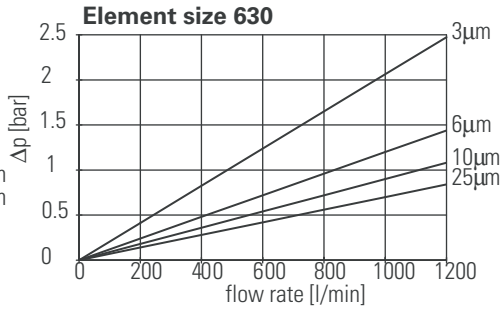
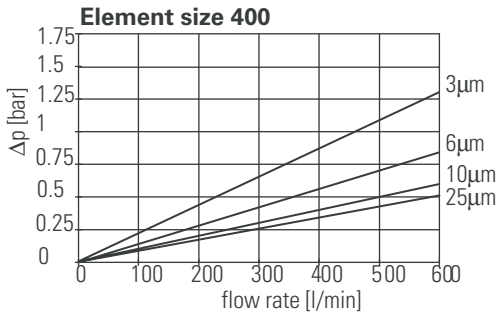
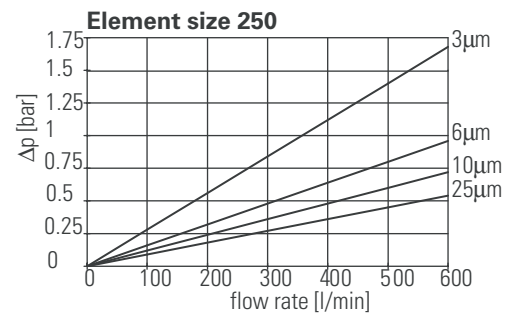
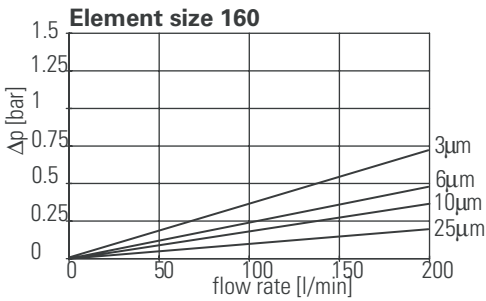
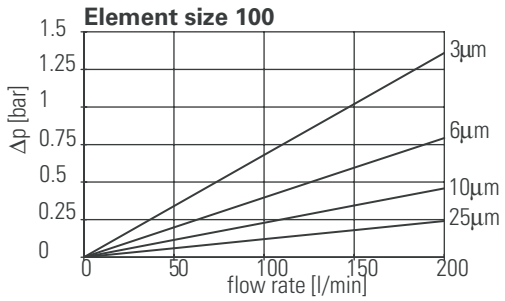
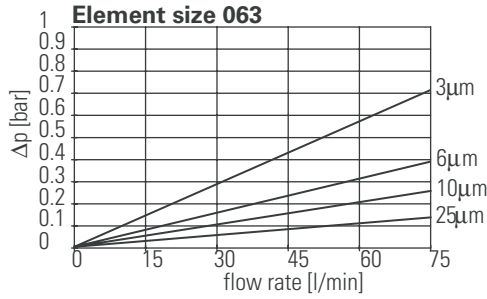
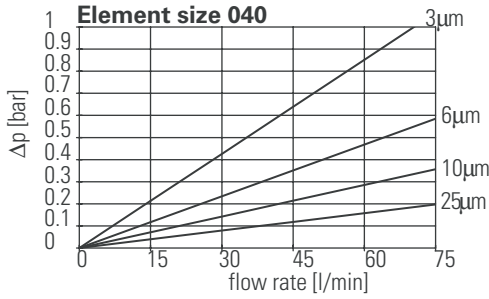

In-tank Filters

OSS Suction Strainers

Flows to 380 L/min (100 USgpm)



Features and Benefits

- Filters coarse particulate to prevent filter damage

Note:

Check or verify inlet condition before use.

DESIGN SPECIFICATIONS

Rated flow:	Length 1	30 L/min (8 USgpm)
	Length 2 w/1 1/4" NPT	75 L/min (20 USgpm)
	Length 2 w/1 1/2" NPT	115 L/min (30 USgpm)
	Length 3	190 L/min (50 USgpm)
	Length 4 w/1 1/4" NPT	380 L/min (100 USgpm)
Fluid compatibility:	Compatible with all petroleum oils and synthetic fluids rated for use with Fluoro-Rubber or Ethylene Propylene seals.	
Temp range:	-28 to +100°C (-20 to +210°F)	
Material:	Wire Mesh	Steel
	Fittings	Nylon
Dry weight:	Length 1	0,2 kg. (0.4 lbs.)
	Length 2	0,3 kg. (0.6 lbs.)
	Length 3	0,5 kg. (1.1 lbs.)
	Length 4	0,8 kg. (1.8 lbs.)

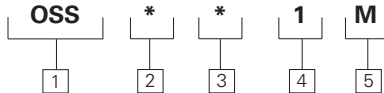

OSS Series Filter and Element Model Code

Sample model code:

OSS3D1M

1 Filter Series - OSS

2 Length

mm (inch)

1 - 109 (4.3)

2 - 142 (5.6)

3 - 203 (8.0)

4 - 277 (10.9)

3 Port Options

B - 3/4" NPT (Length 2 only)

C - 1 1/4" NPT (Length 3 only)

D - 1 1/2" NPT (Length 3,4 only)

E - 3" NPT (Length 5 only)

4 Valve Options

1 - Bypass set at 3 PSI cracking pressure

5 Fluid Cleanliness Rating

Code	Target fluid cleanliness level
M	100m Wire Mesh

In-tank Filters

OSS

Flow Data

Element Flow Data

Housing Dimensions

mm (inch)

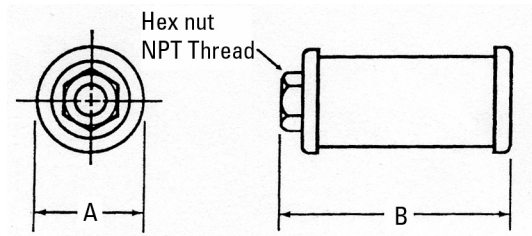

LENGTH	A MM(INCH)	B MM(INCH)	SCREEN AREA (IN ²)
2	68.6 (2.7)	109.2 (4.3)	40
3	86.4(3.4)	142.2(5.6)	128
4	101.6(4.0)	208.2(8.0)	200
5	132.1(5.2)	276.9(10.9)	379

OSS Filter Length 1

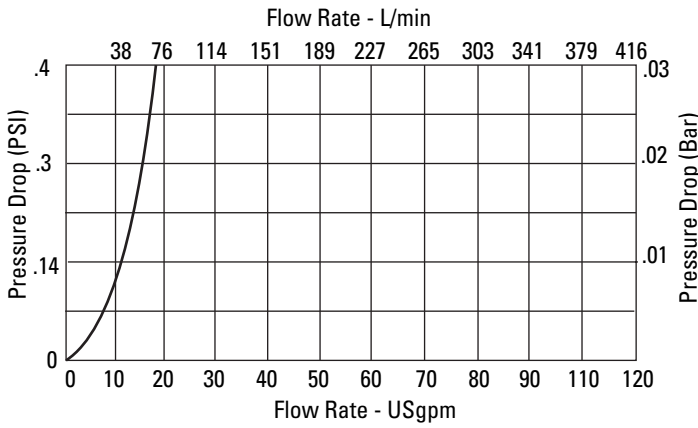

OSS Filter Length 2

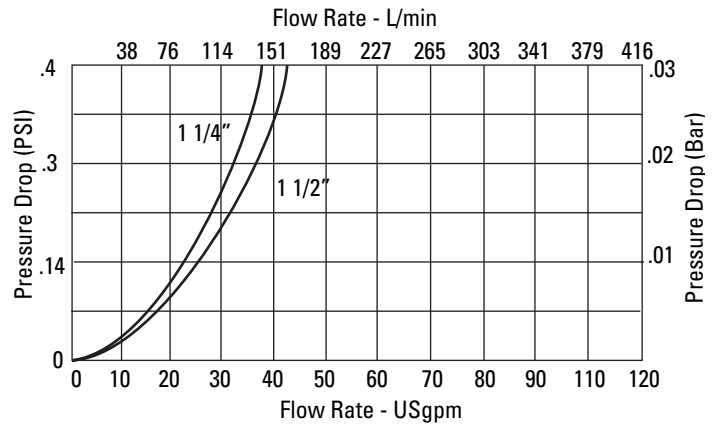

OSS Filter Length 3

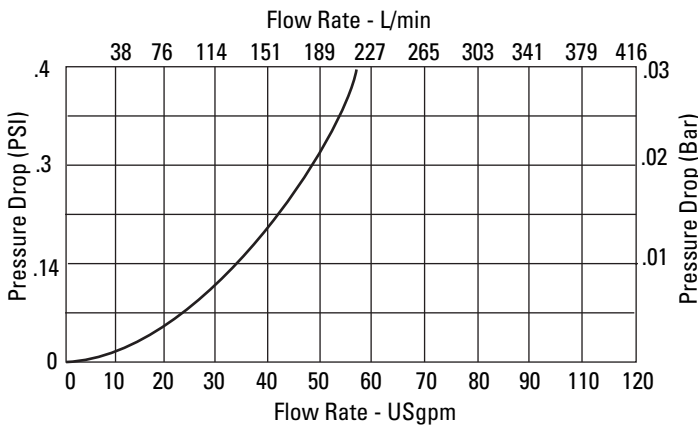

OSS Filter Length 4

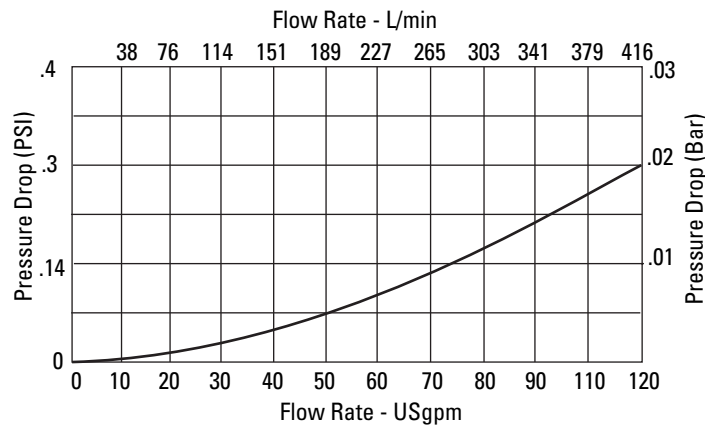

In-tank Filters

Flows to 380 L/min (100 USgpm)

OTM Tank Mounted Strainers

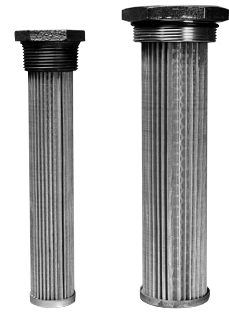

DESIGN SPECIFICATIONS

Rated flow:	See chart below	
Housing and Element Compatibility:	Compatible with all petroleum based fluids, water glycols, synthetic fluids and phosphate ester fluids	
Temp range:	-28 to +100°C (-20 to +210°F)	
Material:	Stainless Steel Cast Iron	
Dry weight: (Approximate with element)	Length 1 Length 2 Length 3 Length 4 Length 5 Length 6	0,1 kg. (0.20 lbs.) 0,2 kg. (0.55 lbs.) 0,3 kg. (0.65 lbs.) 0,5 kg. (1.05 lbs.) 1,0 kg. (2.15 lbs.) 1,8 kg. (4.05 lbs.)

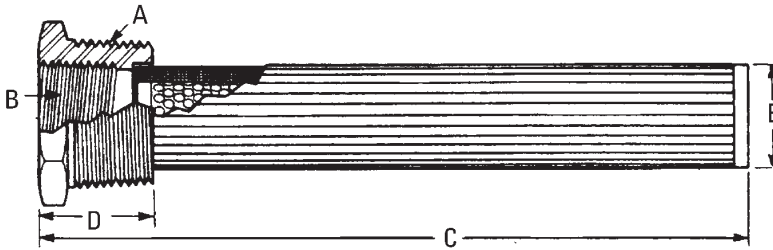

MODEL CODE	A	B	C	D	E	SCREEN AREA	RATED FLOW
						(sq. inch)	(USgpm)
OTM1	1" NPT	1/2" NPT	(5.34)	(1.06)	(1.17)	35	5
OTM2	1 1/4" NPT	3/4" NPT	(8.17)	(1.20)	(1.36)	64	10
OTM3	1 1/2" NPT	1" NPT	(8.20)	(1.22)	(1.66)	86	15
OTM4	2" NPT	1 1/4" NPT	(9.04)	(1.35)	(2.12)	125	25
OTM5	3" NPT	2" NPT	(9.70)	(1.70)	(3.00)	260	50
OTM6	4" NPT	3" NPT	(11.30)	(1.80)	(4.00)	315	100

Items not in bold are non-standard and may have a longer lead time

Indicating Inlet Strainers

General Data

These units have been designed for use in the intake lines of hydraulic pumps to afford a degree of protection from contaminants to the pump and other components in the hydraulic system.

Bypass Valve

An integral relief valve parallels the element and is preset to open at a 2 PSI (standard) or 3 PSI (optional) pressure drop across the element. Element bypassing can be caused by excess flow rates, high fluid viscosity, dirt-loaded elements, or a combination of these.

Air Bleed

These strainers include a standard integral air bleed. It provides faster pump priming on startup and limits the agglomeration of small air bubbles into larger ones. Large air bubbles are detrimental to pump operation.

The unit may be mounted in any position desired. To ensure proper operation of the air bleed feature, however, the inlet port must be pointed down.

Magnets

Magnets are available as an accessory and are installed in the filter on the outside of the element. They act to attract and retain ferrous particles of all sizes, some of which could be small enough to pass through the element mesh and into the pump if no magnets were present.

Indicators

Visual

A highly visible mechanical indicator is linked to the bypass valve. The indicator shows green when the bypass valve is closed and progressively more yellow as a warning when the element pressure drop gets into the danger zone. Red indicates an open bypass valve. The indicator will also automatically show red, (bypass condition) if the unit

is accidentally operated without an element. The visual indicator can also be reassembled to provide a "memory" function. If the protecting hood is removed and the rotary indicator turned 180° on its stem, the unit will indicate the maximum opening of the bypass and remain in that position until reset by rotating the knurled projecting knob.

Electrical

A lever-actuated electric switch is mounted in the indicator enclosure. The switch is depressed by a cam mounted to the bypass valve just prior to the opening of the valve. This changes the completion of the electrical switch circuit from the common and the normally closed terminals to the common and normally open terminals.

Switch actuation will also occur when the unit is accidentally operated without an element.

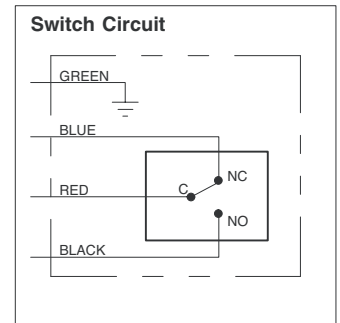

A 1/2" pipe tap is provided for connecting a conduit, and lengths of color coded wires are soldered to the switch terminals for connecting to the external circuit through the conduit wires. The switch contacts are rated for 5 amps resistive loading up to 250V AC.

10F, 50F Series Indicating Inlet Strainers

Flows to 329 L/min (87 USgpm)
Pressure to 0,3 bar (5 PSI) vacuum to 20 bar (300 PSI)
positive



Features and Benefits

- Stainless elements have 149 micron (100 mesh) screen to protect pumps from solid contaminants.
- Available flows to 329 L/min (87 USgpm) on pressure inlets and 254 L/min (67 USgpm) on vacuum inlets.
- Standard integral air bleed feature prevents formation of large bubbles. This provides faster priming of pumps at startup and prevents pump damage.
- Housing can be adapted to handle most hydraulic fluids.
- Large, easy to read, standard visual indicator (or optional electrical indicator) informs operator when element needs to be cleaned.
- Elements can be cleaned and reused.
- Standard bypass valve protects against pump damage.

DESIGN SPECIFICATIONS

Rated flow:	See Table	
Filtration:	Filter is supplied with 149 micron (100 mesh) wire cloth element.	
Fluid compatibility:	Standard model is compatible with most petroleum oil, water glycol, and water-in-oil fluids. Optional seals sand coatings are available for use in phosphate esters and oil-water emulsions. See fluids and seals note in model code.	
Temp range:	-40°C to + 107°C (-40°F to 225°F)	
Pressure rating:	10F and 50F	0,3 bar (5 PSI)
Material:	Cover Housing	Die Cast Aluminum Cast Aluminum
Dry weight:	10F	2,5kg (5.5 lbs)
Approximate	50F	5,7kg (12.5 lbs)

Maximum Flow Ratings

This table presents recommendations for use in both pressurized inlet systems and the more common vacuum inlet systems. The effects of fluid viscosity, specific gravity, and fluid flow rate on the pump inlet system (including the filter) have been taken into consideration. Even with a bypass condition in effect due to element dirt loading, a margin of pump protection is still afforded.

MODEL SERIES	VACUUM INLET*	SPECIAL SERVICE††	PRESSURIZED INLET**	SPECIAL SERVICE††
	NORMAL SERVICE†		NORMAL SERVICE†	
	L/min (USgpm)	L/min (USgpm)	L/min (USgpm)	L/min (USgpm)
10FA	45 (12)	30 (8)	61 (16)	42 (11)
50FB	106 (28)	76 (20)	140 (37)	95 (25)
50FC	178 (47)	125 (33)	257 (68)	167 (44)
50FD	254 (67)	178 (47)	329 (87)	238 (63)

* 0,3 bar (5 PSI) vacuum to 0 bar (0 PSI)

** 0 bar (0 PSI) to 20 bar (300 PSI)

† For use with petroleum oil up to 48 cSt (225 SUS) with less than 457mm (18") lift on vacuum applications.

†† For use with petroleum oils above 48 cSt (225 SUS) and fire resistant fluids.

Model Code

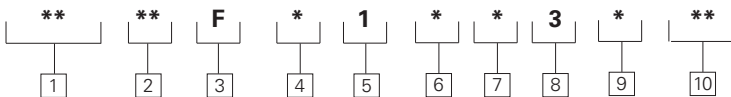

Sample model code:

10FA1SE312

1 Filter Series - ORF

F3 - Special seals
F6 - For oil-in-water emulsions
Blank - Omit if not required
* Use of synthetic, fire-resistant fluids requires filter with special seals. Add prefix F3 to model number when phosphate esters or their blends are to be used. Oil-in-water emulsions require corrosion protection of aluminum parts add prefix F6 when using such fluids. Water glycol, water-in-oil emulsions, and petroleum oil fluids may be used with standard seals.

2 Package Size

10 - 10 size
50 - 50 size

3 Model Series

F - Indicating type inlet filter

4 Port Size

A - 1" (10F)
B - 1½" (50F)
C - 2" (50F)
D - 2½" (50F)

5 Mean Filtration Rating

1 - 149 micron (100 mesh)

6 Port Type

B - G1 (formerly 1" BSPF) thd. (10F only)
F - 4-bolt SAE flange
S - SAE straight thd. in housing (except 50FD)
PF - Inlet: NPTF pipe thd. in housing
Outlet: 4-bolt SAE flange
SF - Inlet: SAE Straight thd. in housing
Outlet: 4-bolt SAE flange

7 Indicator

E - Electrical
L - Less (without) indicator parts
Blank - Omit for mechanical

8 Bypass valve

3 - 3 PSI differential opening pressure
Blank - Omit for 2 PSI differential opening pressure

9 Option

M - Magnets
Blank - Omit if not required

10 Design Number

Subject to change.
Dimensions remain the same for designs 12 and 20.
12 - Mechanical indicator or no indicator
20 - Electrical indicator

Items not in bold are non-standard and may have a longer lead time

10F Series

Indicating Inlet Strainers

10FA Model Series

mm (inch)

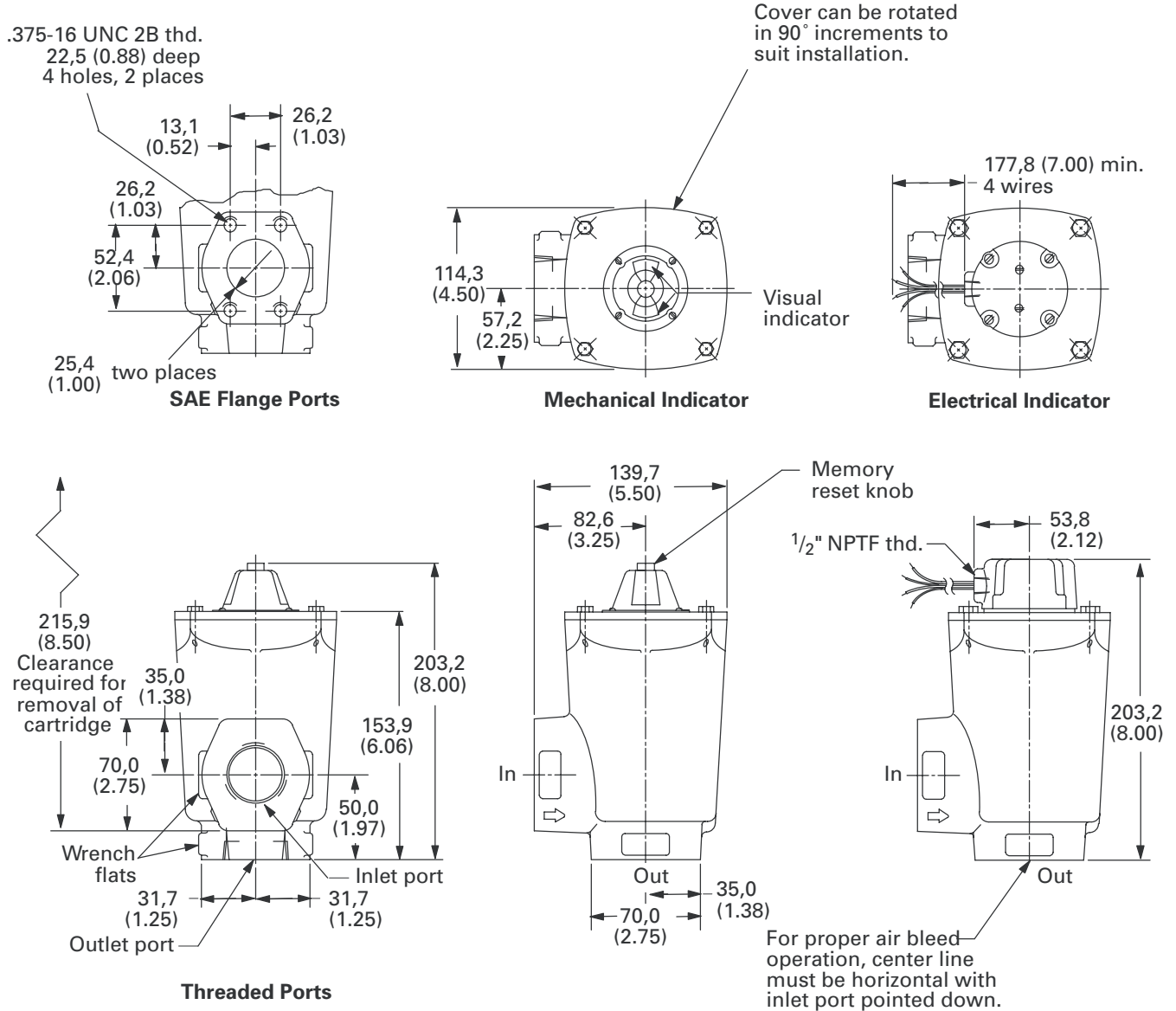

ELEMENT AREA CM ² (IN ²)	INLET AND OUTLET PORT THREADS				
	PIPE THREAD*	SAE STRAIGHT THREAD	TUBE SIZE	NPTF FLANGE*	WELDED FLANGE
419.4 (65)	1" NPTF G1 (1" BSPF)	1.312-12 UN	1.000	FLI-8-08P-10	FLI-8-08W-10

*Not recommended

Items not in bold are non-standard and may have a longer lead time

50F Series

Indicating Inlet Strainers

50F* Model Series

mm (inch)

.500-13 UNC 2B thd.
26,9 (1.06) deep
4 holes, 2 places

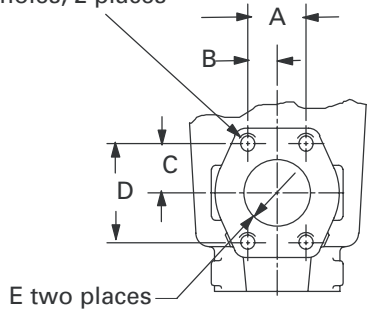

SAE Flange Ports

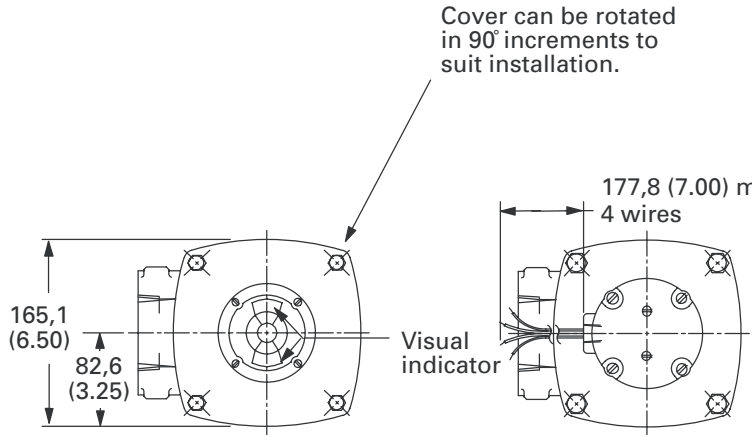

Mechanical Indicator

Electrical Indicator

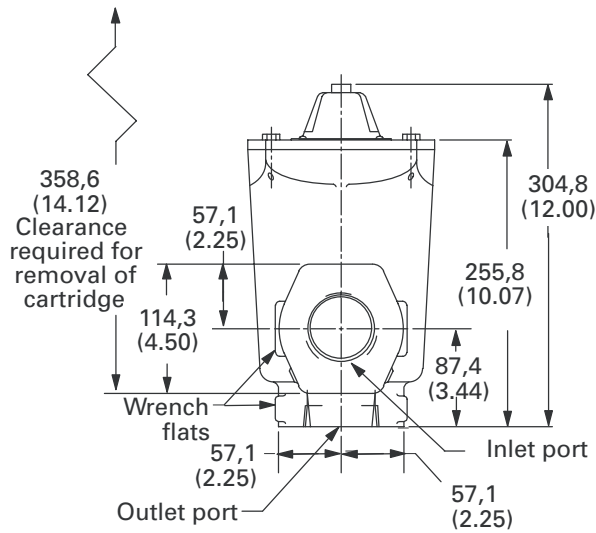

Threaded Ports

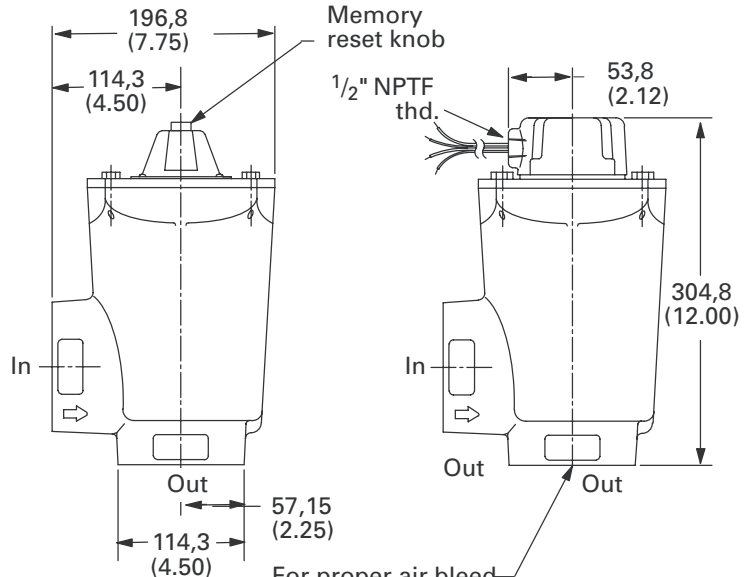

For proper air bleed operation, center line must be horizontal with inlet port pointed down.

MODEL	ELEMENT AREA CM2 (IN2)	INLET AND OUTLET PORT THREADS				SAE FLANGE PORT DIMENSIONS					
		PIPE THREAD*	SAE STRAIGHT THREAD	TUBE SIZE	NPTF FLANGE*	WELDED FLANGE	A	B	C	D	E
50FB	645,2 (100)	1 1/2"	1.875-12 UN	1.50	FLI-12-12P-10	FLI-12-12W-10	35,7 (1.41)	17,8 (0.70)	35,1 (1.38)	69,8 (2.75)	38,1 (1.50)
50FC	1419,4 (220)	2"	2.500-12 UN	2.00	FLI-16-16P-10	FLI-16-16W-10	42,9 (1.68)	21,3 (0.84)	38,9 (1.53)	77,8 (3.06)	50,8 (2.00)
50FD	1419,3 (220)	2 1/2"	-	-	FLI-20-20P-10	FLI-20-20W-10	50,8 (2.00)	25,4 (1.00)	44,4 (1.75)	88,9 (3.50)	63,5 (2.50)

*Not recommended

Items not in bold are non-standard and may have a longer lead time

Spin-on Filters

General Data

Spin-on filters typically consist of a head mounted directly in-line with the return piping and a canister containing an element which screws onto a threaded post. The canister seals to the head to prevent leakage.

These are an effective and economical choice of filter where the return line pressure is low and there are no large flow surges with the return line. They are also easily installed without specialty equipment or tooling.

Applications

- Agricultural equipment - tractors, spreaders, harvesters
- Metal forming presses
- Strapping systems
- Brush Chippers
- Turf maintenance equipment
- Small power units



Items not in bold are non-standard and may have a longer lead time

Spin-on Filters

OFRS15

Flows to 60 L/min (15 USgpm)
Pressures to 7 bar (100 PSI)



Features and Benefits

- Simple spin-on element design for easy maintenance.
- Bypass valves prevent excessive pressure drop and accidental element collapse.
- Two available ports for use as gauge and/or diagnostic ports

DESIGN SPECIFICATIONS

Rated flow:	57 L/min 15 USgpm)	
Fluid compatibility:	Compatible with most most petroleum oil, water glycol, oil-in-water and water-in-oil fluids.	
Temp range:	40°C to +107°C (-40°F to +225°F)	
Pressure rating:	Operating	7 bar (100 PSI)
Material:	Head	Die cast aluminum
	Bowl	Carbon steel
Dry weight:	1,0 kg (2.2 lbs.)	

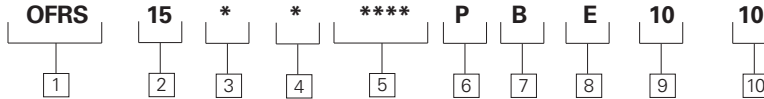

OFRS15 Series Filter and Element Model Code

Sample model code:
OFRS15S2R03PBE1010

1 Filter Series - OFRS

2 Flow Rating

15 -15 USgpm (57 L/min)

3 Port Type

B - G1 (formerly 1" BSPF) thd.

P - 1" NPTF

S - 1.312-12 UN SAE-16 straight thd. for 1" OD tube

4 Assembly Length

mm (inch)

1 - 194,6 (7.7)

2 - 250,4 (9.9)

5 Fluid Cleanliness Rating

Code	Target fluid cleanliness level
R03	16/14/12
R05	18/16/14
R10	20/18/15

6 Pressure Gauge Option

P - Pressure gauge 0-120 PSI (0-8 bar)

Blank - Omit if not required.

7 Inlet Gauge Port Location (1/8" NPTF)

B - Location B

Blank - Omit if not required.

8 Outlet Gauge Port Location (1/8" NPTF)

E - Location E

Blank - Omit if not required.

9 Bypass Valve

10 -Bypass valve set at 10 PSI

Blank - Bypass valve set at 25 PSI

10 Design Number

10 - Standard Design

Spin-on Filters

OFRS15

Flows to 60 L/min (15 USgpm)
Pressures to 7 bar (100 PSI)

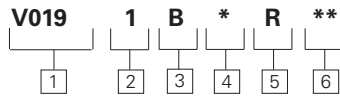

V019 Element Model Code

Sample model code:
V0191B2R03

1 Series Designation

V019 - Filter element for use with OFRS15

2 Element Collapse Rating

1 - 150 PSI

3 Seal Material

B - Buna-N

4 Element Length

mm (inch)
1 - 147 (5.8)
2 - 203 (8.0)

5 Element Construction

R - R-Pak

6 Fluid Cleanliness Rating

Code	Target fluid cleanliness level
03	16/14/12
05	18/16/14
10	20/18/15

Housing Dimensions

mm (inch)

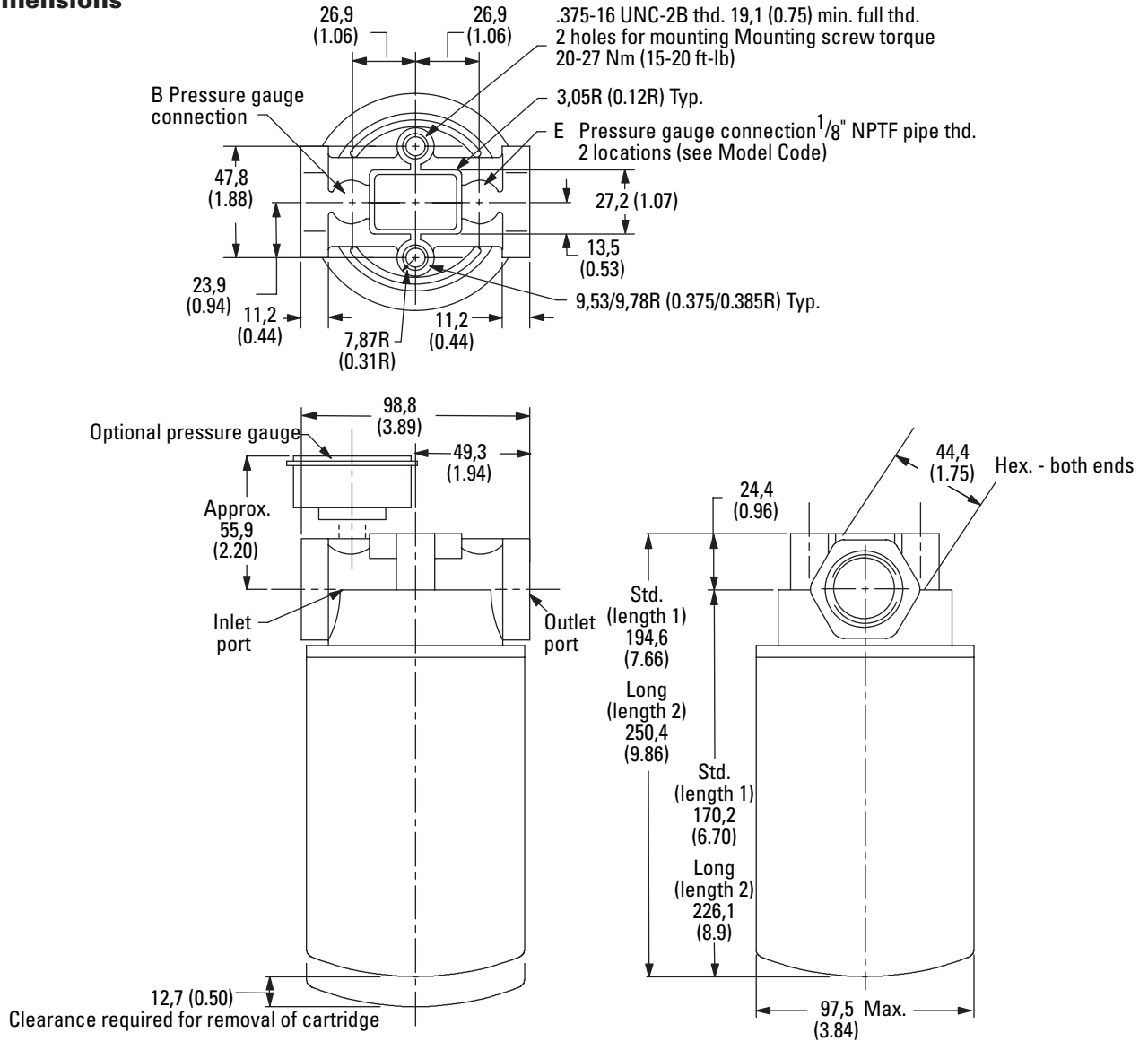

Items not in bold are non-standard and may have a longer lead time

Spin-on Filters

OFRS15

Flow Data

Flows to 60 L/min (15 USgpm)
Pressures to 7 bar (100 PSI)

Flow versus pressure drop:

150 SUS (32 cSt) oil with specific gravity of ≤ 0.9

Element Flow Data

OFRS 15 Element Length 1

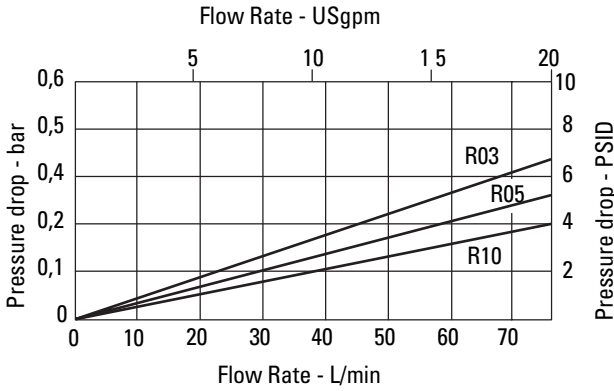

OFRS 15 Element Length 2

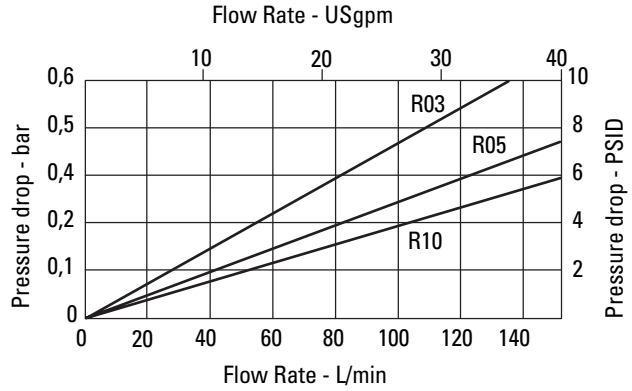

Housing/Bypass Valve Flow Data

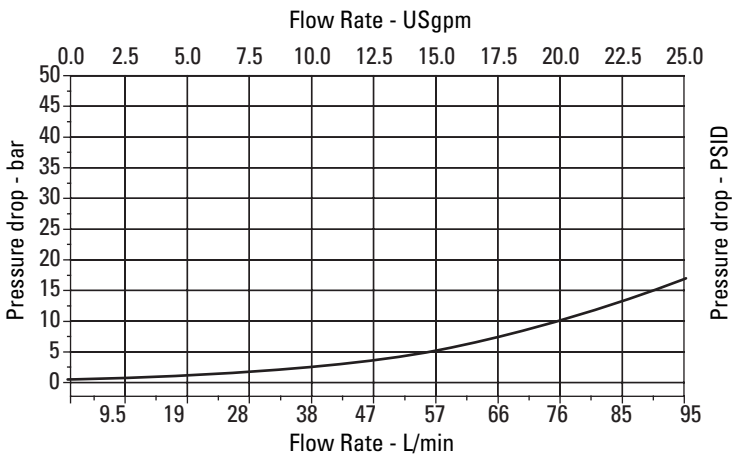

Bypass Valve

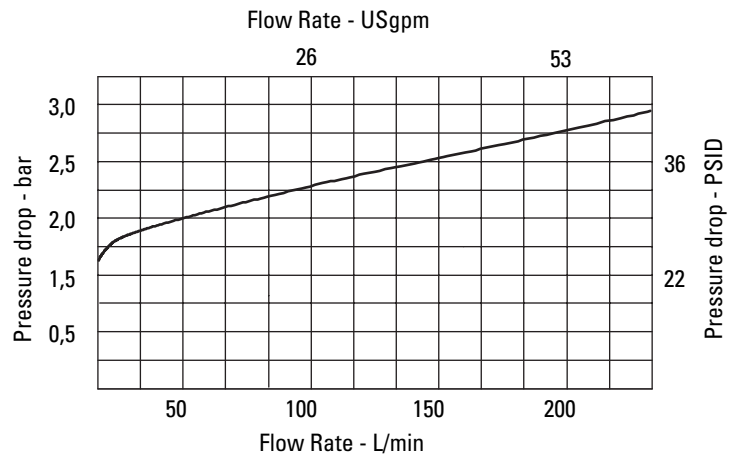

Spin-on Filters

OFRS25

Flows to 95 L/min (25 USgpm)
Pressures to 7 bar (100 PSI)



Features and Benefits

- Simple spin-on element design for easy maintenance.
- Bypass valve prevents excessive pressure drop and accidental element collapse.
- Six available ports for use as gauge and/or diagnostic ports.

DESIGN SPECIFICATIONS

Rated flow:	95 L/min (25 USgpm)	
Fluid compatibility:	Suitable for use with petroleum based, oil-water emulsions, high water based and most water-glycol fluids.	
Temp range:	40°C to +107°C (-40°F to +225°F)	
Pressure rating:	Operating	7 bar (100 PSI)
Material:	Head	Die cast aluminum
	Canister	Carbon steel
Dry weight:	0,9 kg (2.0 lbs)	

OFRS25 Series Filter and Element Model Code

Sample model code:
OFRS25S1R03PAD010

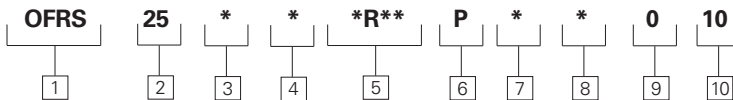

1 Filter Series - OFRS

2 Flow Rating

25 -25 USgpm (95 L/min)

3 Port Type

B - G1 (formerly 1" BSPF) thd.
F - 1" SAE-4-bolt flange code 61
P - 1" NPTF
S - 1.312-12 UN SAE-16 straight thd. for 1" OD tube

4 Assembly Length

mm (inch)
1 - 194,1 (7.6)
2 - 250,4 (9.9)

5 Fluid Cleanliness Rating

Code	Target fluid cleanliness level
R03	16/14/12
R05	18/16/14
R10	20/18/15

6 Pressure Gauge Option

P - Pressure gauge 0-120 PSI (0-8 bar)
Blank - Omit if not required.

7 Inlet Gauge Port Location (1/8" NPTF)

A - Location A
B - Location B
C - Location C
Blank - Omit if not required.

8 Outlet Gauge Port Location (1/8" NPTF)

D - Location D
E - Location E
F - Location F
Blank - Omit if not required.
NOTE: Gauges cannot be mounted side by side. If inlet and outlet gauges are required, specify non-adjacent ports such as A and E.

9 Bypass Valve

0 - Non-bypass
Blank - Bypass valve set at 25 PSI

10 Design Number

10 - Standard Design

Items not in bold are non-standard and may have a longer lead time

Spin-on Filters

OFRS25

Flows to 95 L/min (25 USgpm)
Pressures to 7 bar (100 PSI)

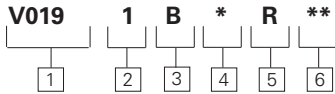

V019 Element Model Code

Sample model code:

V0191B2R03

1 Series Designation

V019 - Filter element for use with OFRS25

2 Element Collapse Rating

1 - 150 PSI

3 Seal Material

B - Buna-N

4 Element Length

mm (inch)

1 - 147 (5.8)

2 - 203 (8.0)

5 Element Construction

R - R-Pak

6 Fluid Cleanliness Rating

Code	Target fluid cleanliness level
03	16/14/12
05	18/16/14
10	20/18/15

Housing Dimensions

mm (inch)

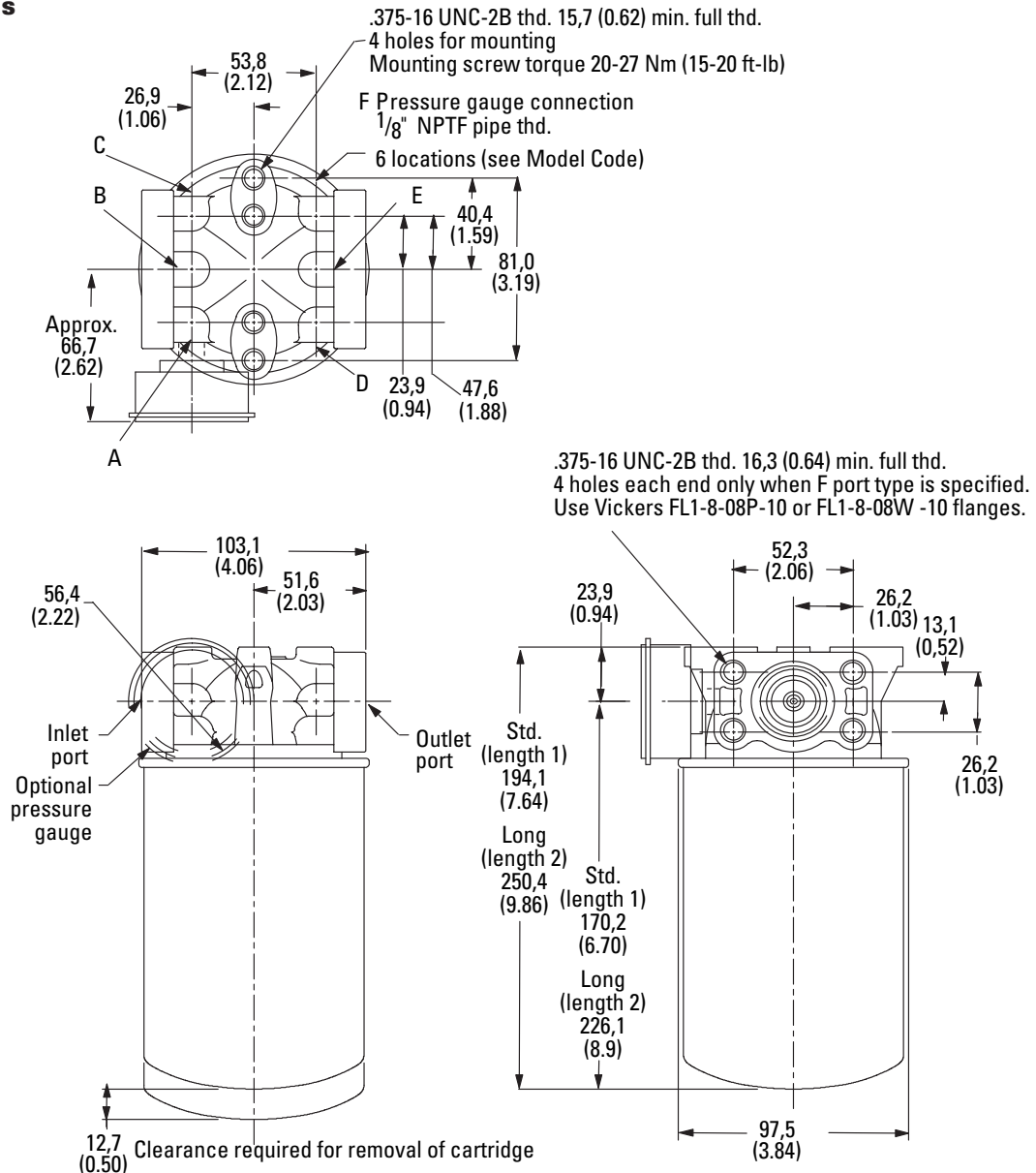

Items not in bold are non-standard and may have a longer lead time

Spin-on Filters

OFRS25

Flow Data

Flows to 95 L/min (25 USgpm)
Pressures to 7 bar (100 PSI)

Flow versus pressure drop:

150 SUS (32 cSt) oil with specific gravity of ≤ 0.9

Element Flow Data

OFRS Element Length 1

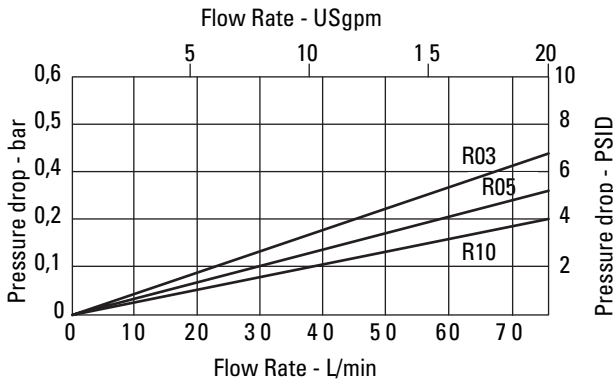

OFRS Element Length 2

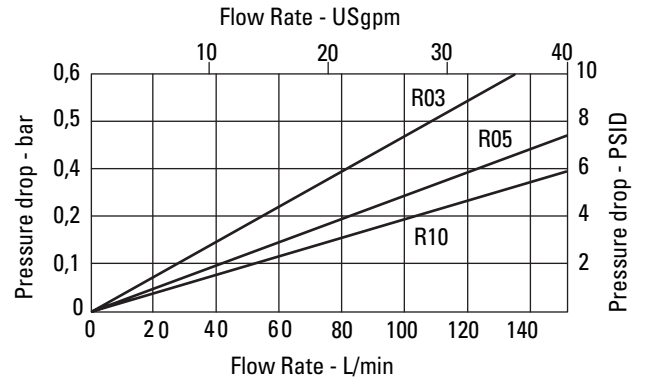

Housing/Bypass Valve Flow Data

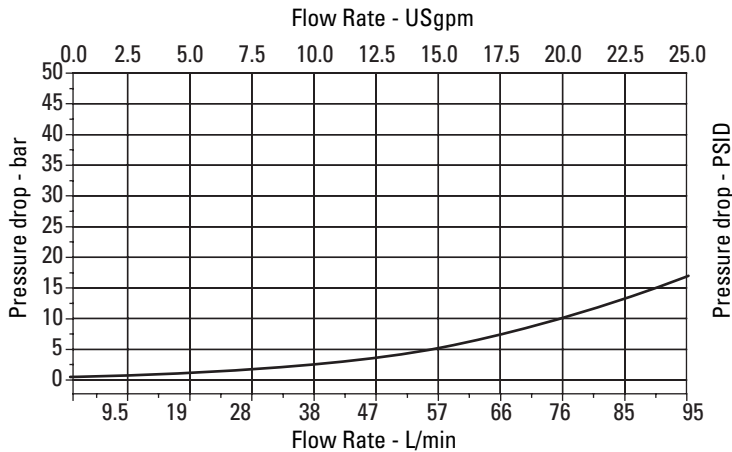

Bypass Valve

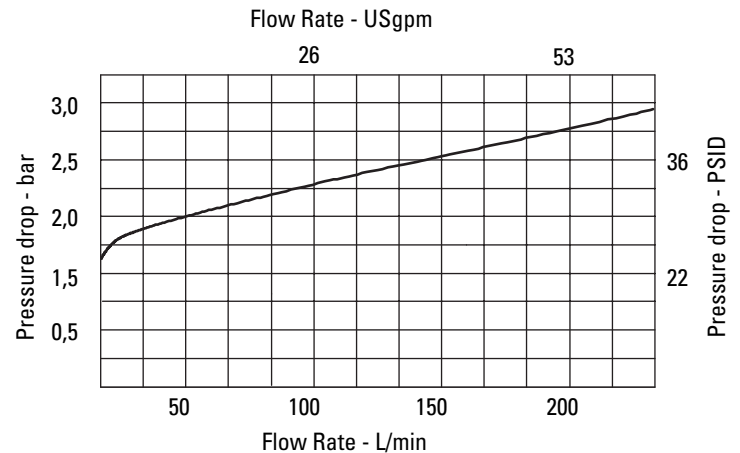

Spin-on Filters

OFSS30

Flows to 115 L/min (30 USgpm)
Pressures to 10 bar (150 PSI)



Features and Benefits

- Simple spin-on element design for easy maintenance.
- Bypass valves prevent excessive pressure drop and accidental element collapse.
- Two available ports for use as gauge and/or diagnostic ports

DESIGN SPECIFICATIONS

Rated flow:	75 L/min (15 USgpm)	
Temp range:	-27°C to +107°C (-20°F to +225°F)	
Pressure rating:	Operating	10 bar (150 PSI)
	Fatigue	20 bar (300 PSI)
Material:	Head	Die cast aluminum
	Bowl	Carbon steel
Dry weight:	1,0 kg (2.2 lbs.)	

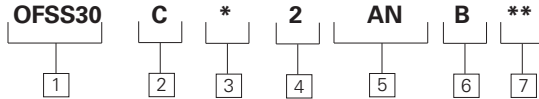

OFSS30 Series Filter and Element Model Code

Sample model code:

OFSS30CE2ANB10

1 Filter Series - OFSS30

2 Element Collapse Rating

C - 100 PSI Low Collapse

3 Port Options

B - 3/4 NPT

E - SAE 12

4 Valve Options

2 - Bypass set at 25 PSI cracking pressure

5 Indicator Options

AN - Visual 0 - 100 PSI, return indicator, color coded

6 Seal Material

B - Buna-N

7 Fluid Cleanliness Rating

Code	Target fluid cleanliness level
05	18/16/14
10	20/18/15
15	Water Removal

05 18/16/14

10 20/18/15

15 Water Removal

Spin-on Filters

OFSS30

Flows to 115 L/min (30 USgpm)
Pressures to 10 bar (150 PSI)

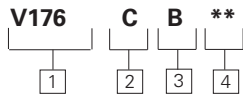

V176 Element Model Code

Sample model code:
V176CB10

1 Series Designation
V176 - For use with OFSS30 spin-ons

3 Seal Material
B - Buna-N

2 Element Collapse Rating
C - 100 PSI Low Collapse

4 Fluid Cleanliness Rating	
Code	Target fluid cleanliness level
05	18/16/14
10	20/18/15
15	Water Removal

Housing Dimensions

mm (inch)

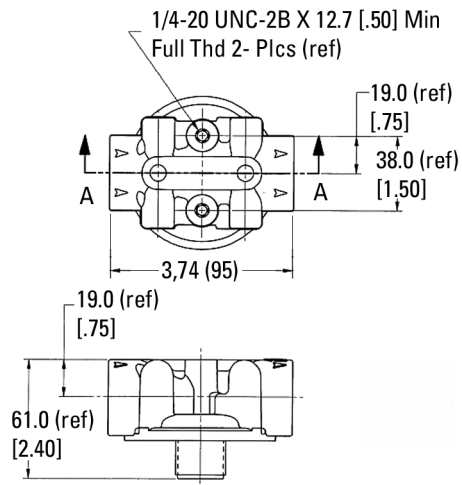
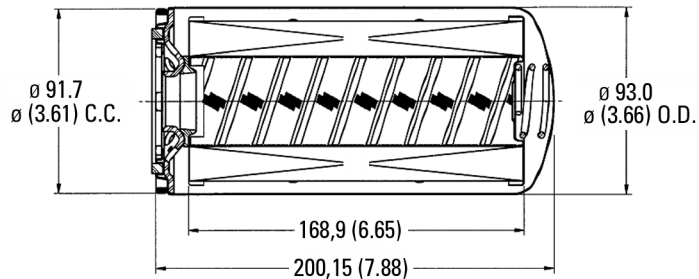
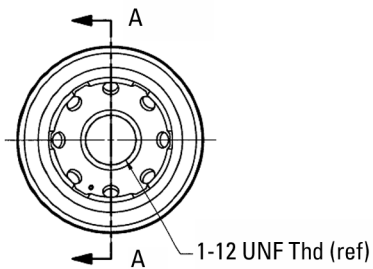

Items not in bold are non-standard and may have a longer lead time

Spin-on Filters

OFRS30

Flow Data

Element Flow Data

OFRS30 5 Micron Element Flow

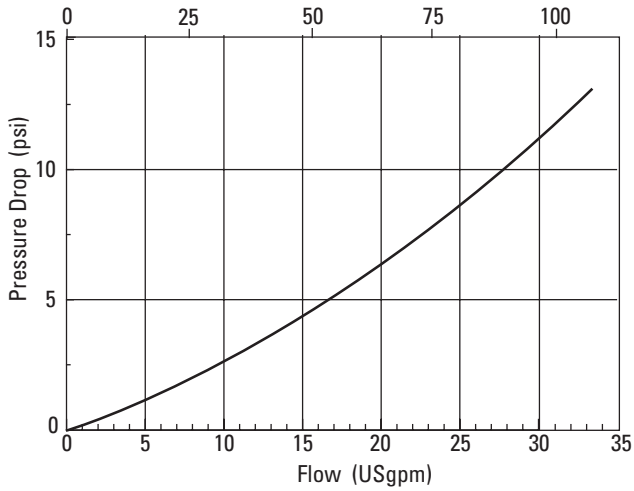

OFRS30 10 Micron Element Flow

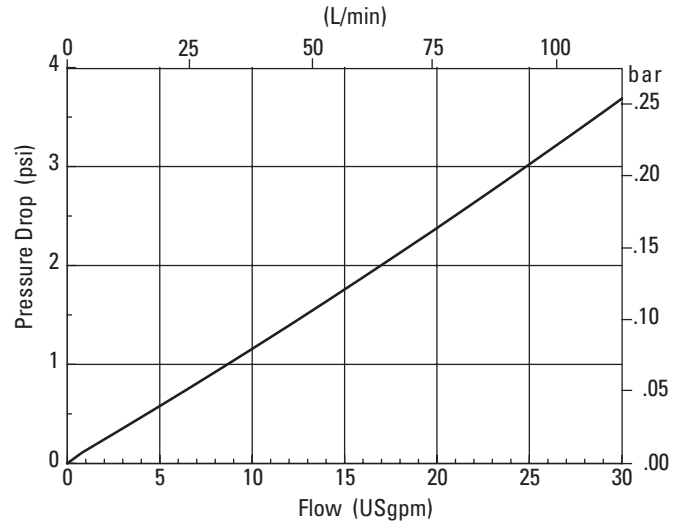

Housing Flow Data

Housing

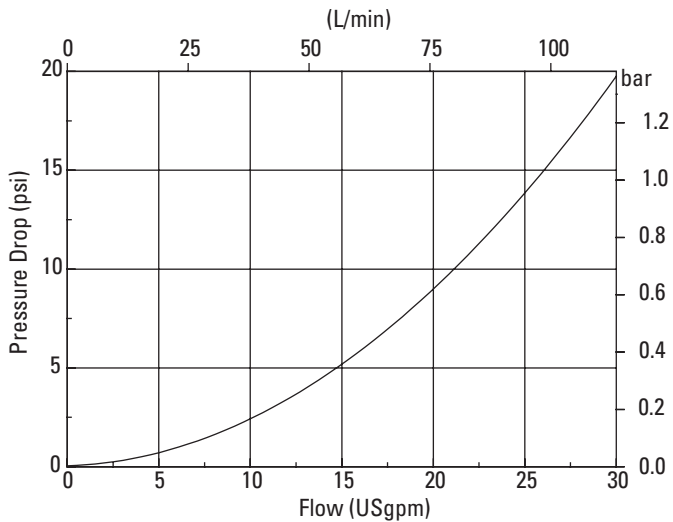

OFRS30 Water Removal Element Flow

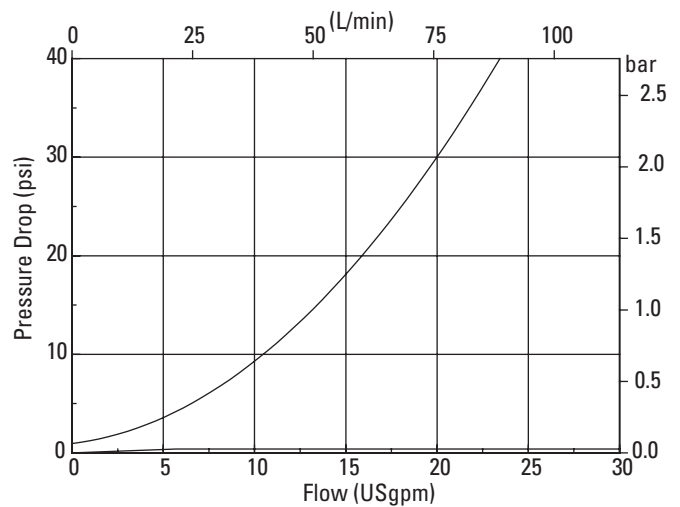

Spin-on Filters

OFRP35 Series

Flows to 130 L/min (35 USgpm)
Pressures to 35 bar (500 PSI)



Features and Benefits

- Ideal for charge pump applications and hydrostatic transmissions.
- Spin-on element design for easy maintenance.
- One port available for use with electric indicator.
- Bypass valves prevent excessive pressure drop and accidental element collapse.

DESIGN SPECIFICATIONS

Rated flow:	130 L/min (35 USgpm)	
Fluid compatibility:	Compatible with most petroleum oil, water glycol, oil-in-water and water-in-oil fluids.	
Temp range:	-29°C to +121°C (-20°F to +250°F)	
Pressure rating:	Operating	35 bar (500 PSI)
	Fatigue	35 bar (500 PSI)
Material:	Head	Die cast aluminum
	Bowl	Steel, cold rolled
Dry weight: (Approximate)	Length 1	1,0 kg (2.2 lbs.)
	Length 2	2,2 kg (4.8 lbs.)

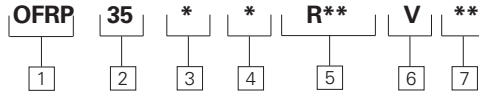

OFRP35 Series Filter and Element Model Code

Sample model code:

OFRP35B2R05V25

1 Filter Series - OFRP

2 Flow rating

35 -35 USgpm (132.5 L/min)

3 Port type

B - 1.062 12 UN SAE-12 (3/4" tube)

P - 1.312 12 UN SAE-16 (1" tube)

S - 1.062 12 UN SAE-12 (3/4" tube) with third port to tank

4 Assembly Length

mm (inch)

1 - 214.9 (8.46)

2 - 303.0 (11.93)

5 Fluid cleanliness rating

Code	Target fluid cleanliness level
R05	14/10/4
R08	18/14/7
R12	19/16/11 (length 2 only)
R18	24/20/15

6 Pressure gauge option

V - Visual indicator left side, blank plate right side, for B and P ports

7 Bypass valve

25 -Bypass valve set at 25 PSI for B and P ports

50 -Bypass valve set at 50 PSI for S port type only

Items not in bold are non-standard and may have a longer lead time

Spin-on Filters

OFRP35 Series

Flows to 130 L/min (35 USgpm)
Pressures to 35 bar (500 PSI)

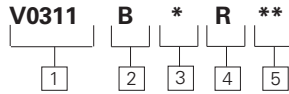

V0311 Element Model Code

Sample model code:

V0311B2R05

1 Filter Element

V0311 - Filter element for use with OFRP35 only

2 Seal material

B - Buna-N

3 Element Length

mm (inch)
1 - 147 (6.0)
2 - 203 (9.4)

4 Element Construction

R - R-Pak

5 Fluid Cleanliness Rating

Code	Target fluid cleanliness level
05	18/16/14
08	19/17/14
12	20/18/15 (length 2 only)
18	22/19/16

Housing Dimensions

mm (inch)

OFRP35 with optional electrical indicator

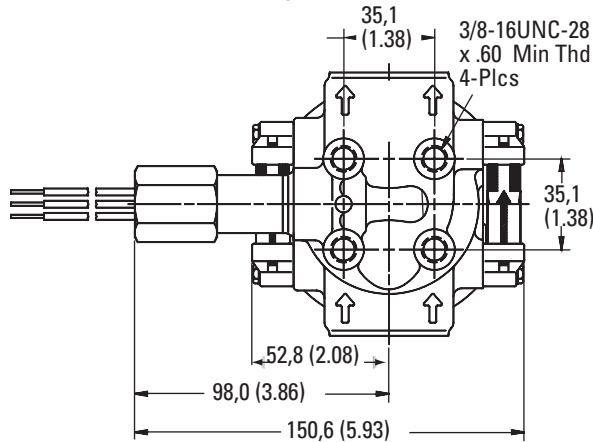

OFRP35 with optional electrical indicator

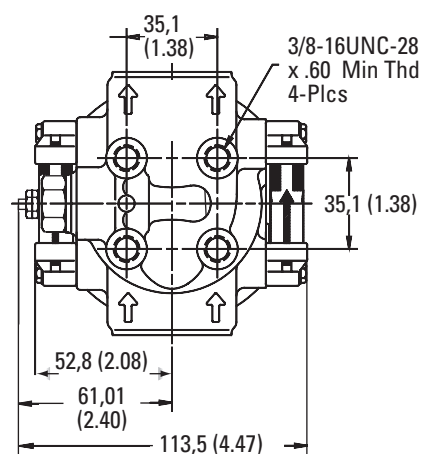

OFRP35 with B1 Length Filter Element

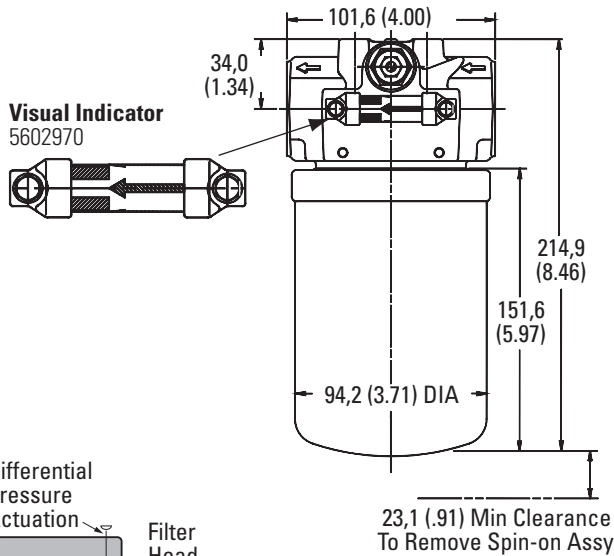

OFRP35 with B2 Length Filter Element

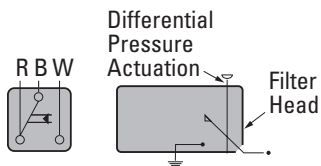
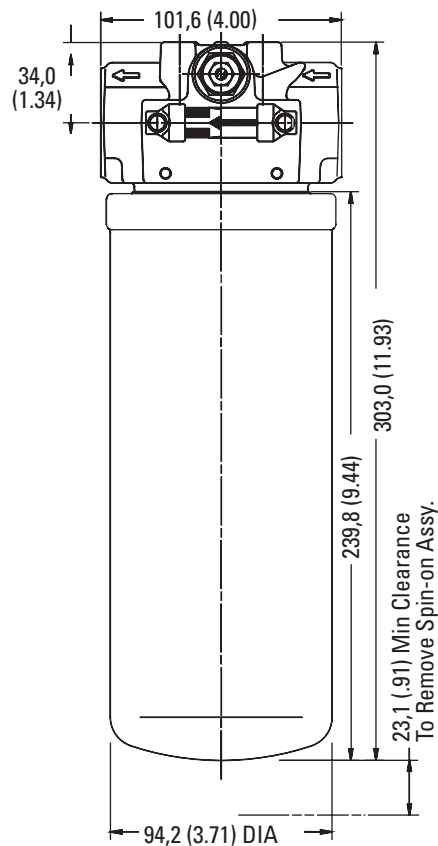

WIRING DIAGRAM FOR ELECTRICAL INDICATORS

5002472	5002471	5002473
3 wire AC/DC	Single post	Single post
2 amps at 24 V DC	6-30 V DC	6-30 V DC
2 amps at 110 V AC		
25 psid	25 psid	50 psid

Items not in bold are non-standard and may have a longer lead time

Spin-on Filters

Flows to 130 L/min (35 USgpm)
Pressures to 35 bar (500 PSI)

OFRP35 Series

Flow Data

Flow versus pressure drop:

150 SUS (32 cSt) oil with specific gravity of ≤ 0.9

Element Flow Data

mm (inch)

OFRP35 R-Pak Element Length 1

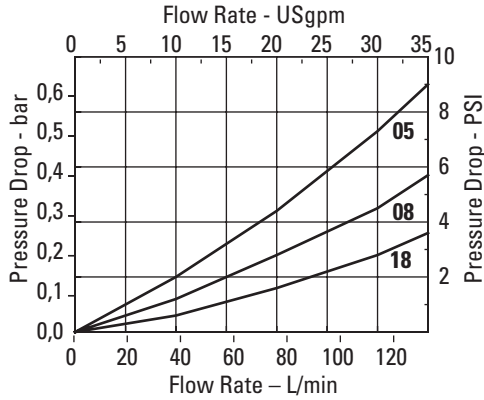

OFRP35 R-Pak Element Length 2

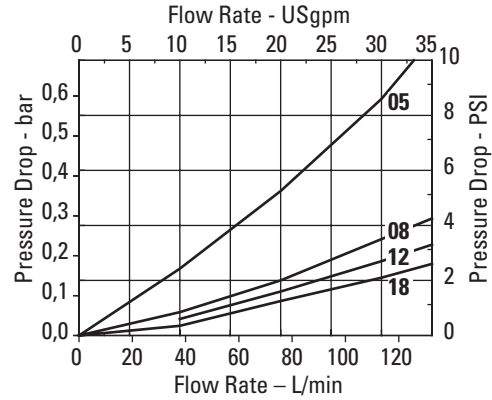

Housing/Bypass Valve Flow Data

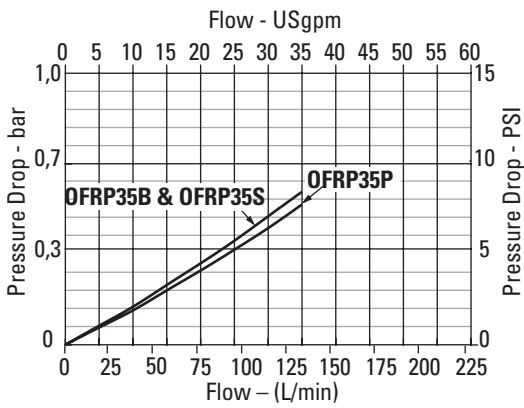

Spin-on Filters

OFRS60 Series

Flows to 227 L/min (60 USgpm)
Pressures to 7 bar (100 PSI)



Features and Benefits

- Available with Vickers proprietary R-Pak media.
- Simple spin-on element design for easy maintenance.
- Optional bypass valves prevent excessive pressure drop and accidental element collapse.
- Six available ports for use as gauge and/or diagnostic ports.
- H2O-Pro Water Removing Element available.

DESIGN SPECIFICATIONS

Rated flow:	227 L/min (60 USgpm)	
Fluid compatibility	Compatible with most petroleum oil, water glycol, oil-in-water and water-in-oil fluids	
Temp range:	40°C to +107°C (-40°F to +225°F)	
Pressure rating:	Operating	7 bar (100 PSI)
Material:	Head	Die cast aluminum
	Canister	Carbon steel
Dry weight:	Length 1	4,4 kg (5.0 lbs)
	Length 2	5,6 kg (6.5 lbs)

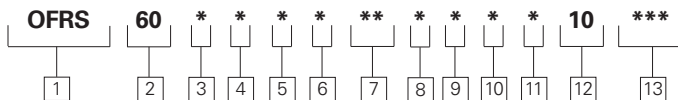

OFRS60 Series Filter and Element Model Code

Sample model code:

OFRS602S1R03PAD010S14

1 Series designation - OFRS

2 Flow rating
60 -60 USgpm (227 L/min)

3 Mounting
2 - Reservoir mount flange (outlet)
Blank - Body or line mounting

4 Port type
B - G1-1/2 (formerly 1/2" BSPF) thd.
F - 1-1/2" SAE 4-bolt flange
P - 1-1/2" NPTF
S - 1.875-12 UN SAE-24 straight thd. for 1-1/2" OD tube

5 Canister Length
mm (inch)
1 - 184 (7)
2 - 286 (11)

6 Element construction
R - R-Pak (grade 3,5,10,20)
W - Water Removal (10)

7 Fluid cleanliness rating
Target fluid cleanliness level Element construction

Code	Target fluid cleanliness level	Element construction
03	16/14/12	R-Pak
05	18/16/14	R-Pak
10	20/18/15	R-Pak
20	22/19/16	R-Pak

10 Water Removal (Length 2 Only)

8 Pressure gauge option
P - Pressure gauge
Blank - Omit if not required

9 Inlet gauge port location (1/8" NPTF)
A - Location A
B - Location B
C - Location C
Blank - Omit if not required

10 Outlet gauge port location (1/8" NPTF)

D - Location D
E - Location E
F - Location F
Blank - Omit if not required
NOTE: Gauges cannot be mounted side by side. If inlet and outlet gauges are required, specify non-adjacent ports such as A and E.

11 Bypass valve
0 - No bypass valve
Blank - Bypass valve set at 25 PSI cracking pressure

12 Design number
10 - Standard Design

13 Special feature suffix
Blank - Omit if not required

Spin-on Filters

OFRS60 Series

Flows to 227 L/min (60 USgpm)
Pressures to 7 bar (100 PSI)

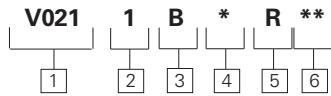

V021 Element Model Code

Sample model code:
VO211B1R03

1 Filter Element

V021 - Filter element for use with H021, H022, H023 and OFRS-60 series filters (R-Pak construction only)

2 Element Collapse Rating

1 - 150 PSI Low Pressure

3 Seal Material

B - Buna-N

4 Canister Length

mm (inch)
1 - 184 (7)
2 - 286 (11)

5 Element Construction

R - R-Pak (grade 3,5,10,20)
W - Water Removal (10)

6 Fluid Cleanliness Rating

Code	Target fluid cleanliness level	Element construction
03	16/14/12	R-Pak
05	18/16/14	R-Pak
10	20/18/15	R-Pak
20	22/19/16	R-Pak
10 Water Removal (Length 2 Only)		

Housing Dimensions

OFRS-60
Body or Line Mounting
mm (inch)

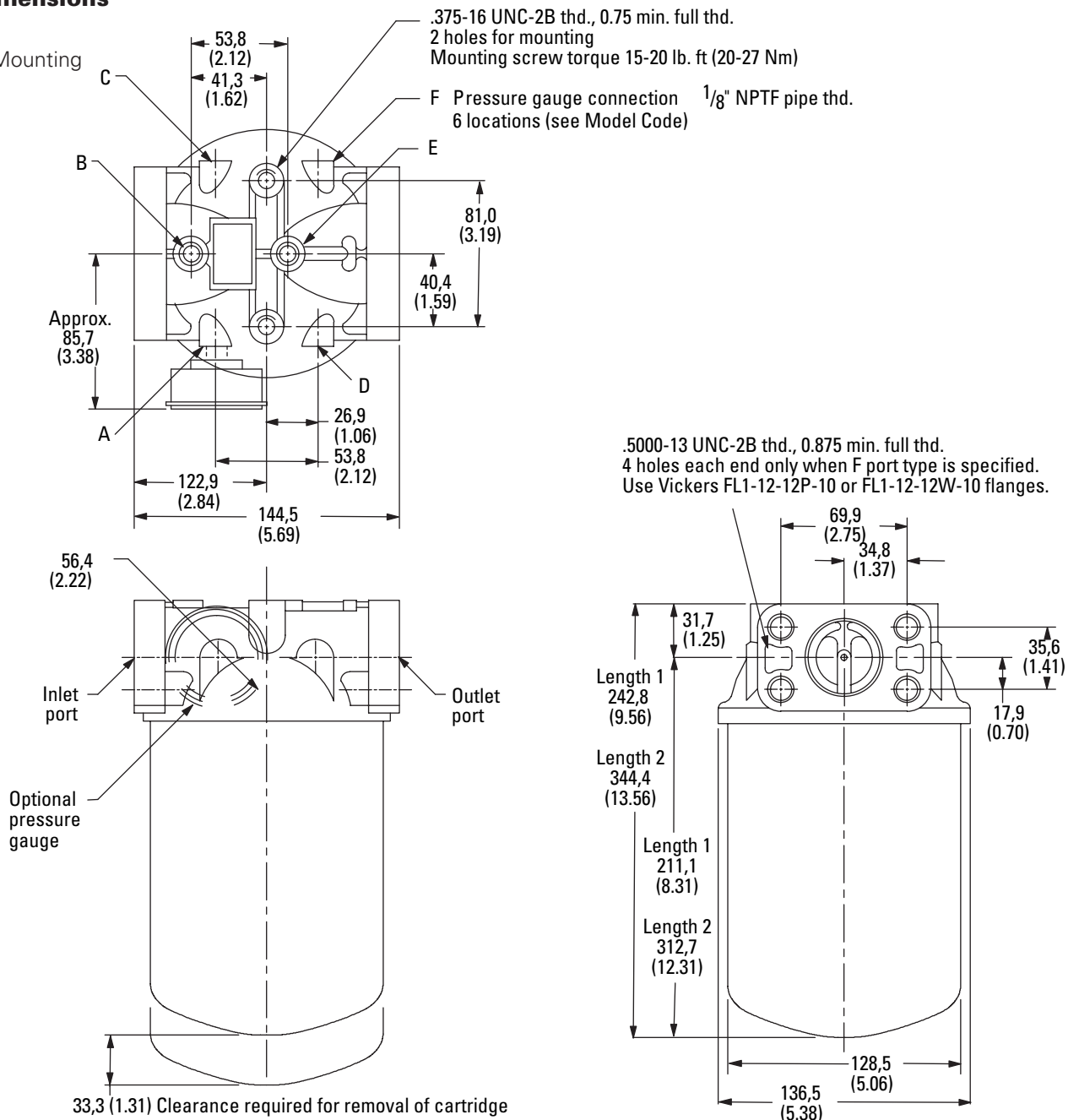

Spin-on Filters

Flows to 227 L/min (60 USgpm)
Pressures to 7 bar (100 PSI)

OFRS60 Series

Housing Dimensions

OFRS-60-2
Manifold Mounting
Outlet Port Connection
mm (inch)

Note:

A, B, C Inlet gauge port locations

D, E, F Outlet gauge port locations

Pressure gauge in locations D and F will require additional fitting to clear mounting bolt hex nuts. Use Aeroquip No. 2040-2-25 or equivalent.

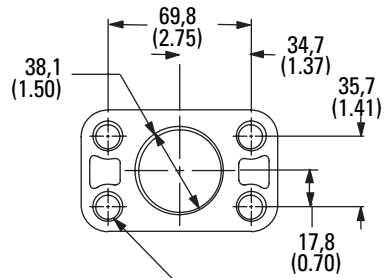
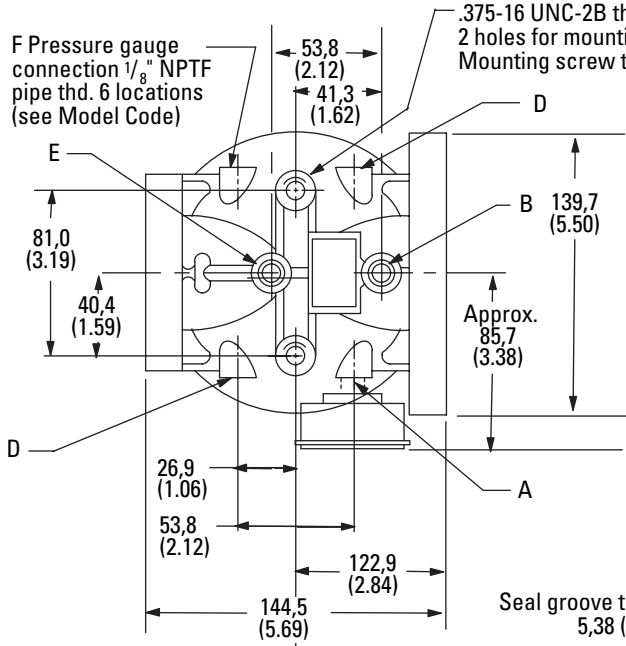

.5000-13 UNC-2B thd., 0.875 min. full thd.
4 holes each end only when F port type is specified.
Use Vickers FL1-12-12P-10 or FL1-12-12W-10 flanges.

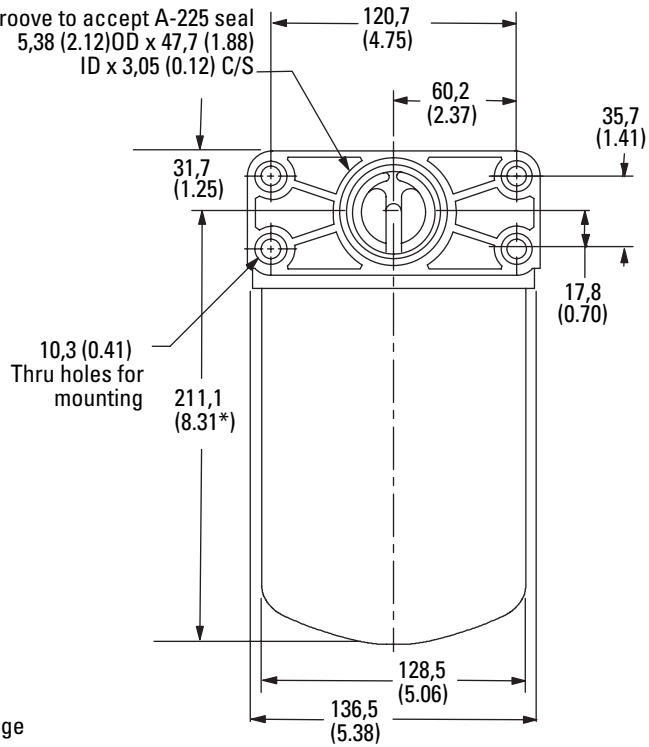
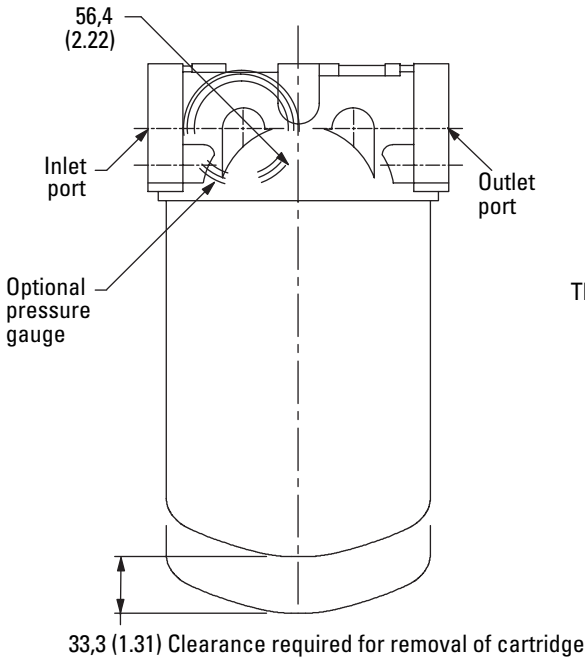

* Add 101,6 (4.00) for long 10mm element.

Spin-on Filters

OFRS60 Series

Flow Data

Flows to 227 L/min (60 USgpm)
Pressures to 7 bar (100 PSI)

Flow versus pressure drop:

150 SUS (32 cSt) oil with specific gravity of ≤ 0.9

Element Flow Data

OFRS60 R-Pak Element Length 1

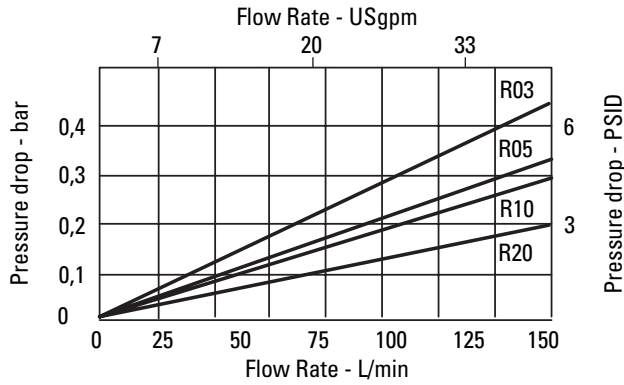

OFRS60 R-Pak Element Length 2

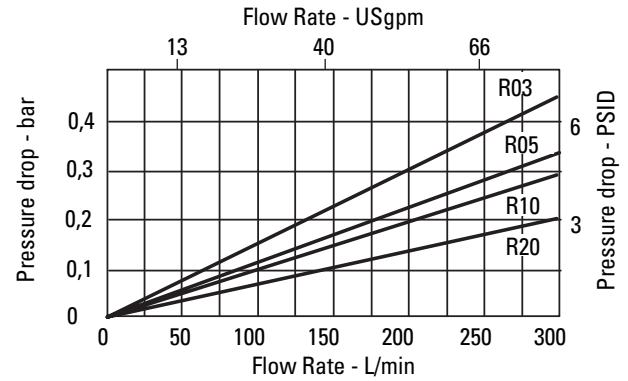

Housing/Bypass Valve Flow Data

Housing Flow Data

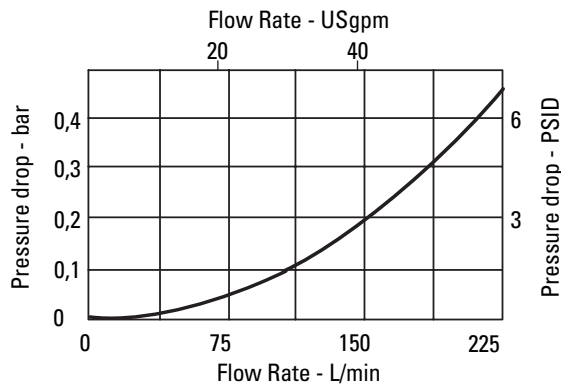

Bypass Valve

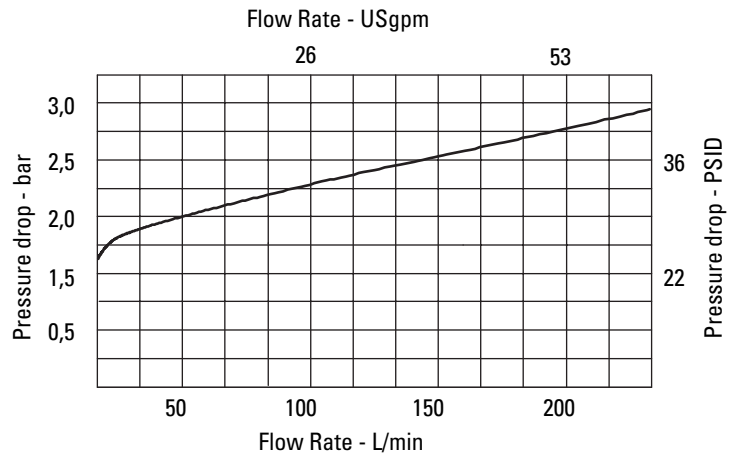

Spin-on Filters

HS22 Series

Flows to 450 L/min (120 USgpm)
Pressures to 14 bar (200 PSI)



Features and Benefits

- Designed to comply with ANSI specifications and ISO cleanliness standards.
- Dual flow path design maximizes flow capability and service life.
- Spin-on element make servicing fast and easy
- High efficiency replacement elements in standard configurations (R-Pak) to meet Target Cleanliness Levels

DESIGN SPECIFICATIONS

Rated flow:	Length 1	227 L/min (60 USgpm)
	Length 2	454 L/min(120 USgpm)
Fluid compatibility	Compatible with most petroleum oil, water glycol, oil-in-water and water-in-oil fluids	
Temp range:	-32°C to +107°C (-25°F to +225°F)	
Pressure rating:	Operating	14 bar (200 PSI)
Material:	Head	Aluminum
Dry weight:	Length 1	7.3 kg (16 lbs)
	Length 2	8.6 kg (19 lbs)

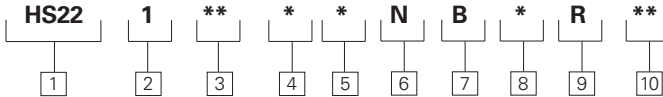

HS22 Series Filter and Element Model Code

Sample model code:
HS221SD32NB2R05

1 Filter Series - HS22

2 Element Collapse Rating

1 - 150 PSI Low Pressure

3 Port options

BD - G1-1/2 to ISO 228

ME - 1-1/2" SAE 4 bolt Flange

Code 61 (M12 x 1.75)

SD - 1.875 - 12 UN sae-24 str. Thd (1-1/2 tube)

FE - 1-1/2" SAE 4 bolt Flange Code 61 (UNC)

4 Valve options

3 - Bypass set at 25 PSI cracking pressure

4 - Bypass set at 50 PSI cracking pressure

5 Indicator options

1 - No indicator

2 - 200 PSI gauge

4 - 60 PSI gauge

6 Receptical

N - None

7 Seal material

B - Buna-N

8 Assembly Length

mm (inch)

1 - 253 (10)

2 - 355 (14)

9 Element construction

R - Standard construction (grade 3, 5, 10, 20)

10 Fluid cleanliness rating

Code **Target fluid cleanliness level**

03 16/14/12 or better

05 18/16/14 or better

10 20/18/15 or better

20 22/19/16 or better

Spin-on Filters

HS22 Series

Flows to 450 L/min (120 USgpm)
Pressures to 14 bar (200 PSI)

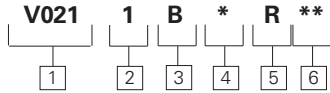

V021 Element Model Code

Sample model code:

VO211B2R05

1 Filter Element

V021 - Filter element for use with HS22 and OFRS-60 series filters (R-Pak construction only)

2 Element collapse rating

1 - 150 PSI Low Pressure

3 Seal material

B - Buna-N

4 Element Length

mm (inch)

1 - 184 (7)

2 - 286 (11)

5 Element construction

R - R-Pak (grade 3,5,10,20)

6 Fluid cleanliness rating

Code	Target fluid cleanliness level	Element construction
03	16/14/12	R-Pak
05	18/16/14	R-Pak
10	20/18/15	R-Pak
20	22/19/16	R-Pak

Housing Dimensions

mm (inch)

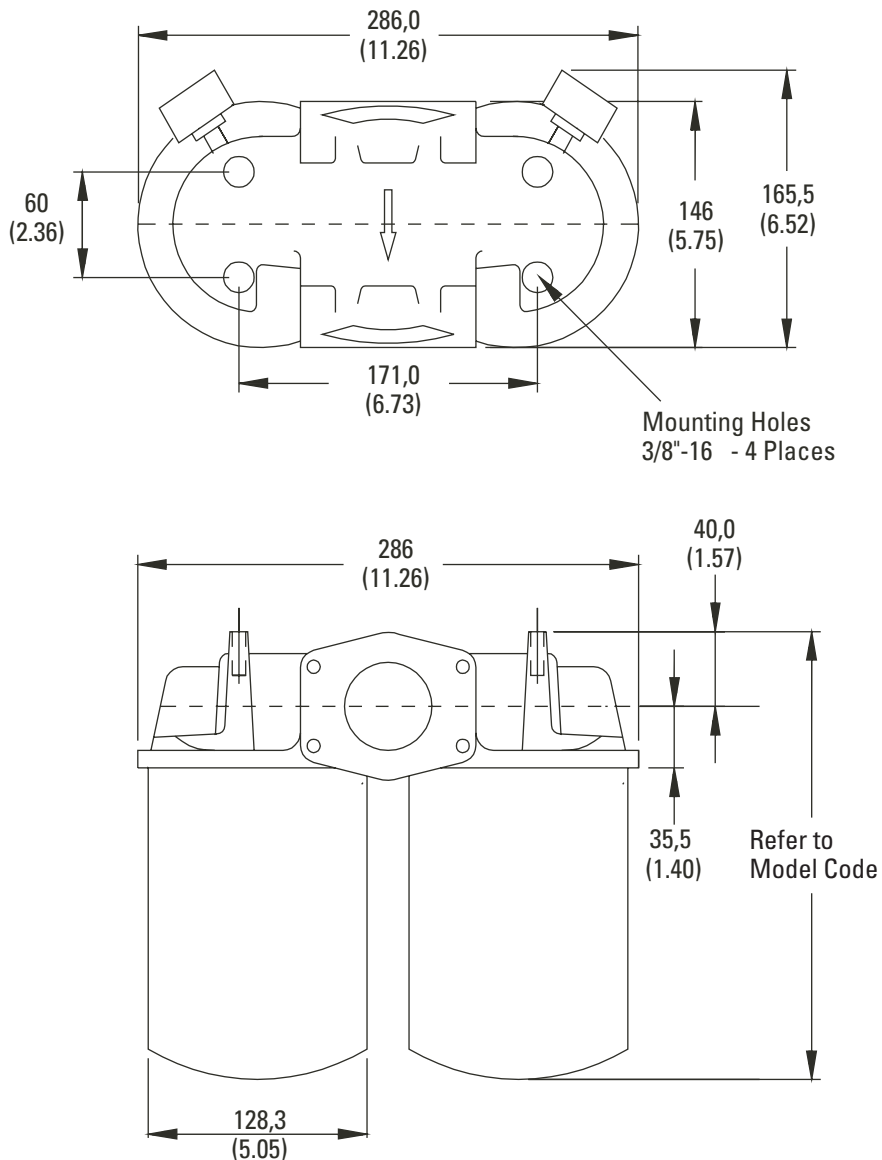

Items not in bold are non-standard and may have a longer lead time

Spin-on Filters

HS22 Series

Flow Data

Flows to 450 L/min (120 USgpm)
Pressures to 14 bar (200 PSI)

Flow versus pressure drop:

150 SUS (32 cSt) oil with specific gravity of ≤ 0.9

Element Flow Data

HS22 R-Pak Element Length 1

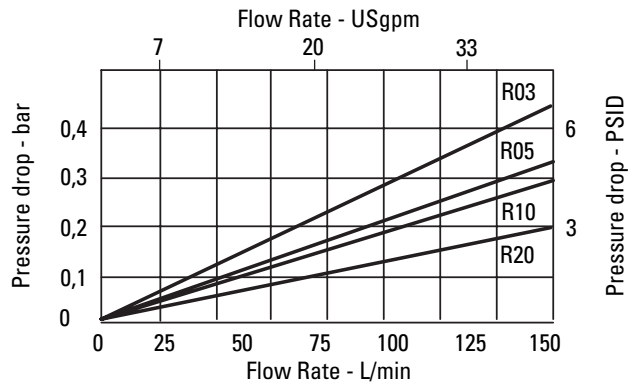

HS22 R-Pak Element Length 2

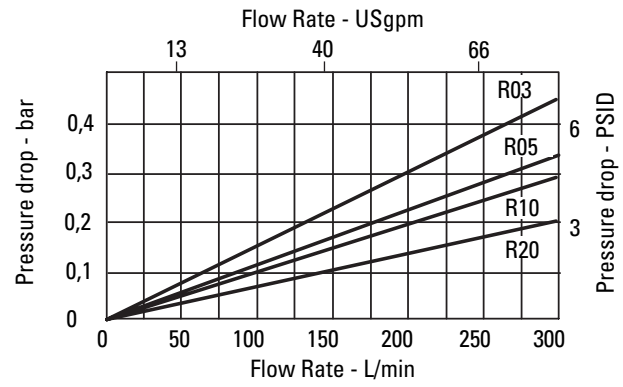

Housing/Bypass Valve Flow Data

Housing

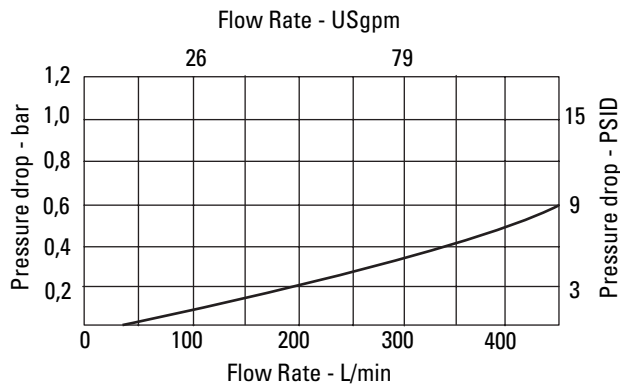

Bypass Valve

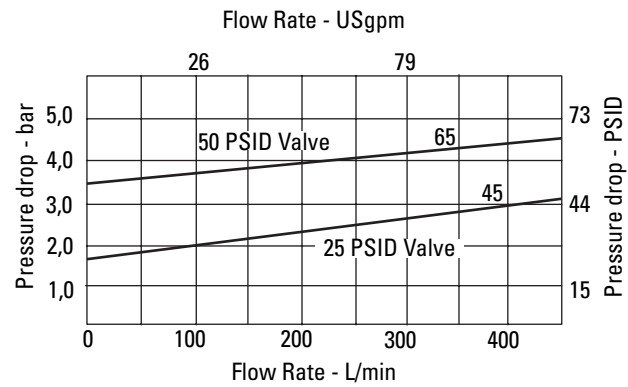

Pressure Filters

General Data

Pressure filters are used to protect downstream components from contamination levels beyond the recommended cleanliness target. Because they are typically sized for the output of the pump, pressure filters tend to be smaller than return line filters when cylinders are

present. In systems using accumulators, pressure filters must be sized according to the large effective flow rates present during parts of the duty cycle.

In some applications, pressure filters are used as isolation filters to protect specific components such as proportional or servo valves. Typically these filters are non-bypass and employ elements that are capable of withstanding full system differential pressure without collapsing. While these filters are sized to handle only a specific components' required flow, the use of high collapse elements result in a higher cost than elements used in housings with bypass valves. Most isolation filters are direct-mounted beneath the valve which can save space as well as reduce plumbing costs.

Applications

- Motion bases
- Sawmill equipment - lathes, kerf saws, optimizers, etc.
- Flight simulators
- Test and simulation equipment
- Entertainment stage equipment
- Hydrostatic drives
- Power generation turbine control systems

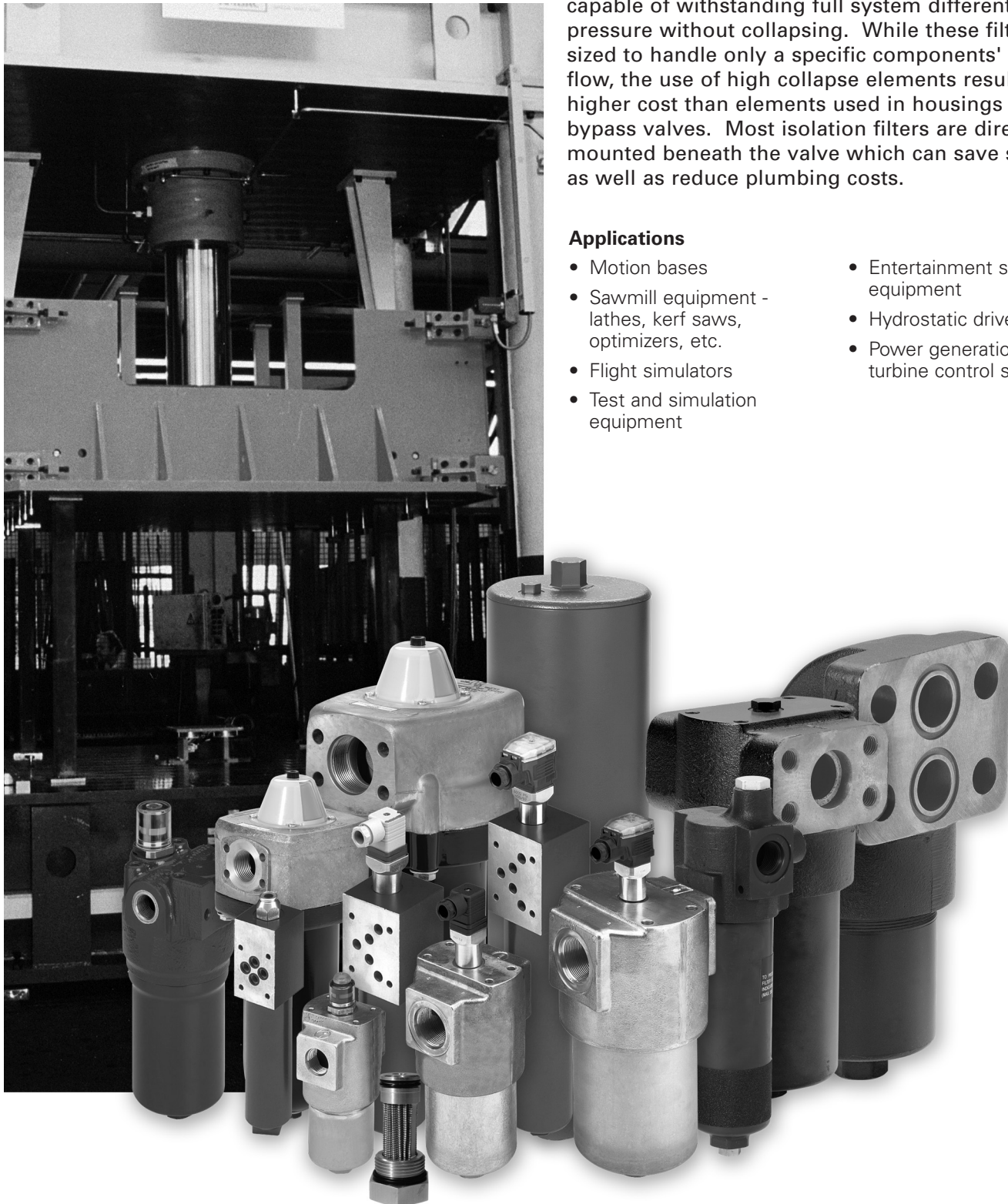

Items not in bold are non-standard and may have a longer lead time

Pressure Filters

ECF Series

Flows to 19 L/min (5 USgpm)
Pressures to 200 bar (3000 PSI)



Features and Benefits

- Integrated throwaway element which is screwed into the manifold port for last chance filtration
- Catches particles in a variety of sizes (20, 50, 70 microns)
- Universally adaptable to all sizes of standard manifolds

DESIGN SPECIFICATIONS

Rated flow:	19 L/min (5 USgpm)	
Fluid compatibility:	Compatible with all petroleum, oil-based and synthetic fluids. Not rated for use with fluoro-rubber or ethylene propylene seals.	
Temp range:	-30°C to +121°C (-22°F to 250°F)	
Pressure rating:	Operating	200 bar (3000 PSI)
Cavity:	BC20-S3	
Material:	Head Bowl	Aluminum Aluminum
Dry weight: (Approximate)	0,11 kg (0.25 lbs)	

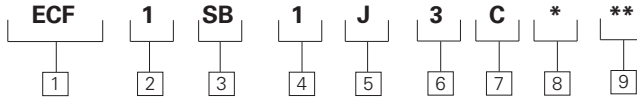

ECF Series Filter and Element Model Code

Sample model code:
ECF1SB1J3CB25

1 Filter Series - ECF

2 Element Collapse Rating

1 - 250 PSI low collapse

3 Port Options

SB - 1.312-12 UN SAE-16
straight thread 1" O.D. tube

4 Valve Options

1 - Non-Bypass
(Screw directly into cavity)

5 Indicator Options

J - No indicator

6 Assembly Length

mm (inch)
3 - 80.2 (3.16)

7 Element Construction

C - Standard construction

8 Seal Material

V - Viton-A

9 Fluid Cleanliness

Code	Fluid Cleanliness Rating	Element construction
15	20/18/15	C-Pak
25		Wirescreen
100		Wirescreen

Pressure Filters

ECF Series

Flows to 19 L/min (5 USgpm)
Pressures to 207 bar (3000 PSI)

Housing Dimensions

mm (inch)

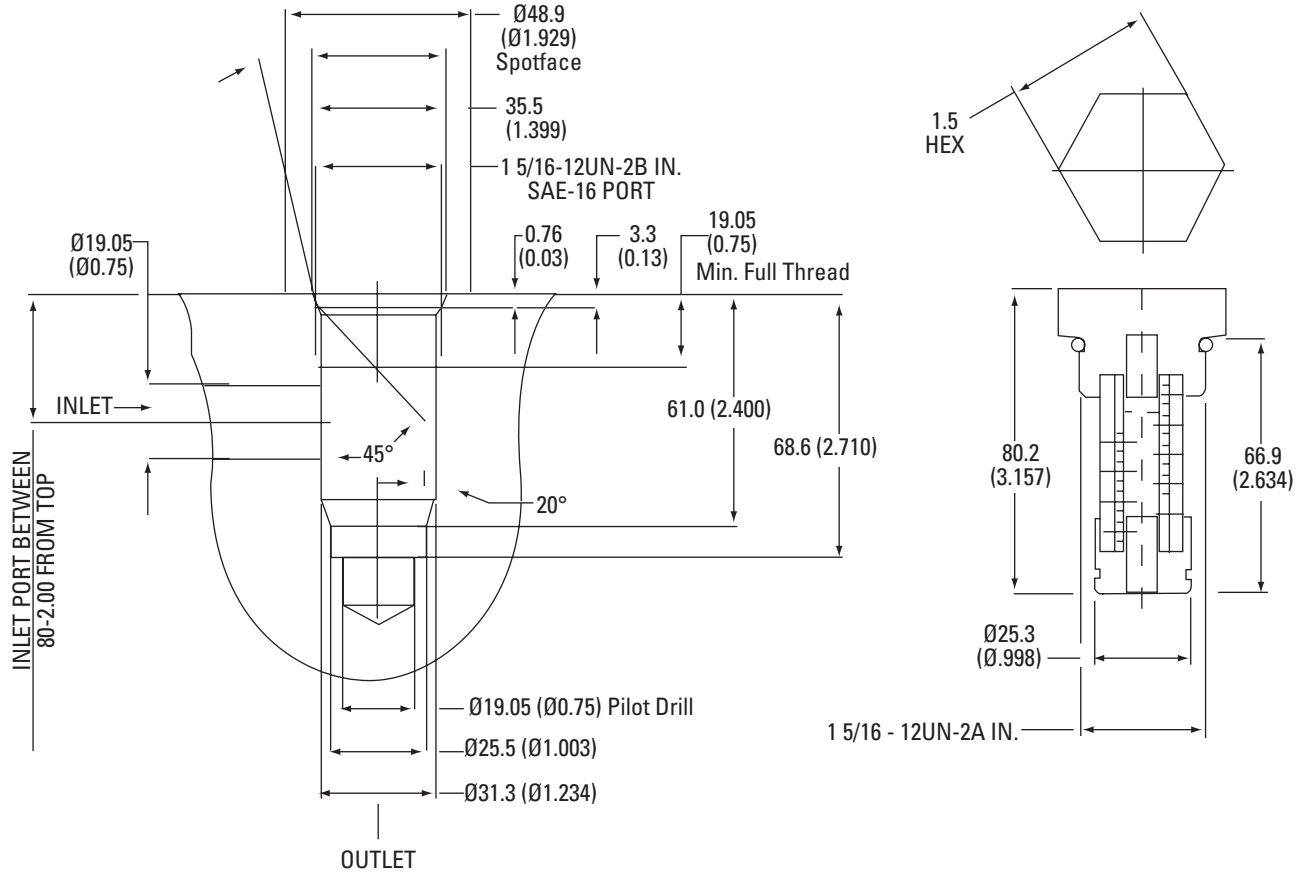

Housing/Element Flow Data

Flow versus pressure drop:

150 SUS (32 cSt) oil with specific gravity of ≤ 0.9

ECF15

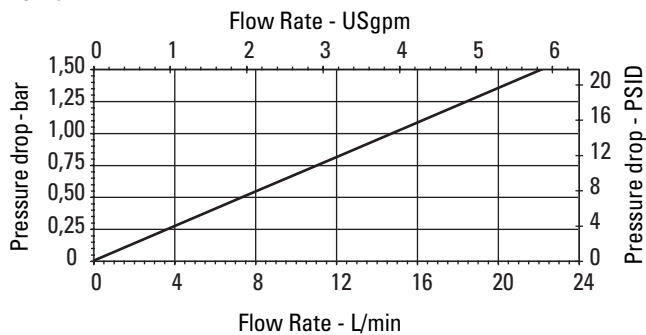

ECF 25/100

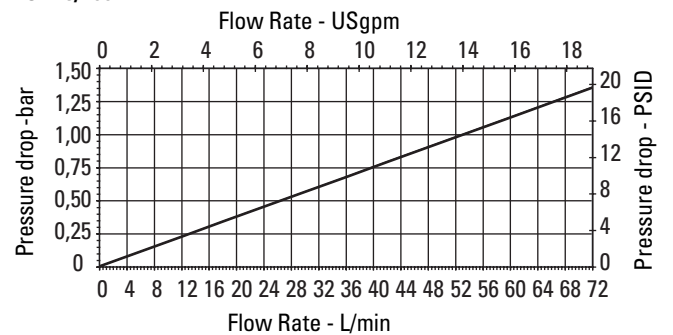

Items not in bold are non-standard and may have a longer lead time

Pressure Filters

LV2P Series

Flows to 110 L/min (29 USgpm)
Pressures to 100 bar (1500 PSI)



Features and Benefits

- Designed to comply with ANSI specifications and ISO cleanliness standards.
- Visual, electrical, and electrical indicators with lamp options for system design flexibility.
- Poppet type by-pass valve construction.
- High efficiency replacement elements in standard configurations (C-Pak) to meet Target Cleanliness Levels.
- High collapse elements available for non-bypass applications.

DESIGN SPECIFICATIONS

Rated flow:	Length 3	60 L/min (16 USgpm)
	Length 6	110 L/min (29 USgpm)
Fluid compatibility:	Compatible with most petroleum oil, oil-in-water and water-in-oil fluids. Optional seals available for phosphate esters.	
Temp range:	-26°C to +121°C (-15°F to +250°F)	
Pressure rating:	Operating	100 bar (1500 PSI)
	Fatigue	100 bar (1500 PSI)
Material:	Head	Aluminum
	Bowl	Aluminum
Dry weight: (Approximate)	Length 3	1,5 kg (3.3 lbs)
	Length 6	1,8 kg (4.0 lbs)

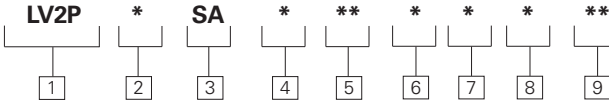

LV2P Series Filter Assembly Model Code

Sample model code:

LV2P1SA4LNB3C05

1 Filter Series - LV2P

2 Element Collapse Rating

- 1** - 250 PSI Low Collapse
- 4** - 1500 PSI High Collapse

3 Port Options

- SA** - 1.062 - 12UN SAE-12 (3/4" tube)

4 Valve Options

- 1** - Non-Bypass
- 4** - Bypass set at 43 PSI cracking pressure
- 6** - Bypass set at 90 PSI cracking pressure

5 Indicator Options

- AN** - Visual 70 PSI, No Connector
- LN** - Visual 30 PSI, No Connector
- JN** - No Indicator (plug), No Connector
- RB** - Electrical 30 PSI, Brad Harrison
- RJ** - Electrical 30 PSI, Hirshman w 24 volt light
- RK** - Electrical 30 PSI, Hirshman w 115 volt light
- RL** - Electrical 30 PSI, Hirshman w 230 volt light
- RH** - Electrical 30 PSI, Hirshman
- UB** - Electrical 70 PSI, Brad Harrison
- UJ** - Electrical 70 PSI, Hirshman w 24 volt light
- UK** - Electrical 70 PSI, Hirshman w 115 volt light
- UL** - Electrical 70 PSI, Hirshman w 230 volt light
- UH** - Electrical 70 PSI, Hirshman

6 Seal Material

- B** - Buna-N
- V** - Viton-A

7 Assembly Length

- mm (inch)
- 3** - 187 (7.36)
- 6** - 254 (10.0)

8 Element Construction

- C** - C-Pak (grade 3, 5, 10, 20)
- H** - H-Pak (grade 3, 5, 10)

9 Fluid Cleanliness Rating

Code	Target fluid cleanliness level
03	16/14/12 or better
05	18/16/14 or better
10	20/18/15 or better
20	22/19/16 or better

Pressure Filters

LV2P Series

Flows to 110 L/min (29 USgpm)
Pressures to 100 bar (1500 PSI)

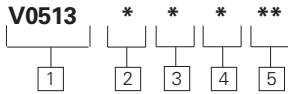

V0513 Element Model Codes

Sample model code:
V0513B6C05

1 Filter Element

V0513 - For use with LV2P series housings

2 Seal Material

B - Buna-N
V - Viton-A

3 Element Length

mm (inch)
3 - 140 (5.51)
6 - 207 (8.15)

4 Element Construction

C - C-Pak (grade 3, 5, 10, 20)
H - H-Pak (grade 3, 5, 10)

5 Fluid Cleanliness Ratings

Code	Target fluid cleanliness level
03	16/14/12 or better
05	18/16/14 or better
10	20/18/15 or better
20	22/19/16 or better

Housing Dimensions

mm (inch)

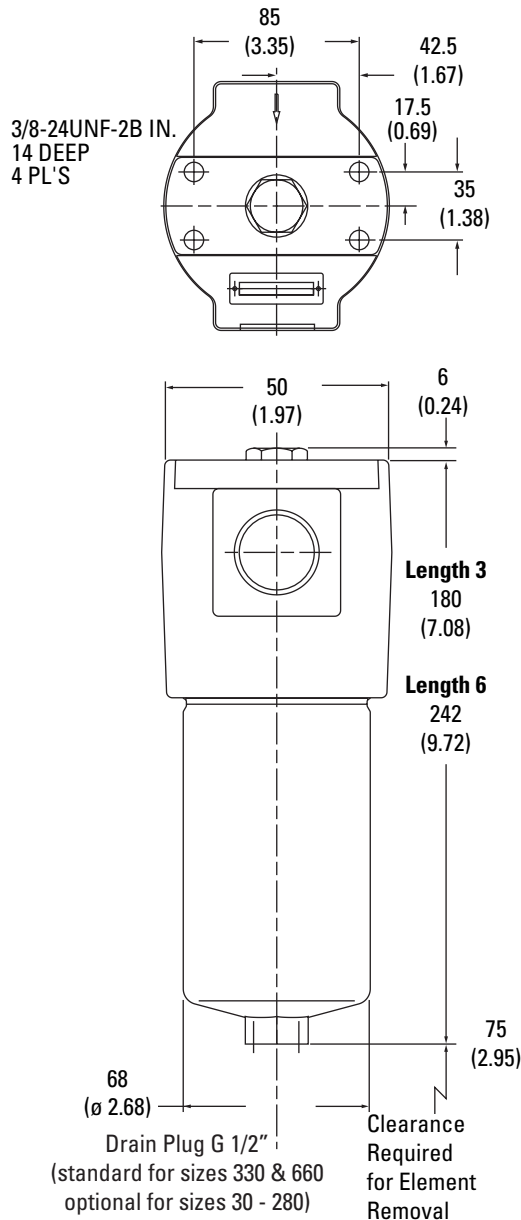

Items not in bold are non-standard and may have a longer lead time

Pressure Filters

Flows to 110 L/min (29 USgpm)
Pressures to 100 bar (1500 PSI)

LV2P Series

Flow Data

Flow versus pressure drop:

150 SUS (32 cSt) oil with specific gravity of ≤ 0.9

Element Flow Data

LV2P C-Pak Element Length 3

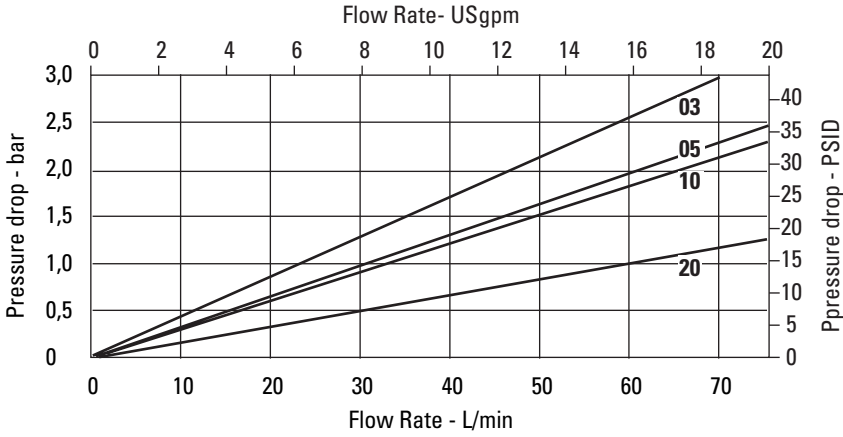

LV2P C-Pak Element Length 6

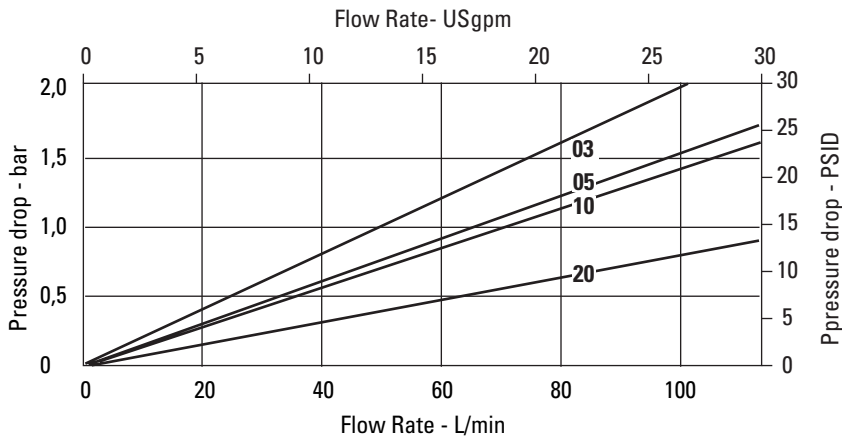

Housing/Bypass Valve Flow Data

Housing

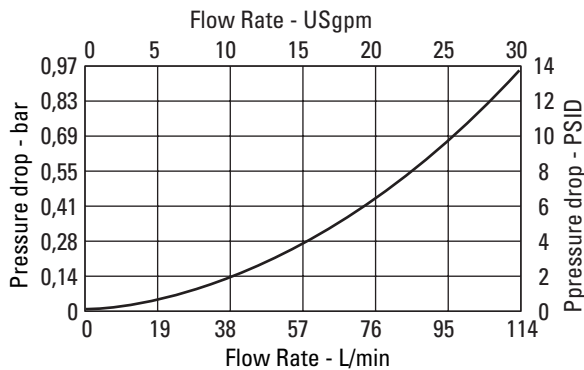

Bypass Valve

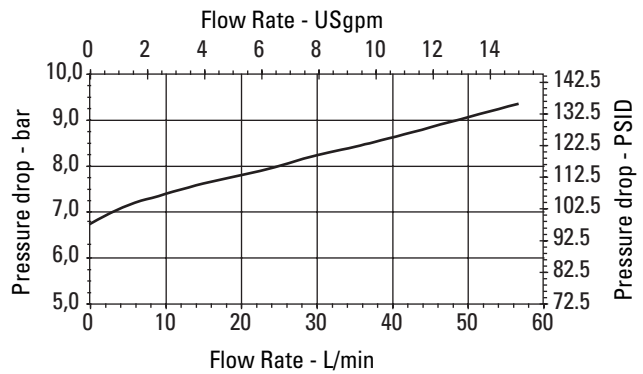

Pressure Filters

LV4P Series

Flows to 330 L/min (87 USgpm)
Pressures to 100 bar (1500 PSI)



Features and Benefits

- Designed to comply with ANSI specifications and ISO cleanliness standards.
- Visual, electrical, and electrical indicators with lamp options for system design flexibility.
- High efficiency replacement elements in standard configurations (C-Pak) to meet Target Cleanliness Levels.
- Poppet type by-pass valve construction.
- High collapse elements available for non-bypass applications.

DESIGN SPECIFICATIONS

Rated flow:	Length 5 Length 7	160 L/min (42 USgpm) 330 L/min (87 USgpm)
Fluid compatibility:	Compatible with most petroleum oil, oil-in-water and water-in-oil fluids. Optional seals available for phosphate esters.	
Temp range:	-40°C to +121°C (-40°F to +250°F)	
Pressure rating:	Operating Fatigue	100 bar (1500 PSI) 100 bar (1500 PSI)
Material:	Head Bowl	Aluminum Aluminum
Dry weight: (Approximate)	Length 5 Length 7	3,7 kg (8.2 lbs) 8,0 kg (17.6 lbs)

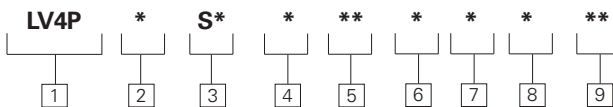

LV4P Series Filter Assembly Model Code

Sample model code:
LV4P1SC4LNB5C05

1 Filter Series - LV4P

2 Element Collapse Rating

- 1** - 250 PSI Low Collapse
- 4** - 1500 PSI High Collapse

3 Port Options

Length 5:

SC - 1.625 - 12UN SAE-20 Str. thd. (1-1/4" tube)

Length 7:

SD - 1.875 - 12UN SAE-24 Str. thd. (1-1/2" tube)

4 Valve Options

- 1** - Non-Bypass
- 4** - Bypass set at 43 PSI cracking pressure
- 6** - Bypass set at 90 PSI cracking pressure

5 Indicator Options

- AN** - Visual 70 PSI, No Connector
- LN** - Visual 30 PSI, No Connector
- JN** - No Indicator (plug), No Connector
- RB** - Electrical 30 PSI, Brad Harrison
- RJ** - Electrical 30 PSI, Hirshman w 24 volt light
- RK** - Electrical 30 PSI, Hirshman w 115 volt light
- RL** - Electrical 30 PSI, Hirshman w 230 volt light
- RH** - Electrical 30 PSI, Hirshman
- UB** - Electrical 70 PSI, Brad Harrison
- UJ** - Electrical 70 PSI, Hirshman w 24 volt light
- UK** - Electrical 70 PSI, Hirshman w 115 volt light
- UL** - Electrical 70 PSI, Hirshman w 230 volt light
- UH** - Electrical 70 PSI, Hirshman

6 Seal Material

- B** - Buna-N
- V** - Viton-A

7 Assembly Length

- mm (inch)
- 5** - 247 (9.73)
- 7** - 312 (12.29)

8 Element Construction

- C** - C-Pak (grade 3, 5, 10, 20)
- H** - H-Pak (grade 3, 5, 10)

9 Fluid Cleanliness Rating

Code	Target fluid cleanliness level
03	16/14/12 or better
05	18/16/14 or better
10	20/18/15 or better
20	22/19/16 or better

Items not in bold are non-standard and may have a longer lead time

Pressure Filters

LV4P Series

Flows to 330 L/min (87 USgpm)
Pressures to 100 bar (1500 PSI)

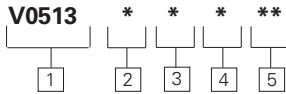

V0513 Element Model Codes

Sample model code:

V0513B5C05

1 Filter Element
V0513 - For use with LV4P series housings

2 Seal Material

B - Buna-N
V - Viton-A

3 Element Length

mm (inch)
5 - 147 (5.8)
7 - 180 (7.09)

4 Element Construction

C - C-Pak (grade 3, 5, 10, 20)
H - H-Pak (grade 3, 5, 10)

Fluid Cleanliness Rating

Code	Target fluid cleanliness level
03	16/14/12 or better
05	18/16/14 or better
10	20/18/15 or better
20	22/19/16 or better

Housing Dimensions

mm (inch)

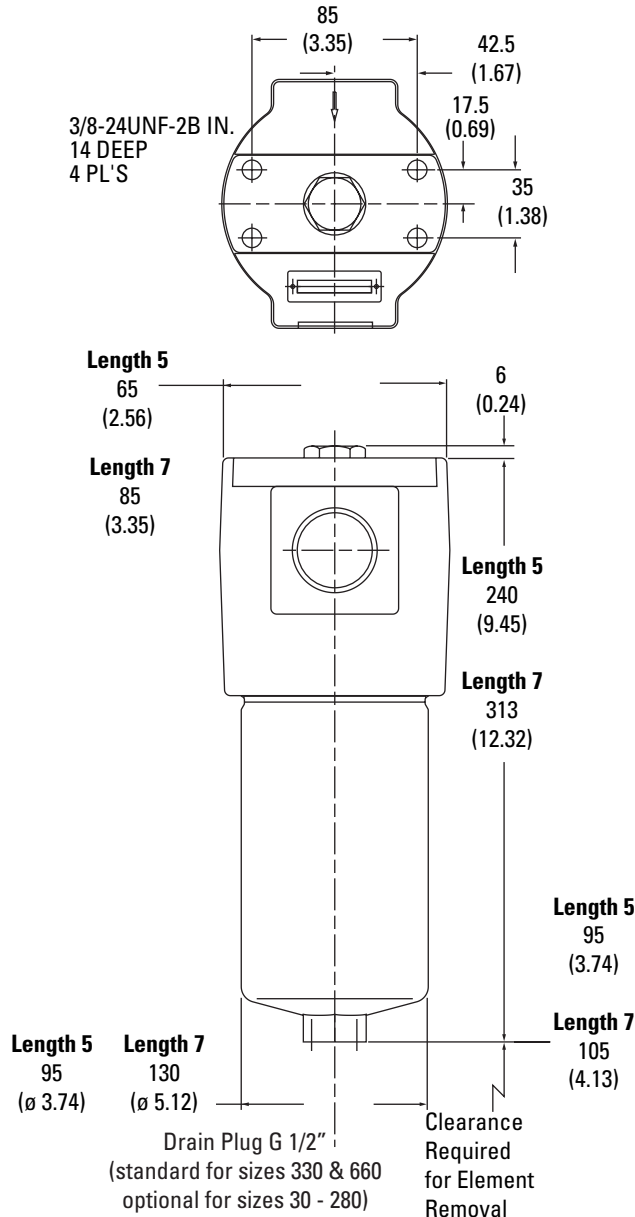

Items not in bold are non-standard and may have

Pressure Filters

Flows to 330 L/min (87 USgpm)
Pressures to 100 bar (1500 PSI)

LV4P Series

Flow Data

Flow versus pressure drop:

150 SUS (32 cSt) oil with specific gravity of ≤ 0.9

Element Flow Data

LV4P C-Pak Element Length 5

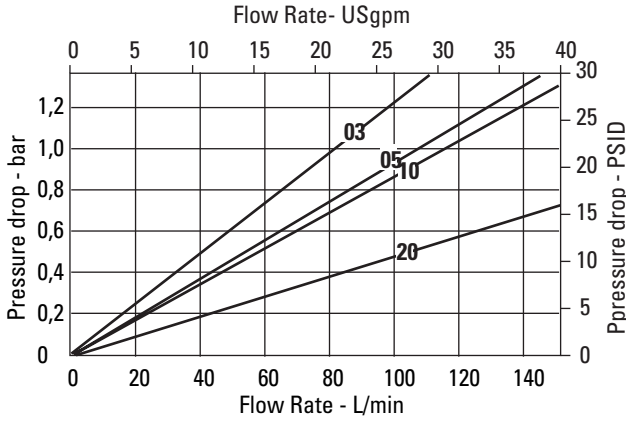

LV4P C-Pak Element Length 7

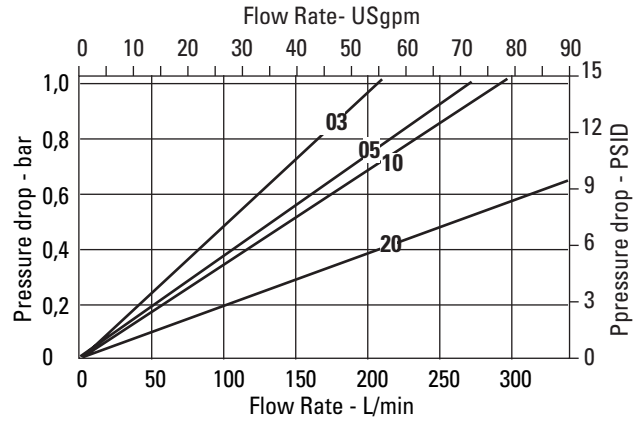

Housing/Bypass Valve Flow Data

Length 5 Housing

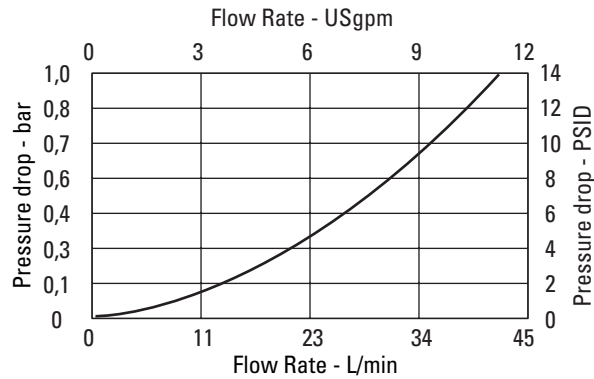

Length 5 Bypass

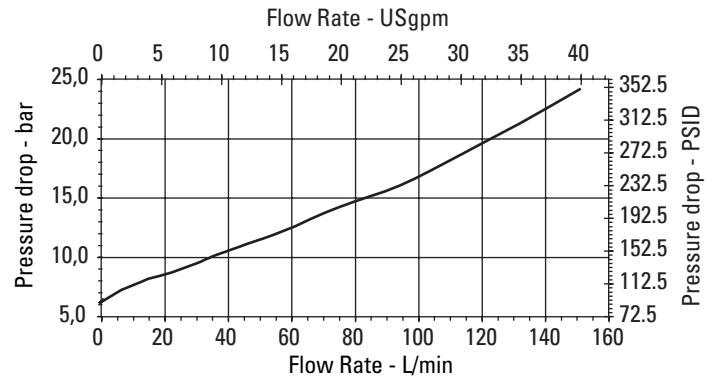

Length 7 Housing

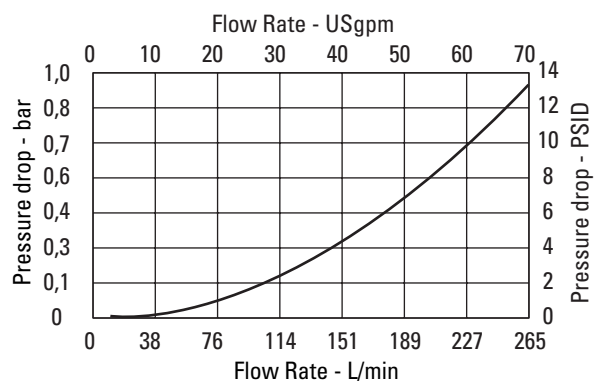

Length 7 Bypass

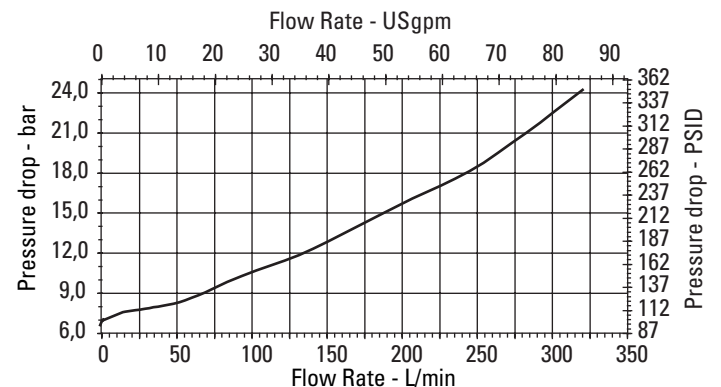

Items not in bold are non-standard and may have a longer lead time

Pressure Filters

HF2P Series

Flows to 90 L/min (24 USgpm)
Pressures to 280 bar (4000 PSI)



Features and Benefits

- Designed to comply with ANSI specifications and ISO cleanliness standards.
- Visual, electrical, and electrical indicators with lamp options for system design flexibility
- Conforms to HF2 automotive specifications
- Compact design for use with servo and proportional valves
- Manifold mounting option for system flexibility
- High efficiency replacement elements in standard configurations (C-Pak) to meet Target Cleanliness Levels
- High collapse elements available for non-bypass applications.

DESIGN SPECIFICATIONS

Rated flow:	Length 1	45 L/min (12 USgpm)
	Length 2	91 L/min (24 USgpm)
Fluid compatibility:	Compatible with most petroleum oil, water glycol, oil-in-water and water-in-oil fluids. Optional seals available for phosphate esters.	
Temp range:	-26°C to +121°C (-15°F to +250°F)	
Pressure rating:	Operating	280 bar (4000 PSI)
	Fatigue	280 bar (4000 PSI)
Material:	Head	Ductile iron
	Bowl	Carbon Steel
Dry weight: (Approximate)	Length 1	4,6 kg (10.1lbs)
	Length 2	5,9 kg (13.4lbs)

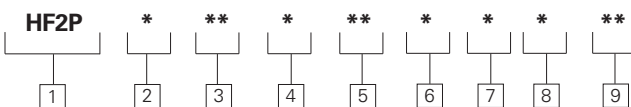

HF2P Series Filter and Element Model Code

Sample model code:

HF2P1SA4LNB2C05

1 Filter Series - HF2P

2 Element Collapse Rating

1 - 250 PSI Low Collapse
4 - 3000 PSI High Collapse
Note: Eaton's low pressure collapse rating have improved from 150 PSI to 250 PSI

3 Port Options

BA - G3/4 to ISO 228
SA - 1.062 - 12UN SAE-12 (3/4" tube)
WS - Subplate mounting

4 Valve Options

1 - Non-Bypass
4 - Bypass set at 43 PSI cracking pressure
6 - Bypass set at 90 PSI cracking pressure

5 Indicator Options

AN - Visual 70 PSI, No Connector
JN - No Indicator (plug), No Connector
LN - Visual 30 PSI, No Connector

ON - Visual 115 PSI, No Connector

RB - Electrical 30 PSI, Brad Harrison

RH - Electrical 30 PSI, Hirshman

RJ - Electrical 30 PSI, Hirshman w 24 volt light

RK - Electrical 30 PSI, Hirshman w 115 volt light

RL - Electrical 30 PSI, Hirshman w 230 volt light

TB - Electrical 115 PSI, Brad Harrison

TH - Electrical 115 PSI, Hirshman

TJ - Electrical 115 PSI, Hirshman w 24 volt light

TK - Electrical 115 PSI, Hirshman w 115 volt light

TL - Electrical 115 PSI, Hirshman w 230 volt light

UB - Electrical 70 PSI, Brad Harrison

UH - Electrical 70 PSI, Hirshman

UJ - Electrical 70 PSI, Hirshman w 24 volt light

UK - Electrical 70 PSI, Hirshman w 115 volt light

UL - Electrical 70 PSI, Hirshman w 230 volt light

6 Seal Material

B - Buna-N
V - Viton-A

7 Assembly Length

mm (inch)
1 - 211.9 (8.3)
2 - 304.9 (12.0)

8 Element Construction

C - 250 PSI Low Collapse
H - 3000 PSI High Collapse

9 Fluid Cleanliness Rating

Code	Target fluid cleanliness level
03	16/14/12 or better
05	18/16/14 or better
10	20/18/15 or better
20	22/19/16 or better

Pressure Filters

HF2P Series

Flows to 90 L/min (24 USgpm)
Pressures to 280 bar (4000 PSI)

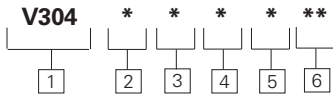

V304 Element Model Code

Sample model code:

V3041B1C05

1 Filter Element

V304 - For use with HF2P series filters

2 Element Collapse Rating

1 - 250 PSI (C-Pak only)
5 - 3000 PSI (H-Pak only)
NOTE: Use 1 only with bypass valve or monitored P indicator.

3 Seal Material

B - Buna-N
V - Viton-A

4 Element Length

mm (inch)
1 - 101 (4)
2 - 203 (8)

5 Element Construction

C - C-Pak (grade 3, 5, 10, 20)
H - H-Pak (grade 3, 5, 10)

6 Fluid Cleanliness Ratings

Code	Target fluid cleanliness level
03	16/14/12 or better
05	18/16/14 or better
10	20/18/15 or better
20	22/19/16 or better

Housing Dimensions

mm (inch)

Subplate Mounting

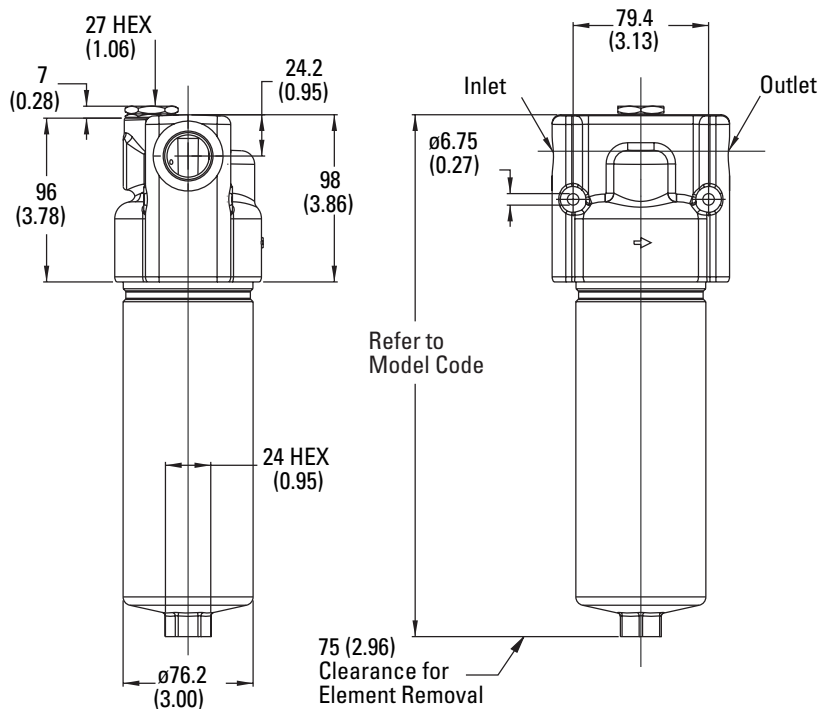
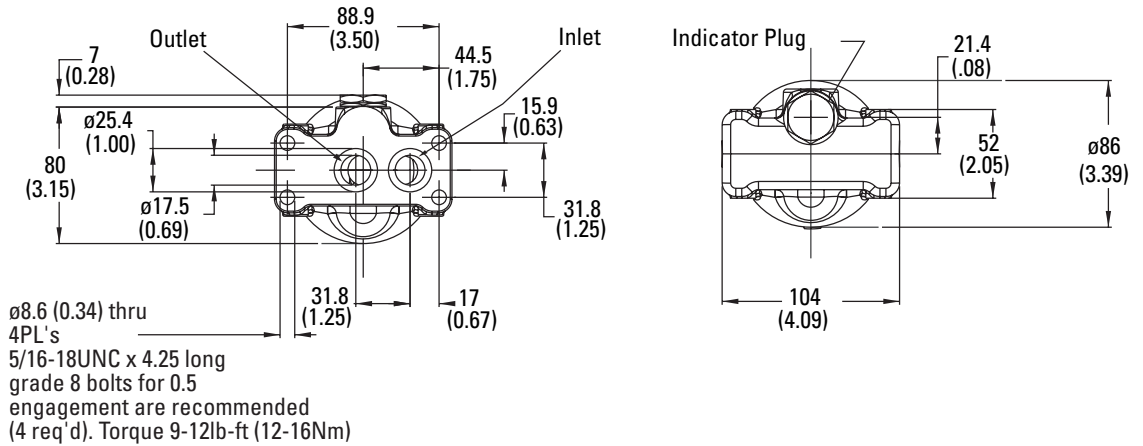

Items not in bold are non-standard and may have a longer lead time

Pressure Filters

Flows to 90 L/min (24 USgpm)
Pressures to 280 bar (4000 PSI)

HF2P Series

Flow Data

Flow versus pressure drop:

150 SUS (32 cSt) oil with specific gravity of ≤ 0.9

Element Flow Data

HF2P C-Pak Length 1

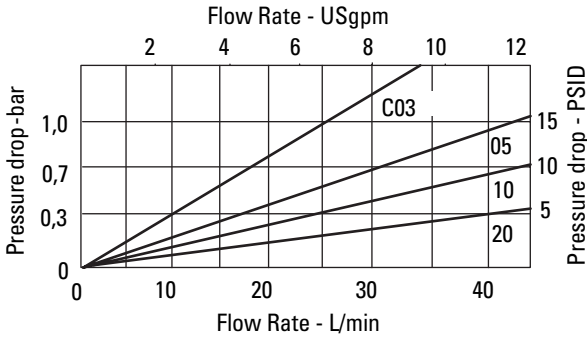

HF2P H-Pak Length 1

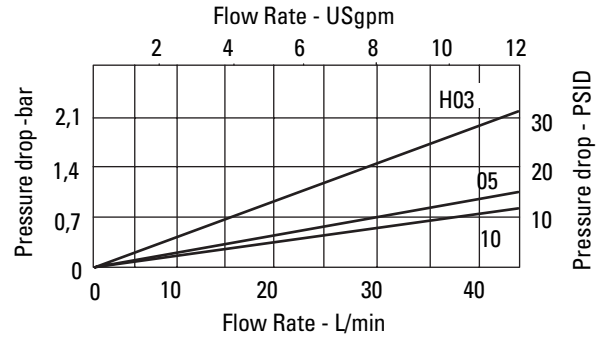

HF2P C-Pak Length 2

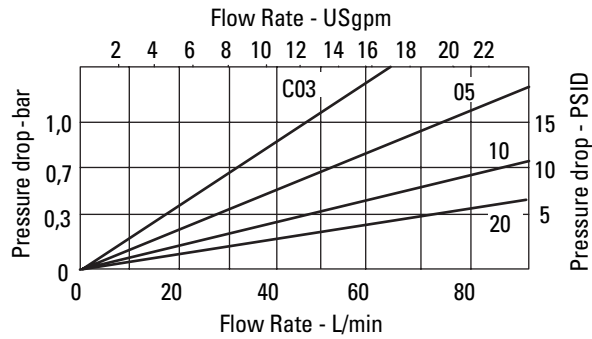

HF2P H-Pak Length 2

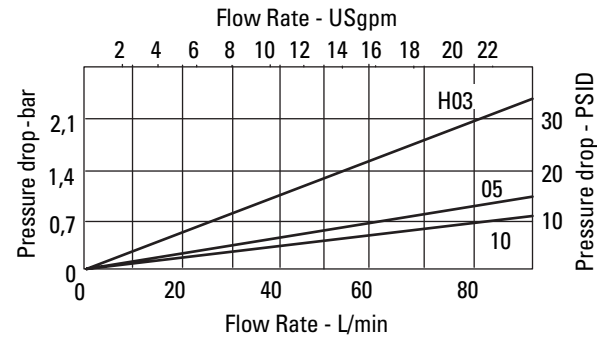

Housing/Bypass Valve Flow Data

Housing

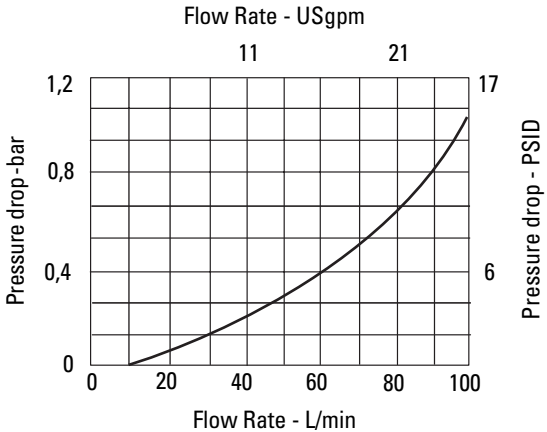

Bypass Valve

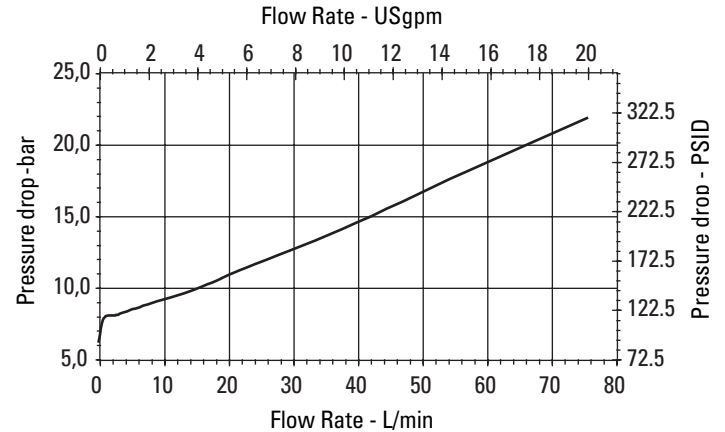

Pressure Filters

MF2P Series

Flows to 113.5 L/min (30 USgpm)
Pressures to 275.5 bar (4000 PSI)



Features and Benefits

- Designed to comply with ANSI specifications and ISO cleanliness standards.
- Visual, electrical, and electrical indicators with lamp options for system design flexibility.
- High efficiency replacement elements in standard configurations (C-Pak) to meet Target Cleanliness Levels.
- Poppet type leak by-pass valve construction.

DESIGN SPECIFICATIONS

Rated flow:	Length 5	68 L/min (18 USgpm)
	Length 7	113.5 L/min (30 USgpm)
Fluid compatibility:	Compatible with most petroleum oil, oil-in-water and water-in-oil fluids. Optional seals available for phosphate esters.	
Temp range:	-26°C to +121°C (-15°F to +250°F)	
Pressure rating:	Operating	276 bar (4000 PSI)
	Fatigue	276 bar (4000 PSI)
Material:	Head	Ductile iron
	Bowl	Steel
Dry weight: (Approximate)	Length 5	3,9 kg (8.3 lbs)
	Length 7	4,5 kg (9.9 lbs)

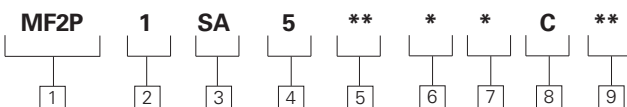

MF2P Series Filter Assembly Model Code

Sample model code:
MF2P1SA5UNB5C05

1 Filter Series - MF2P

2 Element Collapse Rating

1 - 250 PSI Low Collapse

3 Port Options

SA - 1.062 - 12UN SAE-12
(3/4" tube)

4 Valve Options

5 - Bypass set at 100 PSI
(7 bar) cracking pressure

5 Indicator Options

AN - Visual 70 PSI,
No Connector

JN - No Indicator (plug),
No Connector

UB - Electrical 70 PSI,
Brad Harrison

UJ - Electrical 70 PSI,
Hirshman w 24 volt light

UK - Electrical 70 PSI,
Hirshman w 115 volt light

UL - Electrical 70 PSI,
Hirshman w 230 volt light

UH - Electrical 70 PSI,
Hirshman

6 Seal Material

B - Buna-N

V - Viton-A

7 Assembly Length

mm (inch)

5 - 210 (8.27)

7 - 263 (10.36)

8 Element Construction

C - 250 PSI Low Collapse

9 Fluid Cleanliness Rating

Code	Target fluid cleanliness level
03	16/14/12 or better
05	18/16/14 or better
10	20/18/15 or better
20	22/19/16 or better

Items not in bold are non-standard and may have a longer lead time

Pressure Filters

MF2P Series

Flows to 113.5 L/min (30 USgpm)
Pressures to 275.5 bar (4000 PSI)

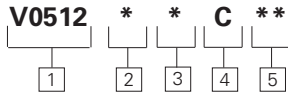

V0512 Element Model Codes

Sample model code:

V0512B5C05

1 Filter Element

V0512 - For use with MF2P series housings

2 Seal Material

B - Buna-N
V - Viton-A

3 Element Length

mm (inch)
5 - 117 (5)
7 - 169 (7)

4 Element Construction

C - C-Pak (grade 3, 5, 10, 20)

9 Fluid Cleanliness Rating

Code	Target fluid cleanliness level
03	16/ 14 /12 or better
05	18/ 16 /14 or better
10	20/ 18 /15 or better
20	22/ 19 /16 or better

Housing Dimensions

mm (inch)

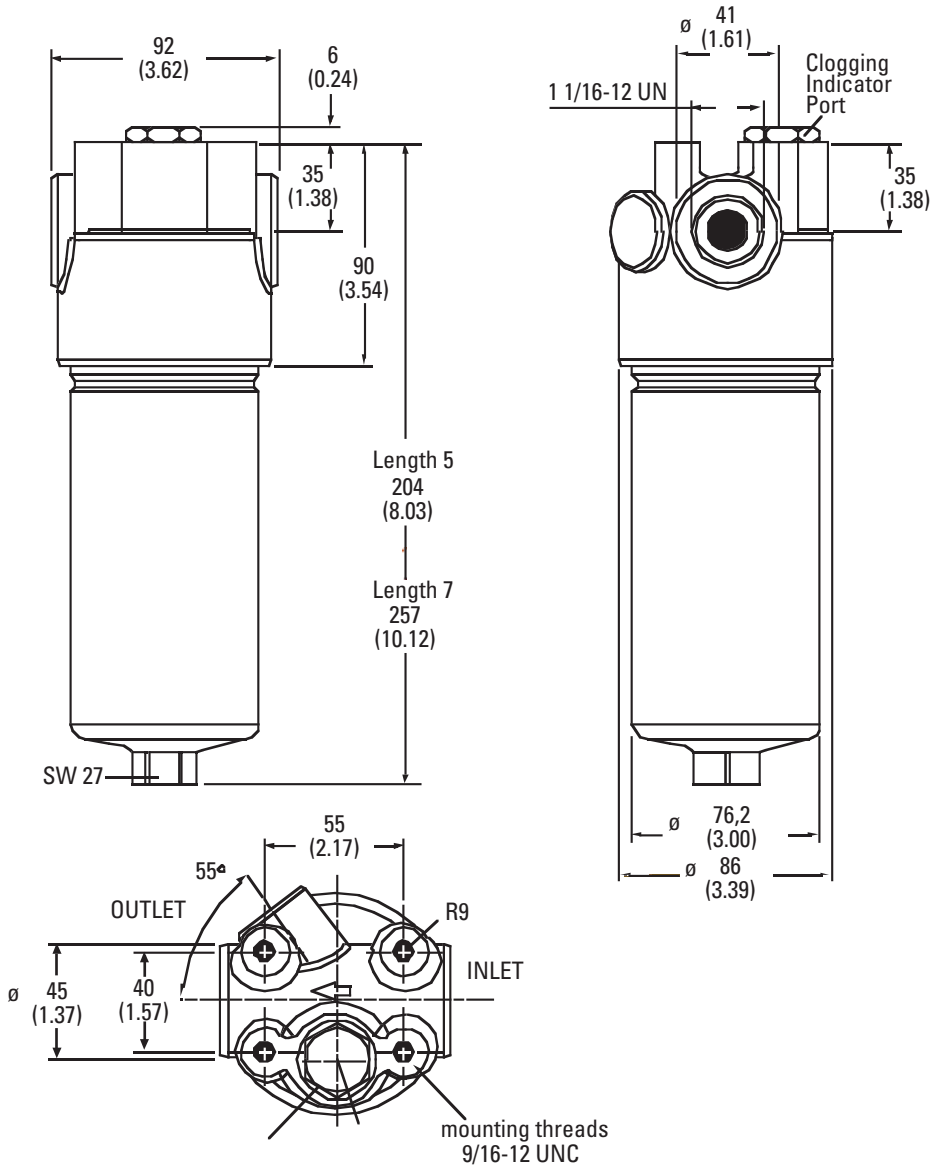

Items not in bold are non-standard and may have a longer lead time

Pressure Filters

Flows to 113.5 L/min (30 USgpm)
Pressures to 275.5 bar (4000 PSI)

MF2P Series

Flow Data

Flow versus pressure drop:

150 SUS (32 cSt) oil with specific gravity of ≤ 0.9

Element Flow Data

MF2P Length 5

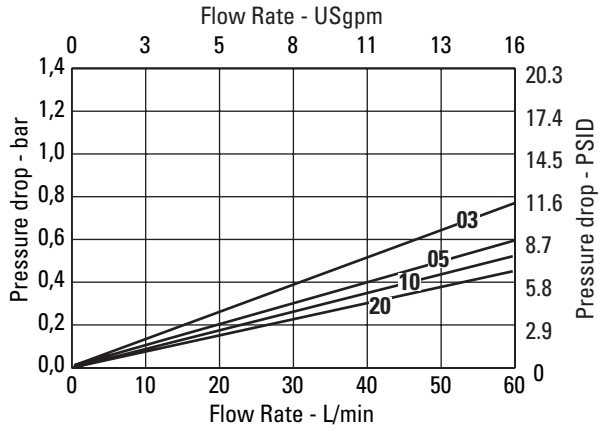

MF2P Length 7

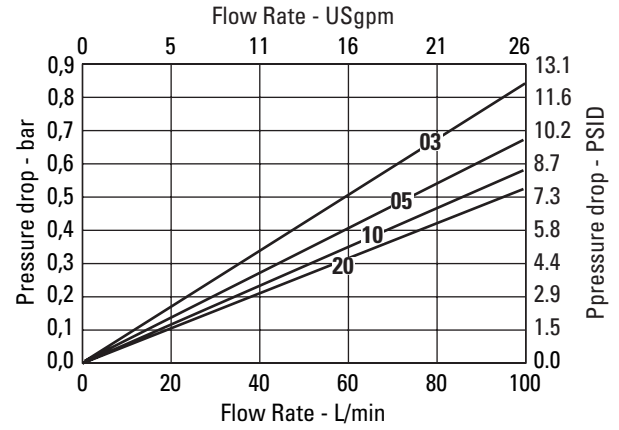

Housing/Bypass Valve Flow Data

Housing

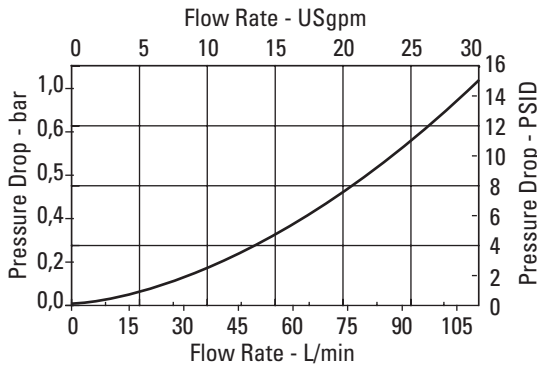

Bypass

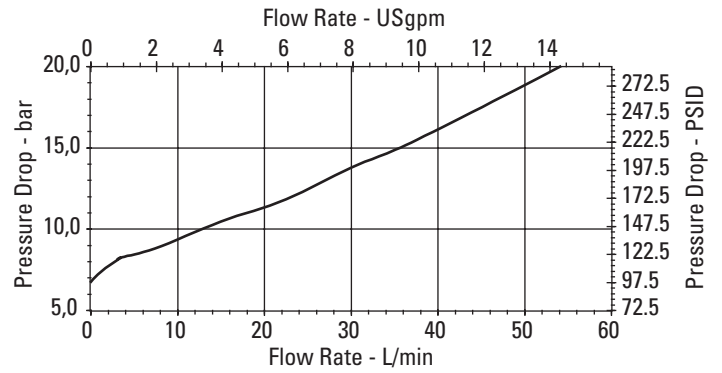

Pressure Filters

OFPH03, OFPH05 Series

Flows to 22 L/min (6 USgpm)
Pressures to 310 bar (4500 PSI)



Features and Benefits

- Designed to comply with ANSI specifications and ISO cleanliness standards.
- Visual, electrical, and electrical indicators with lamp options for system design flexibility.
- Poppet type by-pass valve construction.
- Wide range of element lengths for maximum design flexibility.
- High efficiency replacement elements in standard configurations (H-Pak) to meet Target Cleanliness Levels.
- Designed to mount directly underneath D03, D05 and CETOP Valves. The fluid is filtered prior to entering the valve "P" (Pressure) Port.

DESIGN SPECIFICATIONS

Rated flow:	Length 3	23 L/min (6 USgpm)
	Length 5	45 L/min (12 USgpm)
	Length 6	53 L/min (14 USgpm)
Fluid Compatibility:	Compatible with most petroleum oil, water glycol, oil-in-water and water-in-oil fluids. Optional seals available for phosphate esters.	
Temp range:	26°C to +121°C (-15°F to +250°F)	
Pressure Rating:	Operating:	310 bar (4500 psi)
	Fatigue:	310 bar (4500 psi)
Material:	Head Bowl	Ductile Iron Carbon Steel
Dry weight: (Approximate)	Length 3	2,3 kg (5.1 lbs)
	Length 5	4,7 kg (10.4 lbs)
	Length 6	5,4 kg (11.9 lbs)

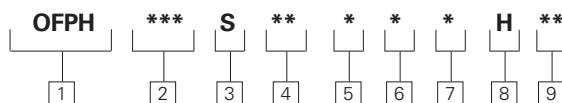

OFPH Series Filter Model Codes

Sample model code:

OFPH031SAATNBH03

[1] Filter Series - OFPH

[2] Bowl Length

mm (inch)

031 - OFPH031 226 (8.9)

051 - OFPH051 254 (10.0)

052 - OFPH052 325 (12.8)

[3] Valve Options

S - Without bypass valve

[4] Port Options

AA - Modular stacking,
Bowl Side A

BB - Modular stacking,
Bowl Side B

[5] Indicator Options

TN - Visual 115 PSI,
No Connector

JN - No Indicator (plug),
No Connector

TB - Electrical 115 PSI,
Brad Harrison

TJ - Electrical 115 PSI,
Hirshman w 24 volt light

TK - Electrical 115 PSI,
Hirshman w 115 volt light

TL - Electrical 115 PSI,
Hirshman w 230 volt light

TH - Electrical 115 PSI,
Hirshman

[7] Element Series (collapse rating)

H - 207 bar (3000 psi)

[8] Fluid Cleanliness Rating

Code **Target fluid cleanliness level**

03 16/14/12 or better

05 18/16/14 or better

10 20/18/15 or better

20 22/19/16 or better

[6] Seals

B - Buna-N

V - Viton-A

Items not in bold are non-standard and may have a longer lead time

Pressure Filters

Flows to 22 L/min (6 USgpm)
Pressures to 310 bar (4500 PSI)

OFPH03, OFPH05 Series

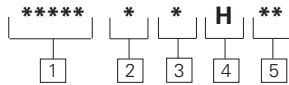

V0603, V0604 and V0114 Series Replacement Element Model Codes

Sample model code:
V0603B3H03

1 Element Series

V0603 - For use with OFPH031 series filters
V0604 - For use with OFPH051 series filters
V0114 - For use with OFPH052 series filters

2 Seals

B - Buna-N
V - Viton-A

3 Element Length

3 - OFPH031 3.7 (V0603 only)
5 - OFPH051 3.5 (V0604 only)
6 - OFPH052 6 (V0114 only)

4 Element Collapse Pressure

H - 207 bar (3000 psi)

5 Fluid Cleanliness Rating

03	16/14/12 or better
05	18/16/14 or better
10	20/18/15 or better
20	22/19/16 or better

Housing Dimensions

mm (inch)

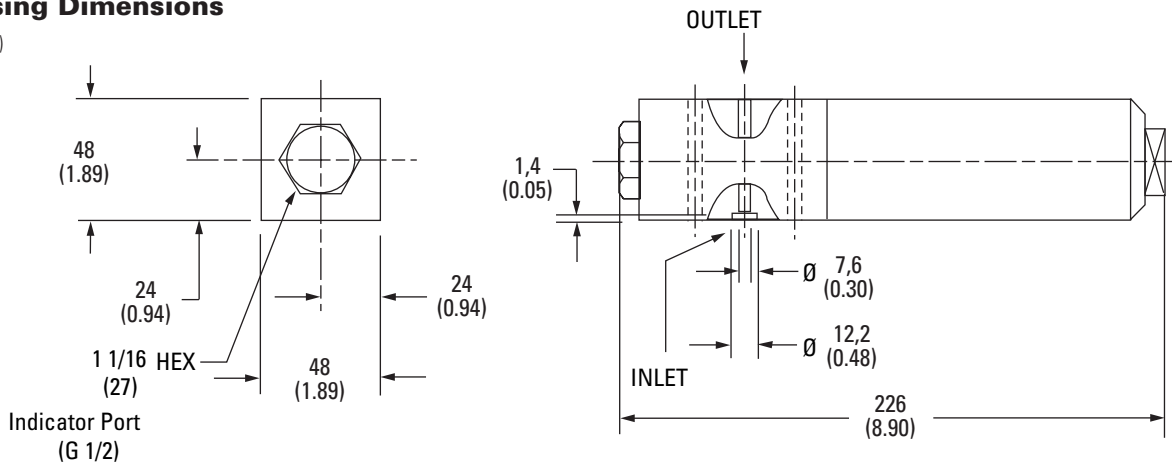

Note: A1 = A side = Right Side
B2 = B side = Left Side

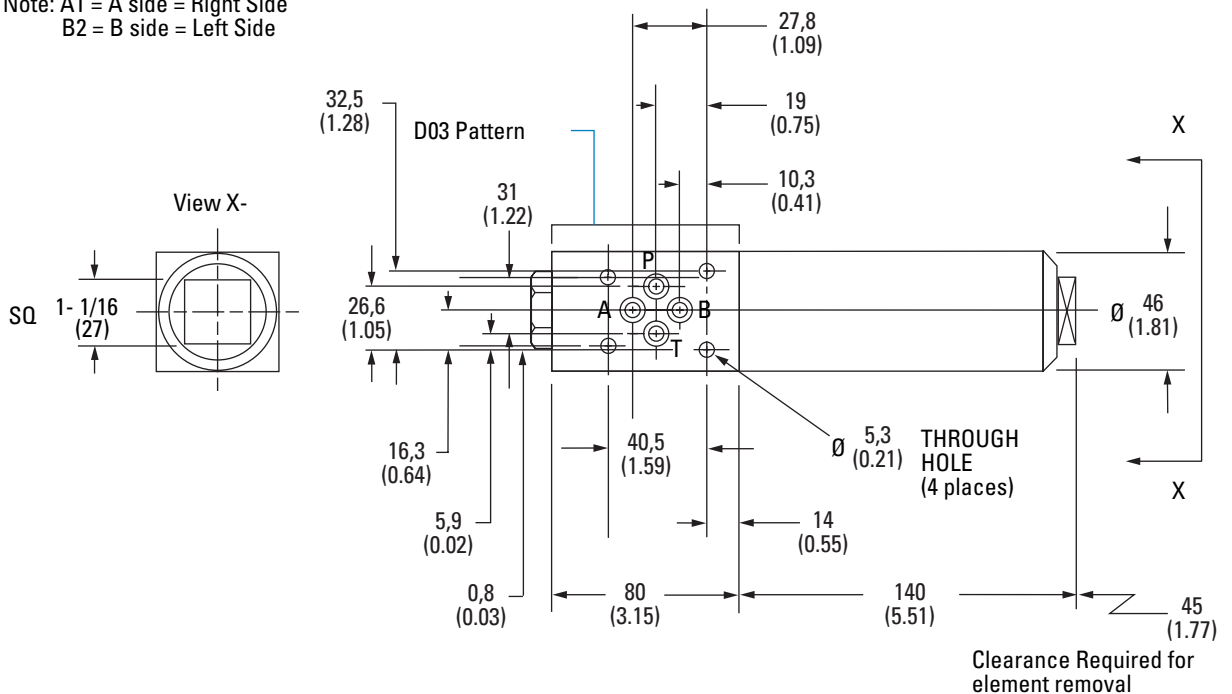

Items not in bold are non-standard and may have a longer lead time

Pressure Filters

Flows to 22 L/min (6 USgpm)
Pressures to 310 bar (4500 PSI)

OFPH03, OFPH05 Series

Flow versus pressure drop:

150 SUS (32 cSt) oil with specific gravity of ≤ 0.9

Flow Data

Element Flow Data

OFPH031

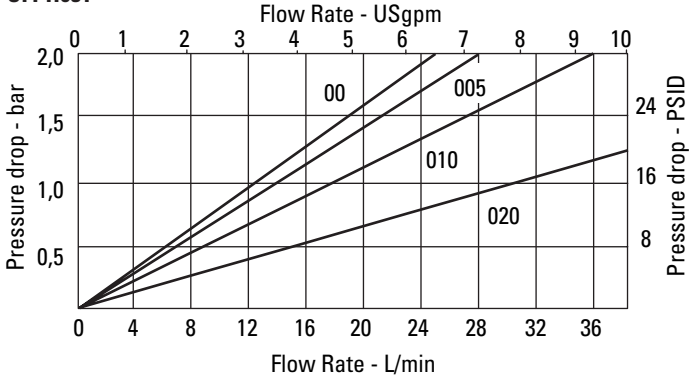

OFPH051

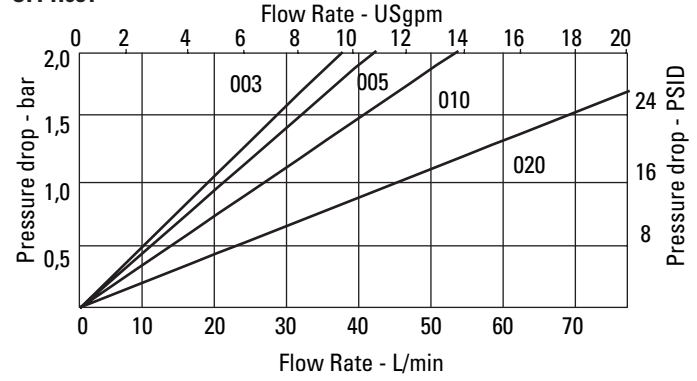

OFPH052

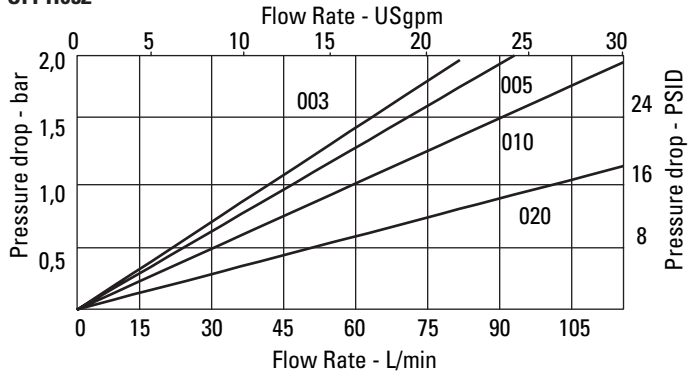

Housing Flow Data

OFPH031

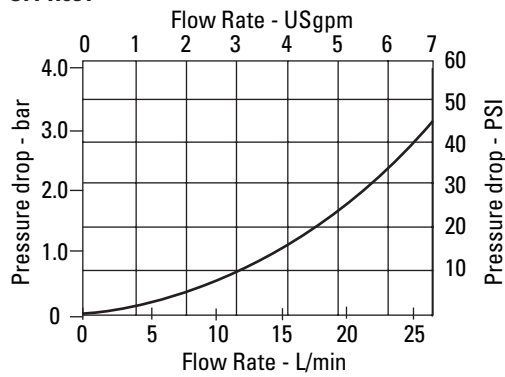

OFPH051

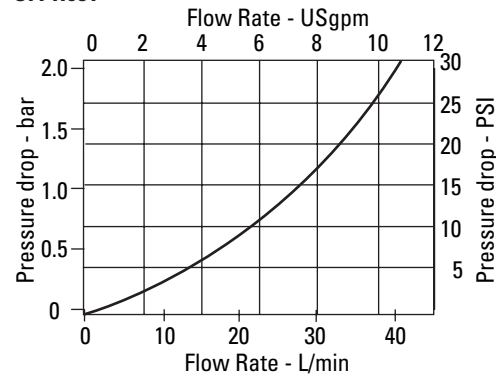

OFPH052

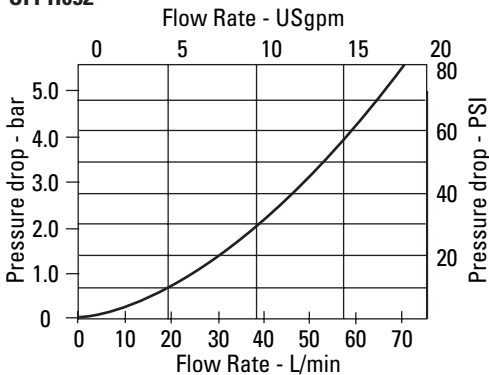

Pressure Filters

HF4P Series

Flows to 570 L/min (150 USgpm)
Pressures to 345 bar (5000 PSI)



Features and Benefits

- Designed to comply with ANSI specifications and ISO cleanliness standards.
- Visual, electrical, and electrical indicators with lamp options for system design flexibility
- Conforms to HF4 specifications
- Fatigue rated to 5000 PSI for maximum reliability in rugged applications
- Top loading design to ease maintenance and minimize spillage
- Multiple filter element lengths for design flexibility.
- High efficiency replacement elements in standard configurations (C-Pak) to meet Target Cleanliness Levels
- High collapse elements available for non-bypass applications.

Series Filter and Element Model Code

Sample model code:
HF4P1SD4LNB6C05

DESIGN SPECIFICATIONS

Rated flow:	Length 3	189 L/min (50 USgpm)
	Length 6	379 L/min (100 USgpm)
	Length 7	568 L/min (150 USgpm)
Fluid compatibility:	Compatible with most petroleum oil, water glycol, oil-in-water and water-in-oil fluids. Optional seals available for phosphate esters.	
Temp range:	-26°C to +121°C (-15°F to +250°F)	
Pressure rating:	Operating	345 bar (5000 PSI)
	Fatigue	345 bar (5000 PSI)
Material:	Head	Ductile Iron
	Bowl	Carbon Steel
	Lid	Ductile Iron
Dry weight: (Approximate)	Length 3	28,8 kg (63.4 lbs)
	Length 6	38,7 kg (85.3 lbs)
	Length 7	51,5 kg (113.6 lbs)

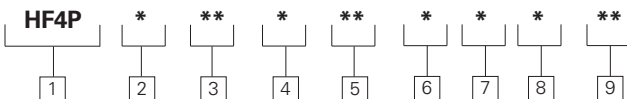

1 Filter Series - HF4P

2 Element Collapse Rating

- 1 - 150 PSI Low Collapse
- 4 - 3000 PSI High Collapse

3 Port options

- BD - G1½ to ISO 228
- ME - 1½" SAE 4 bolt Flange Code 61 (M12 x 1.75)
- MR - 1½" SAE 4 bolt Flange Code 62 (M16 x 2.0)
- SD - 1.875 - 12 UN SAE-24 str. Thd. (1½" tube)
- FE - 1½" SAE 4 bolt Flange Code 61 (UNC)
- FR - 1½" SAE 4 bolt Flange Code 62 (UNC)
- WS - Subplate mounting

4 Valve options

- 1 - Non-Bypass
- 4 - Bypass set at 43 PSI cracking pressure
- 6 - Bypass set at 90 PSI cracking pressure

5 Indicator options

- AN - Visual 70 PSI, No Connector
- LN - Visual 30 PSI, No Connector
- JN - No Indicator (plug), No Connector
- RB - Electrical 30 PSI, Brad Harrison
- RJ - Electrical 30 PSI, Hirshman w/ 24 volt light
- RK - Electrical 30 PSI, Hirshman w/ 115 volt light
- RL - Electrical 30 PSI, Hirshman w/ 230 volt light
- RH - Electrical 30 PSI, Hirshman
- TB - Electrical 115 PSI, Brad Harrison
- TJ - Electrical 115 PSI, Hirshman w/ 24 volt light
- TK - Electrical 115 PSI, Hirshman w/ 115 volt light
- TL - Electrical 115 PSI, Hirshman w/ 230 volt light
- TH - Electrical 115 PSI, Hirshman
- UB - Electrical 70 PSI, Brad Harrison

- UJ - Electrical 70 PSI, Hirshman w/ 24 volt light
- UK - Electrical 70 PSI, Hirshman w/ 115 volt light
- UL - Electrical 70 PSI, Hirshman w/ 230 volt light
- UH - Electrical 70 PSI, Hirshman

6 Seal material

- B - Buna-N
- V - Viton-A

7 Assembly Length

- mm (inch)
- 3 - 447 (17.6)
- 6 - 685.3 (27)
- 7 - 923.5 (36.4)

8 Element construction

- C - 150 PSI Low Collapse
- H - 3000 PSI High Collapse

9 Fluid cleanliness rating

Code	Target fluid cleanliness level
03	16/14/12 or better
05	18/16/14 or better
10	20/18/15 or better
20	22/19/16 or better

Items not in bold are non-standard and may have a longer lead time

Pressure Filters

HF4P Series

Flows to 570 L/min (150 USgpm)
Pressures to 345 bar (5000 PSI)

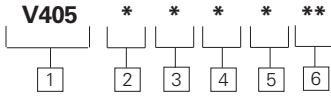

V405 Element model code

(Meets HF4 Standard)

Sample model code:

V4051B3C03

1 Filter Element - V405

2 Element Collapse Rating

1 - 150 PSI
4 - 3000 PSI High Collapse
NOTE: Use 1 only with bypass valve or monitored delta P indicator.

3 Seals

B - Buna-N
V - Viton-A

4 Element Length

mm (inch)
3 - 229 (9)
6 - 457 (18)
7 - 686 (27)

5 Element Construction

C - C-Pak (grade 3, 5, 10, 20)
H - H-Pak (grade 3, 5, 10)

6 Fluid Cleanliness Rating

Code	Target fluid cleanliness level
03	16/14/12
05	18/16/14
10	20/18/15
20	22/19/16

Housing Dimensions

mm (inch)

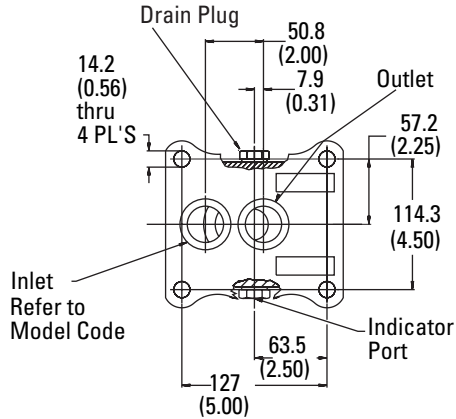
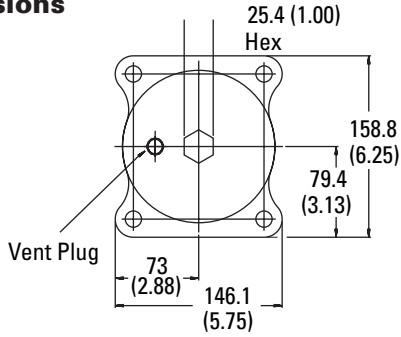

View X - Subplate Mounting

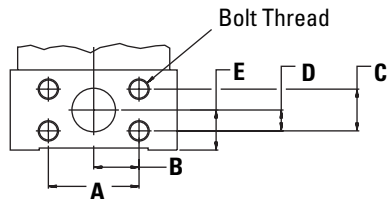
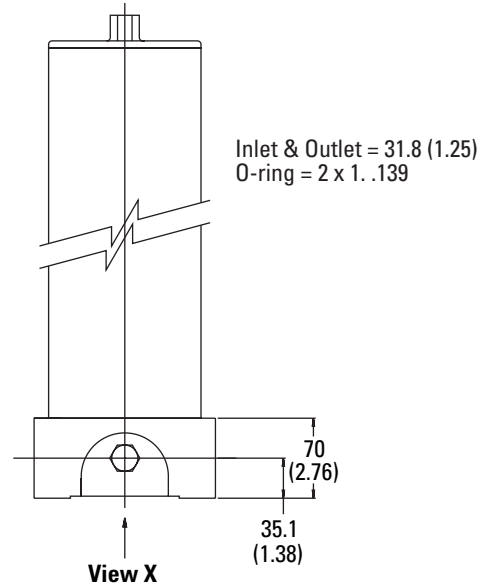
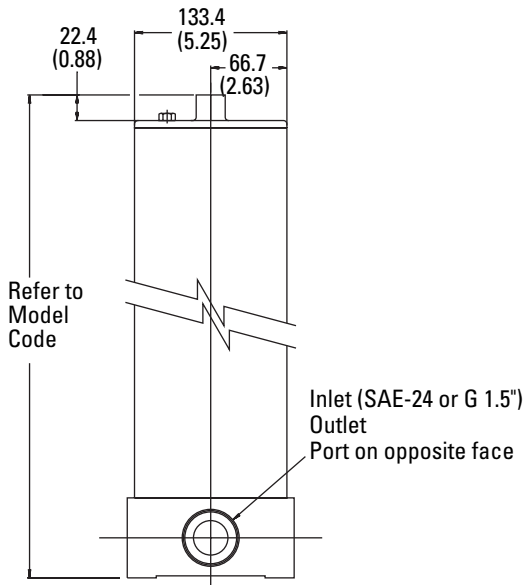

	A	B	C	D	E
	mm(inch)	mm(inch)	mm(inch)	mm(inch)	mm(inch)
ME	69.8 (2.75)	37.9 (1.375)	35.7 (1.406)	17.9 (.703)	35.1 (1.38)
MR	79.3 (3.125)	39.4 (1.56)	36.5 (1.437)	18.2 (.718)	35.1 (1.38)
FE	69.8 (2.75)	37.9 (1.375)	35.7 (1.406)	17.9 (.703)	35.1 (1.38)
FR	79.3 (3.125)	39.4 (1.56)	36.5 (1.437)	18.2 (.718)	35.1 (1.38)

Items not in bold are non-standard and may have a longer lead time

Pressure Filters

Flows to 570 L/min (150 USgpm)
Pressures to 345 bar (5000 PSI)

HF4P Series

Flow Data

Flow versus pressure drop:

150 SUS (32 cSt) oil with specific gravity of ≤ 0.9

Element Flow Data

HF4P C-Pak Element Length 3

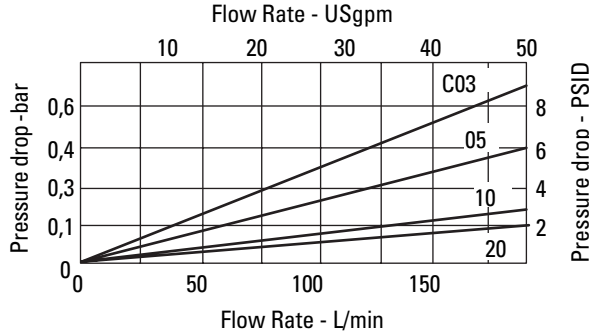

HF4P H-Pak Element Length 3

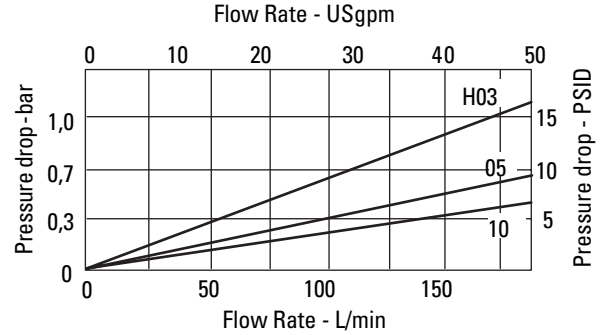

HF4P C-Pak Element Length 6

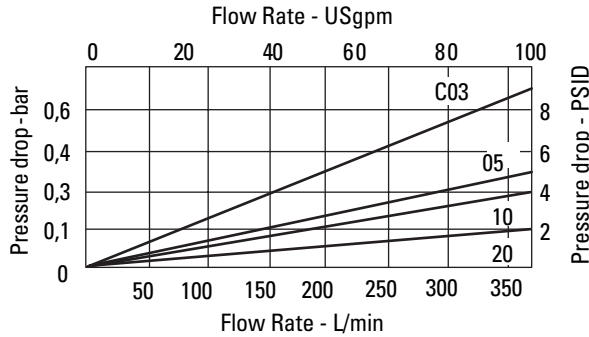

HF4P H-Pak Element Length 6

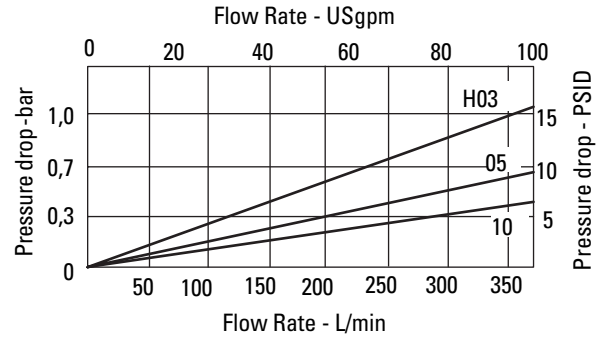

HF4P C-Pak Element Length 7

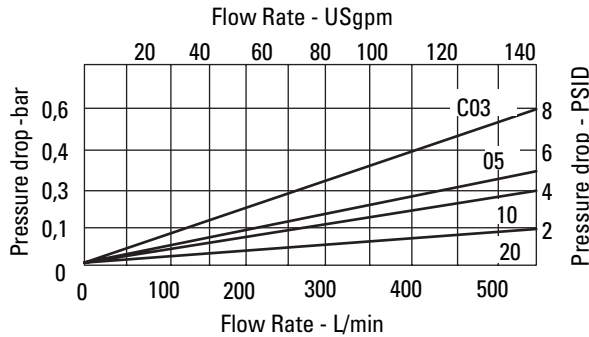

HF4P H-Pak Element Length 7

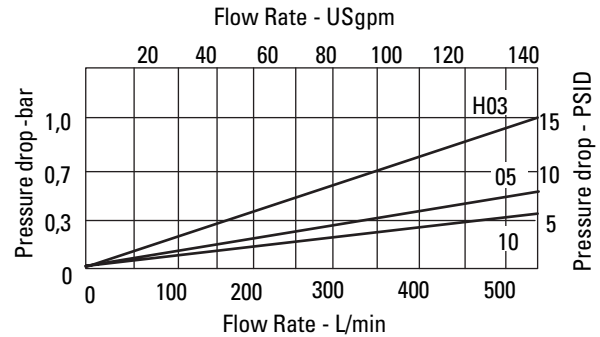

Housing/Bypass Valve Flow Data

Housing

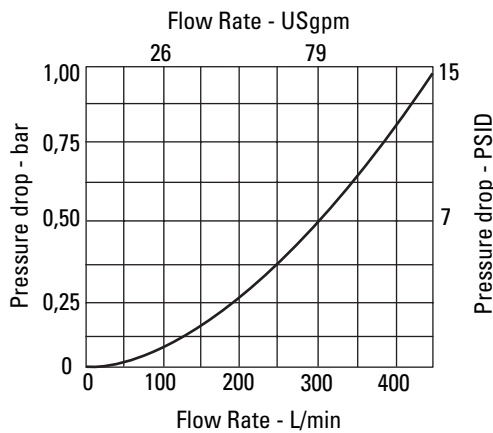

Bypass Valve

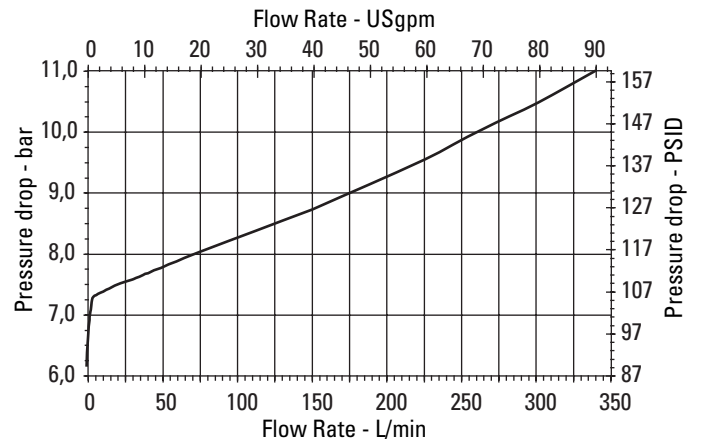

Pressure Filters

HF3P Series

Flows to 570 L/min (150 USgpm)
Pressures to 410 bar (6000 PSI)



Features and Benefits

- Designed to comply with ANSI specifications and ISO cleanliness standards.
- Visual, electrical, and electrical indicators with lamp options for system design flexibility
- Conforms to HF3 automotive specifications
- Fatigue rated to 6000 PSI for maximum reliability in the most rugged applications
- Reverse flow valve option for hydrostatic transmission applications.
- Multiple filter element lengths for design flexibility.
- High efficiency replacement elements in standard configurations (C-Pak) to meet Target Cleanliness Levels
- High collapse elements available for non-bypass applications.

DESIGN SPECIFICATIONS

Rated flow:	Length 1	106 L/min (28 USgpm)
	Length 2	208 L/min (55 USgpm)
	Length 4	344 L/min (91 USgpm)
	Length 5	454 L/min (120 USgpm)
Fluid compatibility:	Compatible with most petroleum oil, water glycol, oil-in-water and water-in-oil fluids. Optional seals available for phosphate esters.	
Temp range:	-26°C to +121°C (-15°F to +250°F)	
Pressure rating:	Operating	280 bar (4000 PSI)
	Fatigue	410 bar (6000 PSI)
Material:	Head	Ductile iron
	Bowl	Carbon Steel
Dry weight: (Approximate)	Length 1	20,3 kg (44.8lbs)
	Length 2	22,5 kg (49.5lbs)
	Length 4	28,5 kg (62.9lbs)
	Length 5	43,4 kg (95.7lbs)

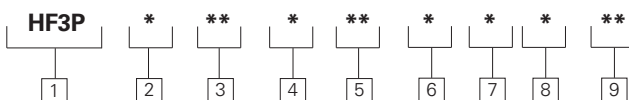

1 Filter Series - HF3P

2 Element Collapse Rating

- 1 - 250 PSI Low Collapse
4 - 3000 PSI High Collapse

3 Port Options

- BB - G1 to ISO 228
BD - G1-1/2 to ISO 228
ME - 1-1/2" SAE 4 bolt Flange
Code 61 (M12 x 1.75)
MJ - 2" SAE 4 bolt Flange
Code 61 (M12 x 1.75)
MU - 2" SAE 4 bolt Flange
Code 62 (M20 x 2.5)
SB - 1.312 - 12 UN SAE-16
str. Thd. (1" tube)
SD - 1.875 - 12 UN SAE-24
str. Thd. (1-1/2" tube)
FE - 1 1/2" SAE 4 bolt Flange
Code 61 (UNC)
FJ - 2" SAE 4 bolt Flange
Code 61 (UNC)
FU - 2" SAE 4 bolt Flange
Code 62 (UNC)

4 Valve Options

- 1 - Non-Bypass
4 - Bypass set at 43 PSI
cracking pressure
6 - Bypass set at 90 PSI
cracking pressure
8 - Reverse Flow Valve
Non-Bypass*
9 - Reverse Flow Valve 43 PSI
Bypass*

* Reverse flow bypass available with BD,
MU, SD and FU ports only.

5 Indicator Options

- AN** - Visual 70 PSI,
No Connector
JN - No Indicator (plug),
No Connector
KN - Visual 15 PSI,
No Connector
LN - Visual 30 PSI,
No Connector
ON - Visual 115 PSI,
No Connector
RB - Electrical 30 PSI,
Brad Harrison
RH - Electrical 30 PSI,
Hirshman
RJ - Electrical 30 PSI,
Hirshman w 24 volt light
RK - Electrical 30 PSI,
Hirshman w 115 volt light
RL - Electrical 30 PSI,
Hirshman w 230 volt light
TB - Electrical 115 PSI,
Brad Harrison
TH - Electrical 115 PSI,
Hirshman
TJ - Electrical 115 PSI,
Hirshman w 24 volt light
TK - Electrical 115 PSI,
Hirshman w 115 volt light
TL - Electrical 115 PSI,
Hirshman w 230 volt light
UB - Electrical 70 PSI,
Brad Harrison
UH - Electrical 70 PSI,
Hirshman
UJ - Electrical 70 PSI,
Hirshman w 24 volt light

- UK** - Electrical 70 PSI,
Hirshman w 115 volt light
UL - Electrical 70 PSI,
Hirshman w 230 volt light

6 Seal Material

- B** - Buna-N
V - Viton-A

7 Assembly Length

- mm (inch)
1 - 230 (9.1)
2 - 293 (11.5)
4 - 414 (16.3)
5 - 569 (22.4)

8 Element Construction

- C** - 250 PSI Low Collapse
H - 3000 PSI High Collapse

9 Fluid Cleanliness Rating

Code	Target fluid cleanliness level
03	16/14/12 or better
05	18/16/14 or better
10	20/18/15 or better
20	22/19/16 or better

HF3P Series Filter and Element Model Code

Sample model code:

HF3P1SB4LNB2C05

Pressure Filters

HF3P Series

Flows to 570 L/min (150 USgpm)
Pressures to 420 bar (6000 PSI)

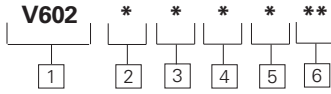

V602 Element Model Code

Sample model code:
V6021B1C03

1 Filter element

V602 - For use with HF3P, HF3PS and OFR30 series filters

2 Element collapse rating

1 - 250 PSI Collapse
4 - 3000 PSI High Collapse
NOTE: Use 1 only with bypass valve. Eaton's low collapse ratings have improved from 150 to 250 PSI

3 Seal material

B - Buna-N
V - Viton-A

4 Element length

mm (inch)
1 - 101 (4)
2 - 203 (8)*
4 - 330 (13)
5 - 406 (16)
*HF3

5 Element construction

C - C-Pak (grade 3, 5, 10, 20)
H - H-Pak (grade 3, 5, 10)

6 Fluid cleanliness rating

Code	Target fluid cleanliness level
03	16/14/12 or better
05	18/16/14 or better
10	20/18/15 or better
20	22/19/16 or better

Housing Dimensions

mm (inch)

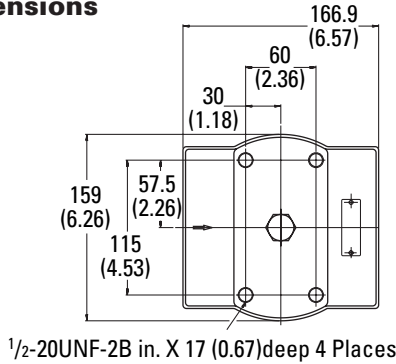

Inlet & Outlet Porting

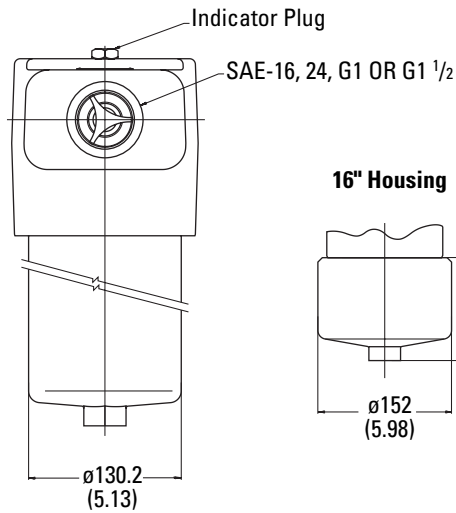
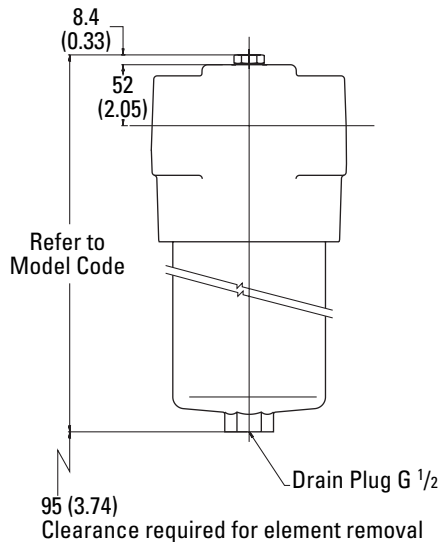
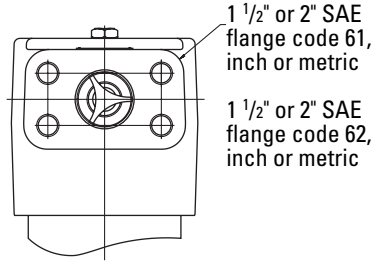

16" Housing

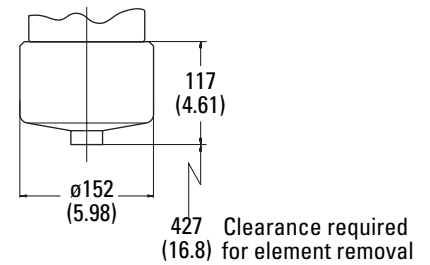

Housing/Bypass Valve Flow Data

Housing

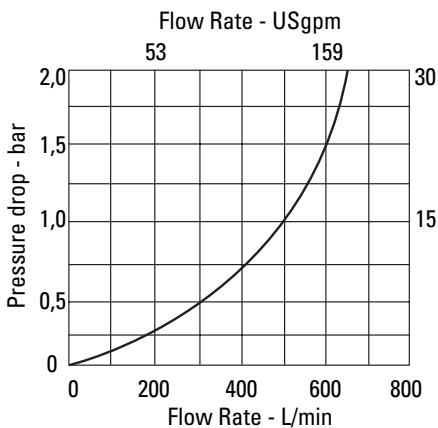

Bypass Valve

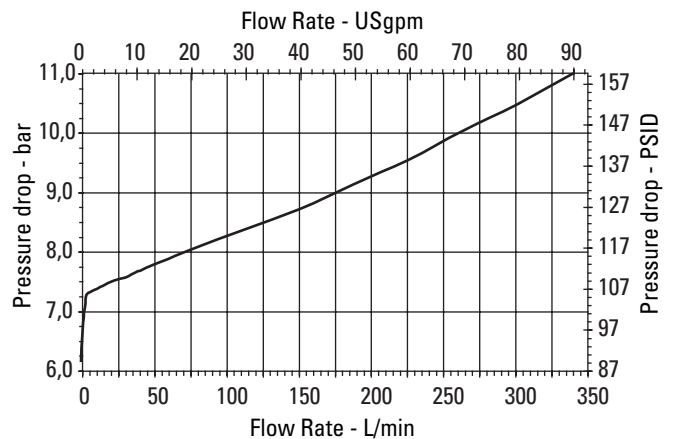

Items not in bold are non-standard and may have a longer lead time

Pressure Filters

Flows to 570 L/min (150 USgpm)
Pressures to 420 bar (6000 PSI)

HF3P Series

Flow Data

Flow versus pressure drop:

150 SUS (32 cSt) oil with specific gravity of ≤ 0.9

Element Flow Data

HF3P C-Pak Length 1

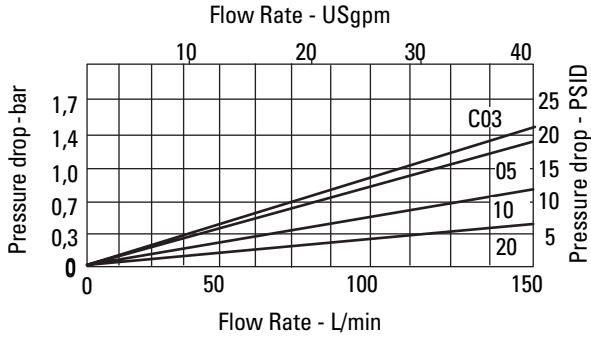

HF3P H-Pak Length 1

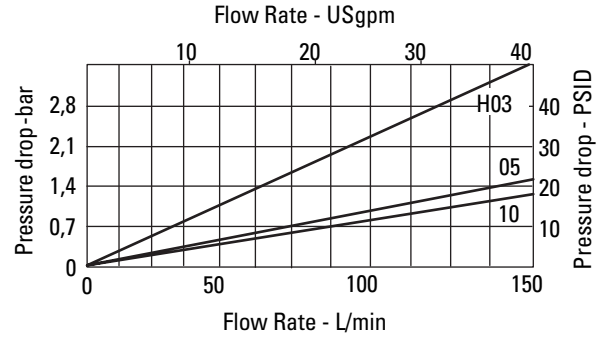

HF3P C-Pak Length 2

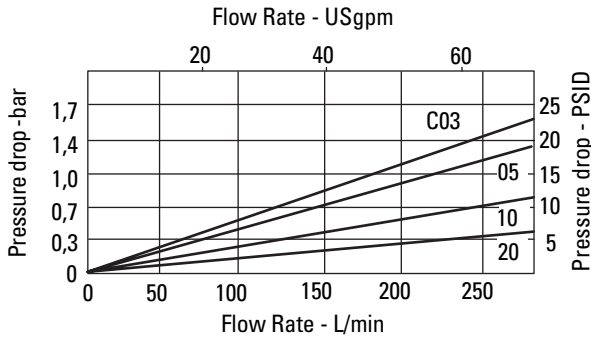

HF3P H-Pak Length 2

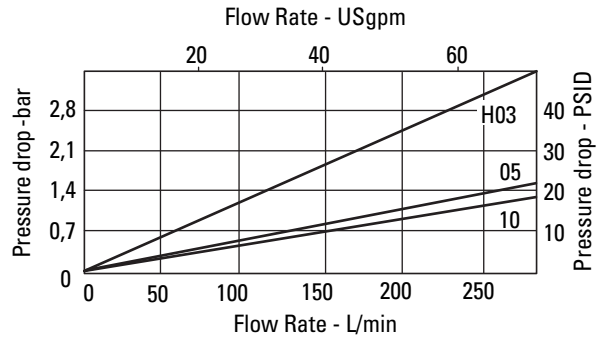

HF3P C-Pak Length 4

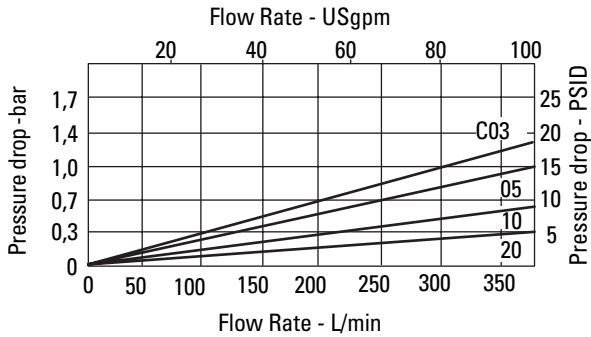

HF3P H-Pak Length 4

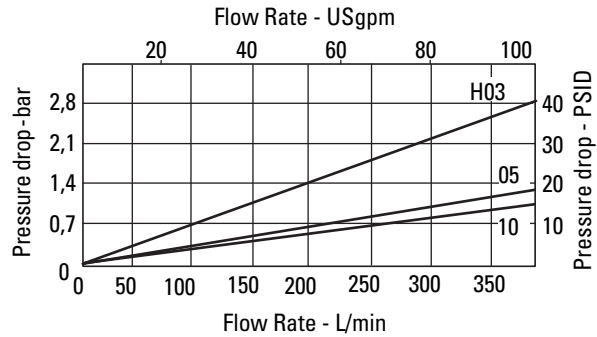

HF3P C-Pak Length 5

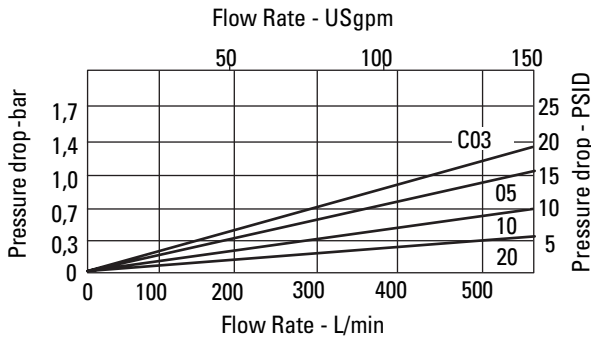

HF3P H-Pak Length 5

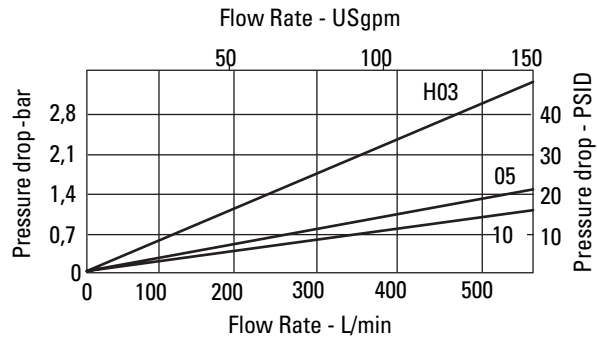

Pressure Filters

HF3PS Series

Flows to 570 L/min (150 USgpm)
Pressures to 410 bar (6000 PSI)



Features and Benefits

- Designed to comply with ANSI specifications and ISO cleanliness standards.
- Visual, electrical, and electrical indicators with lamp options for system design flexibility
- Conforms to HF3 automotive specifications
- Fatigue rated to 6000 PSI for maximum reliability in rugged applications
- Side manifold mounting for ease of maintenance in many applications.
- Multiple filter element lengths for design flexibility.
- High efficiency replacement elements in standard configurations (C-Pak) to meet Target Cleanliness Levels
- High collapse elements available for non-bypass applications.

DESIGN SPECIFICATIONS

Rated flow:	Length 2	265 L/min (70 USgpm)
	Length 4	454 L/min (120 USgpm)
	Length 5	565 L/min (150 USgpm)
Fluid compatibility:	Compatible with most petroleum oil, water glycol, oil-in-water and water-in-oil fluids. Optional seals available for phosphate esters.	
Temp range:	-26°C to +121°C (-15°F to +250°F)	
Pressure rating:	Operating	310 bar (4500 PSI)
	Fatigue	410 bar (6000 PSI)
Material:	Head	Ductile iron
	Bowl	Carbon Steel
Dry weight: (Approximate)	Length 2	21,8 kg (48.0 lbs)
	Length 4	28,5 kg (62.8 lbs)
	Length 5	41,4 kg (91.3 lbs)

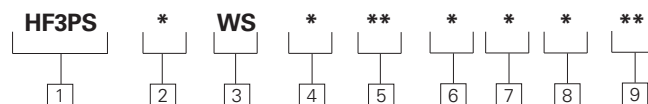

HF3PS Series Filter and Element Model Code

Sample model code:

HF3PS1WS4LNB5C05

1 Filter Series - HF3PS

2 Element Collapse Rating

- 1 - 250 PSI Low Collapse
- 4 - 3000 PSI High Collapse

3 Port Options

- WS - Subplate mounting

4 Valve Options

- 1 - Non-Bypass
- 4 - Bypass set at 43 PSI cracking pressure
- 6 - Bypass set at 90 PSI cracking pressure

5 Indicator Options

- AN - Visual 70 PSI, No Connector
- JN - No Indicator (plug), No Connector
- KN - Visual 15 PSI, No Connector
- LN - Visual 30 PSI, No Connector
- ON - Visual 115 PSI, No Connector

- RB - Electrical 30 PSI, Brad Harrison

- RH - Electrical 30 PSI, Hirshman

- RJ - Electrical 30 PSI, Hirshman w 24 volt light

- RK - Electrical 30 PSI, Hirshman w 115 volt light

- RL - Electrical 30 PSI, Hirshman w 230 volt light

- TB - Electrical 115 PSI, Brad Harrison

- TH - Electrical 115 PSI, Hirshman

- TJ - Electrical 115 PSI, Hirshman w 24 volt light

- TK - Electrical 115 PSI, Hirshman w 115 volt light

- TL - Electrical 115 PSI, Hirshman w 230 volt light

- UB - Electrical 70 PSI, Brad Harrison

- UH - Electrical 70 PSI, Hirshman

- UJ - Electrical 70 PSI, Hirshman w 24 volt light

- UK - Electrical 70 PSI, Hirshman w 115 volt light

- UL - Electrical 70 PSI, Hirshman w 230 volt light

6 Seal Material

- B - Buna-N
- V - Viton-A

7 Assembly Length

- mm (inch)
- 2 - 340 (13.3)
- 4 - 461 (18.1)
- 5 - 614 (24.2)

8 Element Construction

- C - 250 PSI Low Collapse
- H - 3000 PSI High Collapse

9 Fluid Cleanliness Rating

Code	Target fluid cleanliness level
03	16/14/12 or better
05	18/16/14 or better
10	20/18/15 or better
20	22/19/16 or better

Items not in bold are non-standard and may have a longer lead time

Pressure Filters

HF3PS Series

Flows to 570 L/min (150 USgpm)
Pressures to 310 bar (4500 PSI)

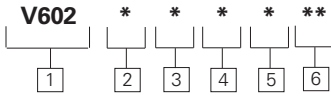

V602 Element Model Code

Sample model code:

V6021B1C03

1 Filter Element

V602 - For use with HF3P, HF3PS and OFR30 series filters

2 Element Collapse Rating

1 - 250 PSI Low Collapse
4 - 3000 PSI High Collapse
NOTE: Use 1 only with bypass valve.

3 Seal Material

B - Buna-N
V - Viton-A

4 Element Length

mm (inch)
1 - 101 (4)
2 - 203 (8)*
4 - 330 (13)
5 - 406 (16)
*HF3

5 Element Construction

C - C-Pak (grade 3, 5, 10, 20)
H - H-Pak (grade 3, 5, 10)

6 Fluid Cleanliness Rating

Code	Target fluid cleanliness level
03	16/14/12 or better
05	18/16/14 or better
10	20/18/15 or better
20	22/19/16 or better

Housing Dimensions

mm (inch)

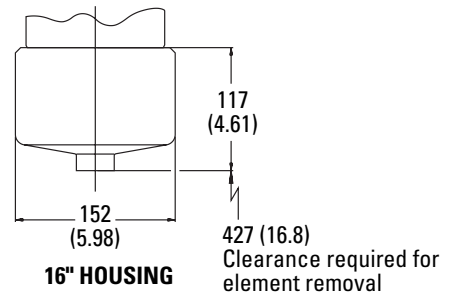
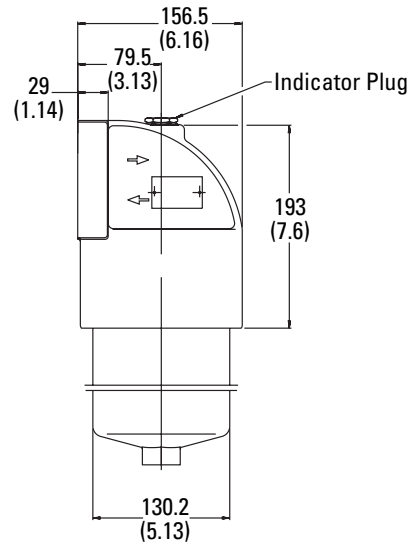
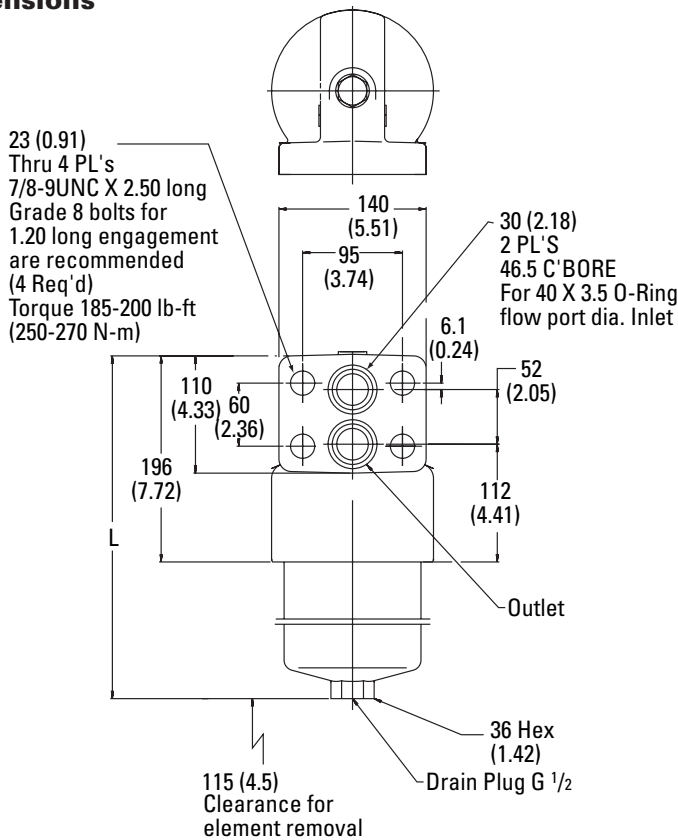

Pressure Filters

Flows to 570 L/min (150 USgpm)
Pressures to 310 bar (4500 PSI)

HF3PS Series

Flow Data

Flow versus pressure drop:

150 SUS (32 cSt) oil with specific gravity of ≤ 0.9

Element Flow Data

HF3PS C-Pak Element Length 2

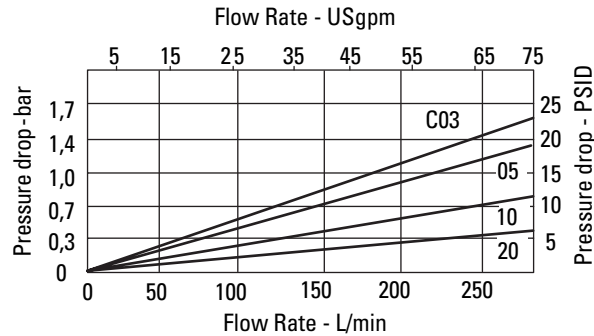

HF3PS H-Pak Element Length 2

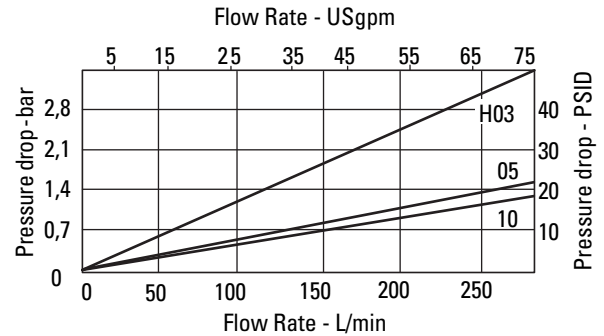

HF3PS C-Pak Element Length 4

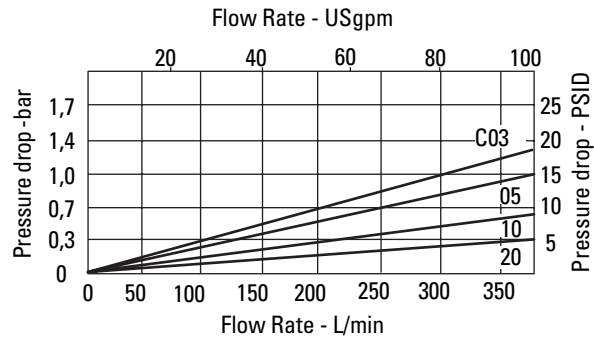

HF3PS H-Pak Element Length 4

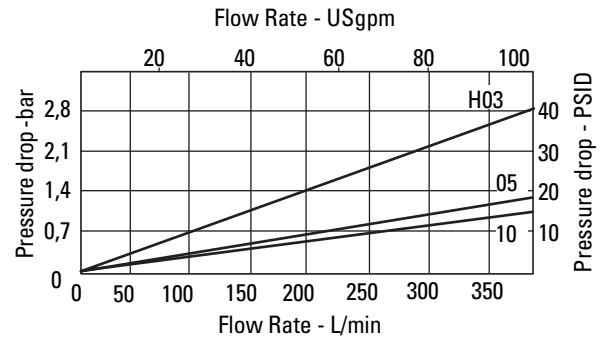

HF3PS C-Pak Element Length 5

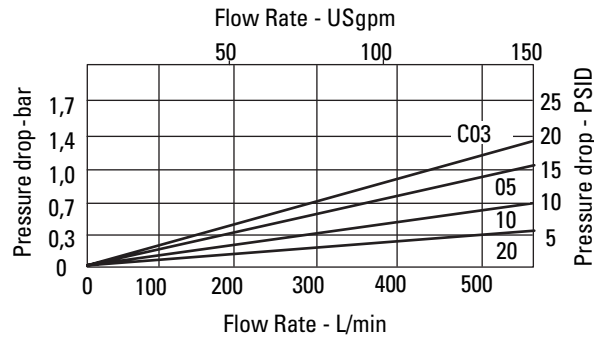

HF3PS H-Pak Element Length 5

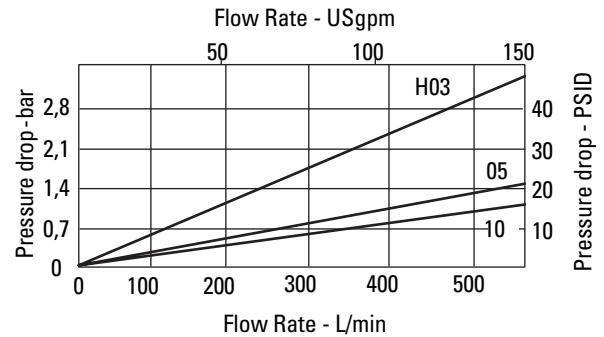

Housing/Bypass Valve Flow Data

Housing

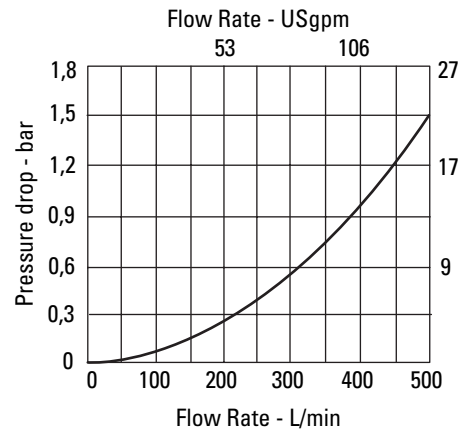

Bypass Valve

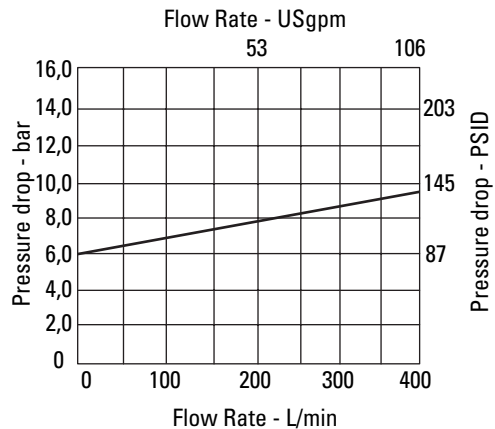

Pressure Filters

DMP DIN Series Filters

Flows to 100 L/min (25 USgpm)
Pressures to 100 bar (1450 PSI)



Features and Benefits

- Designed to Comply with DIN 24550 specifications
- Fatigue rated to 100 Bar
- Visual, electrical, and electrical indicators with light options for system design flexibility
- High efficiency six layer media elements
- Bypass and non-bypass options available

DESIGN SPECIFICATIONS

Rated flow:	040 063 100	40 L/min (11USgpm) 63 L/min (17USgpm) 100 L/min (26USgpm)
Fluid compatibility:	Compatible with most petroleum oil, oil-in-water and water-in-oil fluids. Optional seals available for phosphate esters	
Temp range:	-10°C to + 100°C (+14°F to +212°F)	
Pressure rating:	Fatigue	100 bar (1450 PSI)
Material:	040/063 100	Aluminum Aluminum and Steel
Dry weight:	040 063 100	1,8kg (4.0 lbs) 1,8kg (4.0 lbs) 4,2kg (9.3 lbs)

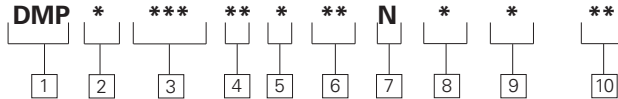

DMP Series Filter

Sample model code:

DRT1100BC41NBC06

1 Filter Series

DMP - DIN Medium Pressure

2 Element Collapse Rating

1 - 435 PSI Low Collapse

4 - 2320 PSI High Collapse

3 Nominal Size

040 - 40 L/min (10.6 USgpm)

063 - 63 L/min (16.6 USgpm)

100 - 100 L/min (26.4 USgpm)

4 Port Size

BB - G 1/2" (Length 040 only)

BC - G 3/4" (Length 063 only)

BD - G 1" (Length 100 only)

5 Valve Options

1 - Non-Bypass

4 - Bypass set at 100 PSI cracking pressure

6 Indicator Options

AN - Visual 70 PSI, No Connector

JN - No Indicator, No Connector

TB - Electrical 70 PSI, Brad Harrison Connector

TH - Electrical 70 PSI, Hirschman

7 Secondart Port

N - No Secondary Port

8 Seal Material

B - Buna-N

V - Viton-A

9 Element Construction

C - Standard Construction

H - High Collapse

10 Fluid Cleanliness Rating

Code **Target fluid cleanliness level**

03 **16/14/12 or better**

06 **18/16/14 or better**

10 **20/18/15 or better**

25 **22/19/16 or better**

Pressure Filters

DMP DIN Series

Filters

Flows to 100 L/min (25 USgpm)
Pressures to 100 bar (1450 PSI)

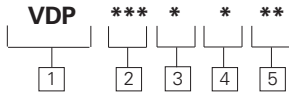

Element model code

Sample model code:

VDP160BC06

1 Filter Element

VDP - DIN Standard Element

2 Nominal Size

040 - 40 L/min (10.6 USgpm)

063 - 63 L/min (16.6 USgpm)

100 - 100 L/min (26.4 USgpm)

3 Seal Material

B - Buna-N

V - Viton-A

4 Element Construction

C - Standard Construction

H - High Collapse

5 Fluid Cleanliness Rating

Code	Target fluid cleanliness level
03	16/14/12 or better
06	18/16/14 or better
10	20/18/15 or better
25	22/19/16 or better

Dimensions DRT Series

Dimensions in mm

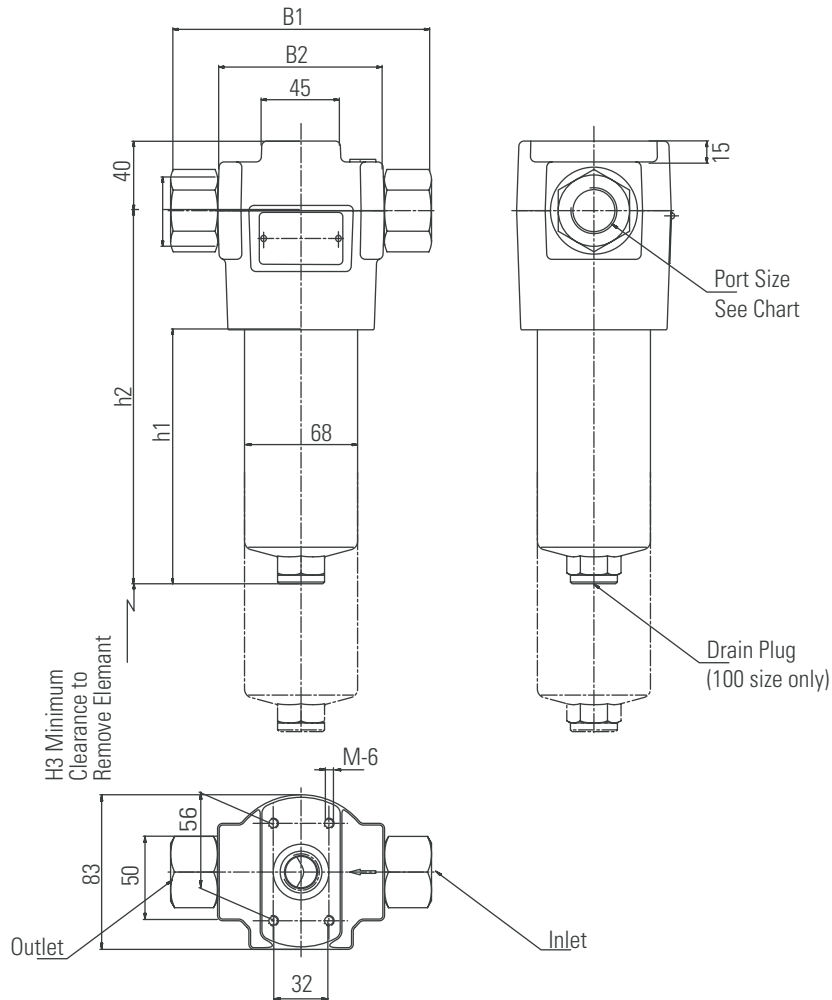

Items not in bold are non-standard and may have a longer lead time

Pressure Filters

Flows to 100 L/min (25 USgpm)
Pressures to 100 bar (1450 PSI)

DMP DIN Series Filters

Housing and Element Flow Data

DMP 040, 063, 100 Series Housing Data

TYPE	PORT SIZE	B1	B2	H1	H2	H3
DMP 040	G 1/2	–	92	91	146	75
DMP 063	G 3/4	–	92	152	207	75
DMP 100	G 1	160	–	246	301	85

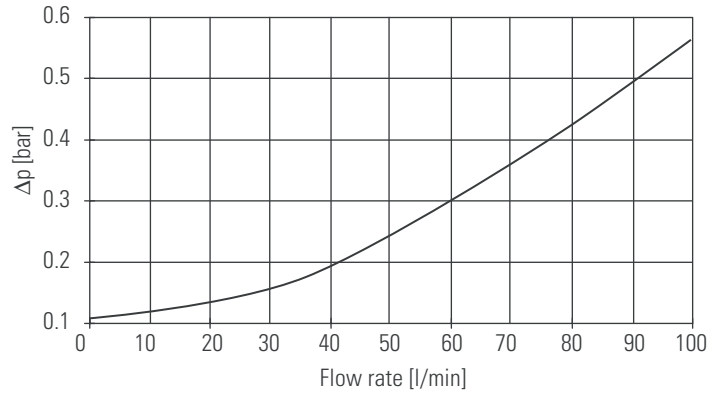

DMP Series Element Flow Data

DLR Length 160

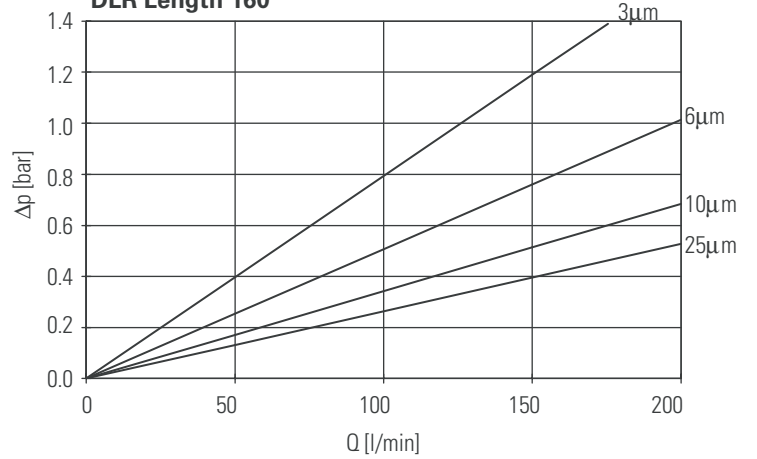

DLR Length 250

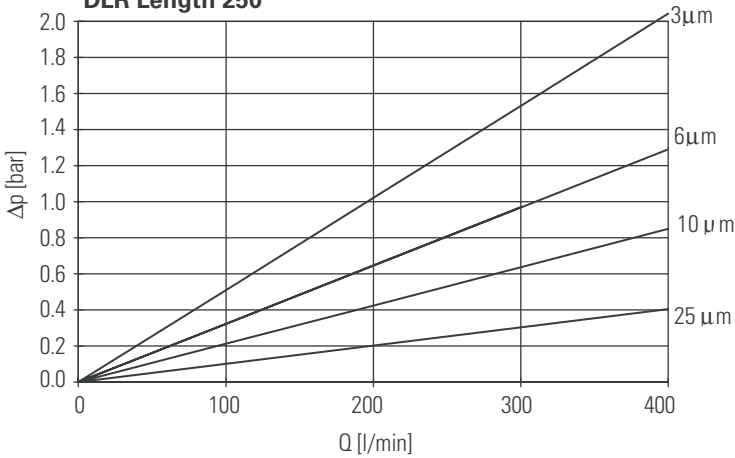

DLR Length 400

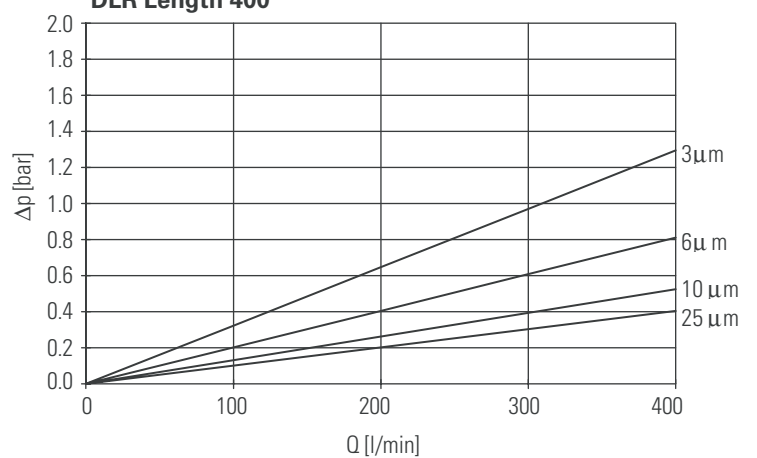

Items not in bold are non-standard and may have a longer lead time

Pressure Filters

DHP DIN Series Filters

Flows to 400 L/min (106 USgpm)
Pressures to 400 bar (5801 PSI)



Features and Benefits

- Designed to Comply with DIN 24550 specifications
- Fatigue rated:
063, 100, and 250 size: 400 bar
400 size: 210 bar
- Visual, electrical, and electrical indicators with light options for system design flexibility
- High efficiency six layer media elements
- Bypass and non-bypass options available

DESIGN SPECIFICATIONS

Rated flow:	063	63L/min (16.6USgpm)
	100	100L/min (26.4USgpm)
	250	250L/min (66.0USgpm)
	400	400L/min (105.7USgpm)
Housing & Element Compatibility:	Compatible with most petroleum oil, water glycol, and oil in-water fluids. Optional seals available for phosphate esters.	
Temp range:	-10°C to + 100°C (+14°F to +212°F)	
Pressure rating:	Operating	063, 100, 250
		400
		400 bar (5800PSI)
		210 bar (3045PSI)
Material:	Nodular Iron and Steel	
Dry weight:	063	6.0kg (13.2lbs.)
(Approximate with element)	100	7.5kg (16.5lbs.)
	250	13.0kg (28.6lbs.)
	400	28.0kg (61.7lbs.)

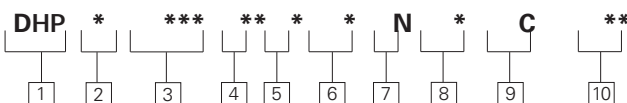

DHP Series Filter Model Code

Sample model code:
DHP1100BC4ANBC06

1 Filter Series

DHP - DIN High Pressure

2 Element Collapse Rating

1 - 435 PSI Low Collapse

4 - 2320 PSI High Collapse

3 Nominal Size

063- 63L/min (16.6USgpm)

100- 100L/min (26.4USgpm)

250- 250L/min (66.0USgpm)

400- 400L/min (105.7USgpm)

4 Port Size

TYPE	PORT SIZE	FILTER SIZE			
		63	100	250	400
BC	G 3/4	•			
BD	G 1		•		
BE	G 1-1/2			•	
BK	DN38				•

5 Valve Options

4 - Non-Bypass

6 - Bypass set at 100 PSI cracking pressure

6 Indicator Options

AN- Visual 70 PSI, No Connector

JN- No Indicator, No Connector

TB- Electrical 70 PSI, Brad Harrison Connector

TH- Electrical 70 PSI, Hirschman

8 Seal Material

B - Buna-N

V - Viton-A

Viton is a registered trademark of E.I. DuPont

9 Element Construction

C - Standard Construction

H - High Collapse Construction

10 Media Grade

03 16/14/12 or better

06 18/16/14 or better

10 20/18/15 or better

25

Items not in bold are non-standard and may have a longer lead time

Pressure Filters

DHP DIN Series

Filters

Flows to 400 L/min (106 USgpm)
Pressures to 400 bar (5801 PSI)

Dimensions DHP 063, 100 Series

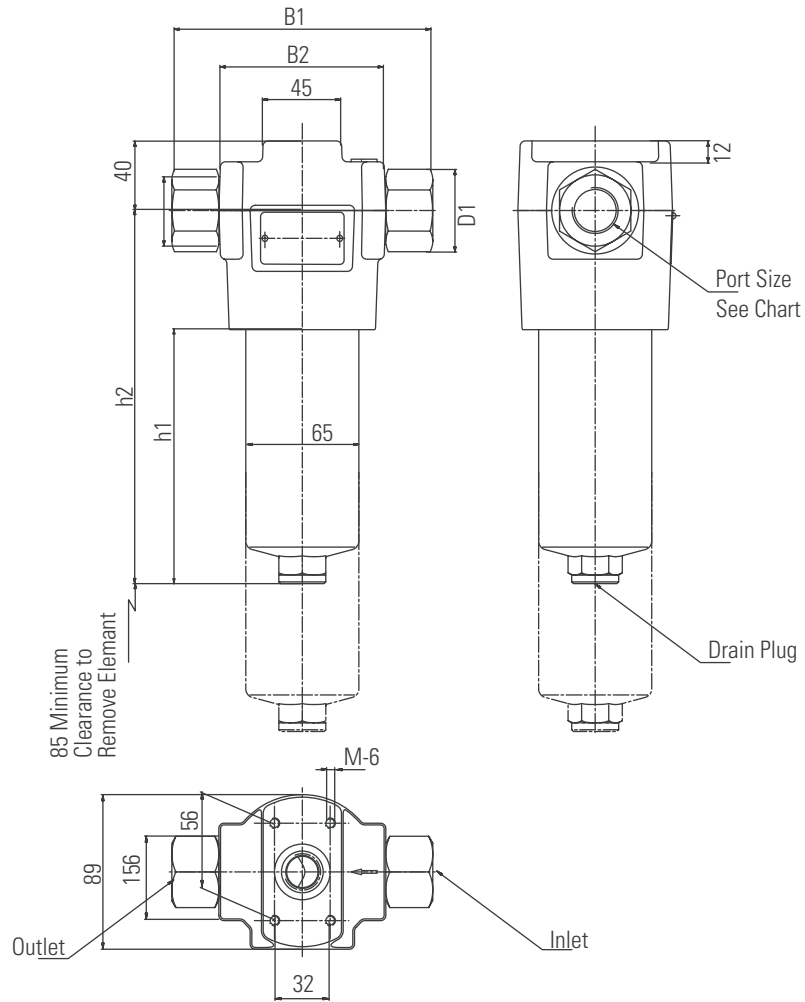

Pressure Filters

DHP DIN Series

Filters

Flows to 400 L/min (106 USgpm)
Pressures to 400 bar (5801 PSI)

Dimensions DHP 250 and 400 Series

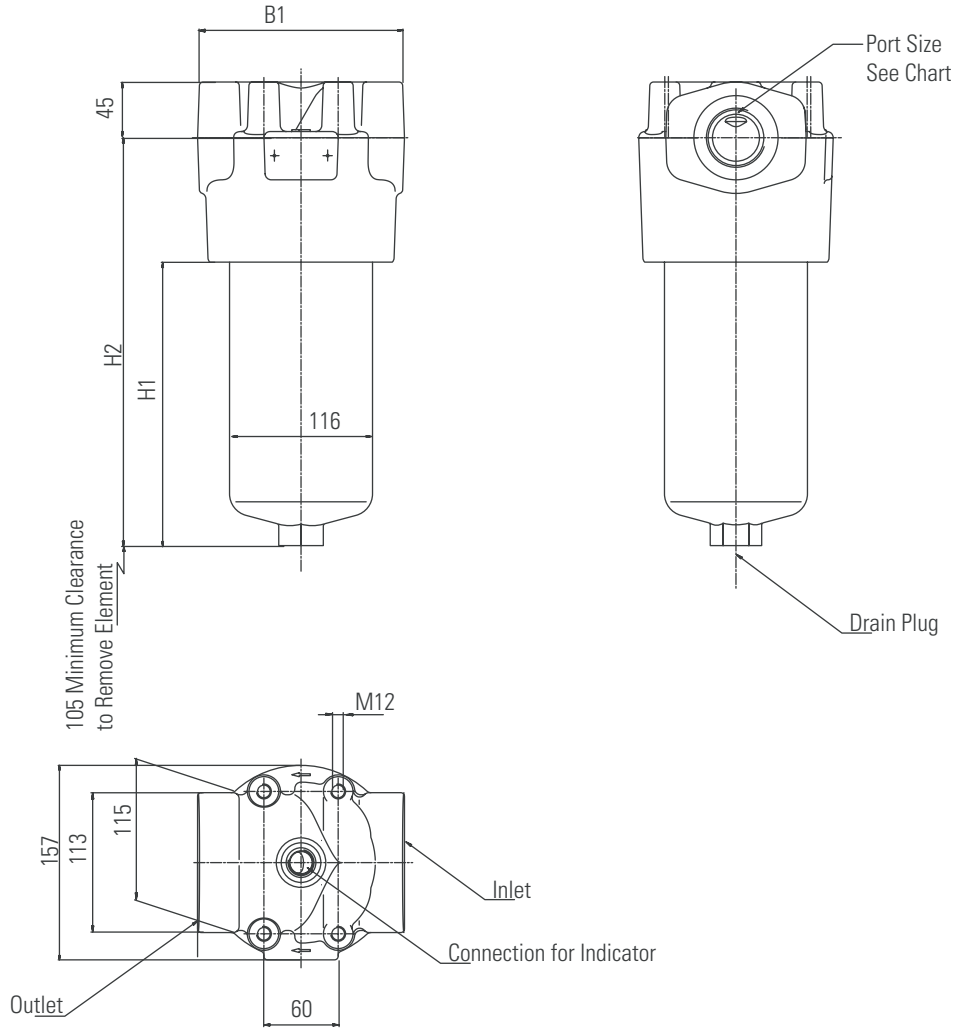

Pressure Filters

DHP DIN Series Filters

Flows to 400 L/min (106 USgpm)
Pressures to 400 bar (5801 PSI)

DHP 063, 100 Series Housing Data

Filter Housing Flow Data

Flow versus pressure drop:

32 cSt oil with specific gravity of ≤ 0.9

(See page 5 for specific gravity corrections for pressure drop.)

TYPE	PORT SIZE	B1	B2	D1	H1	H2
DHP 063	G 3/4	150	–	–	146	215
DHP 100	G 1	–	96	50	236	305

DHP 063/100

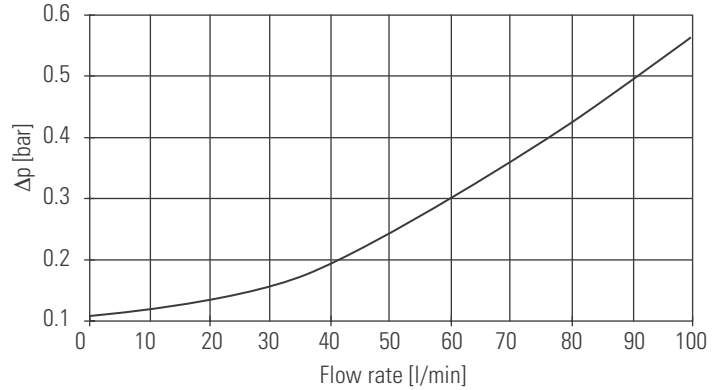

DHP 250, 400 Series Housing Data

Filter Housing Flow Data

Flow versus pressure drop:

32 cSt oil with specific gravity of ≤ 0.9

(See page 5 for specific gravity corrections for pressure drop.)

TYPE	PORT SIZE	B1	H1	H2
DFN 250	G 1 1/2	167	229	330
DFN 400	DN 38*	158	379	480

* Flange SAE 1 1/2", 3000 PSI (210 bar)

DHP 250 /400

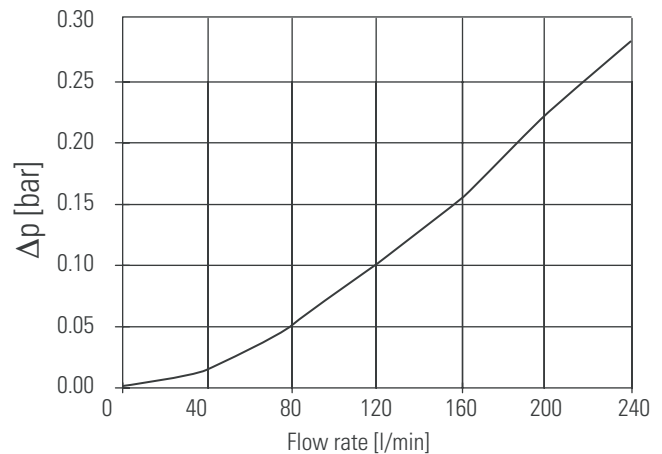

Pressure Filters

DHP DIN Series Filters

Element Model Code

(For use in DHP, DMP, and DLR Series Housings)

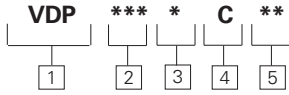

Sample model code:

VDP063BC06

1 Filter Element

VDP - DIN Standard Element

2 Nominal Size

063* - 63L/min (16.6USgpm)
100* - 100L/min (26.4USgpm)
250* - 250L/min (66.0USgpm)
400 - 400L/min (105.7USgpm)

3 Seal Material

B - Buna-N
V - Viton-A
 Viton is a registered trademark of E.I. DuPont

4 Element Construction

C - Standard Construction
H - High Collapse Construction

5 Media Grade

03 16/14/12 or better
06 18/16/14 or better
10 20/18/15 or better
25

VDP Series Element Flow Data

Flow versus pressure drop: 32 cSt oil with specific gravity of ≤ 0.9

(See page 6 for viscosity corrections for pressure drop.)

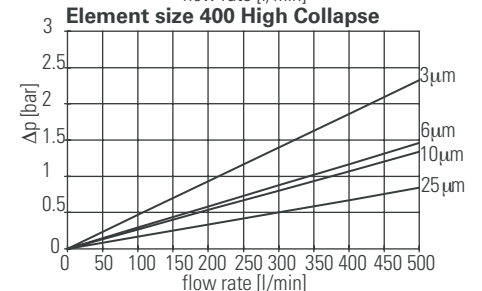
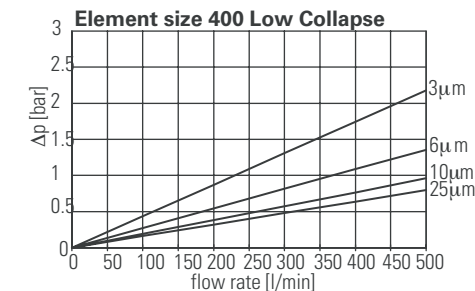
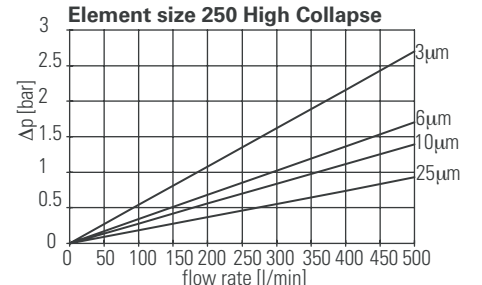
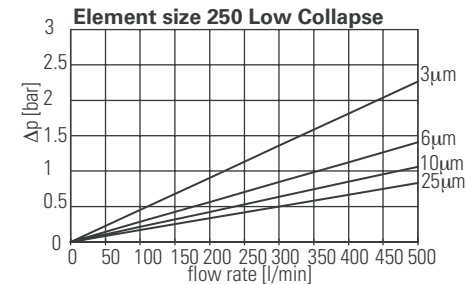
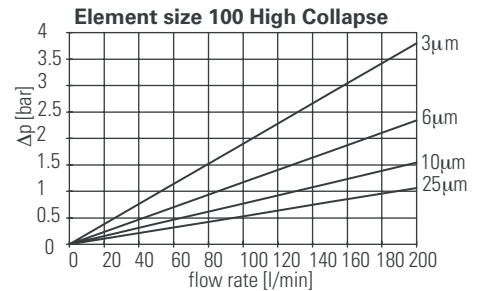
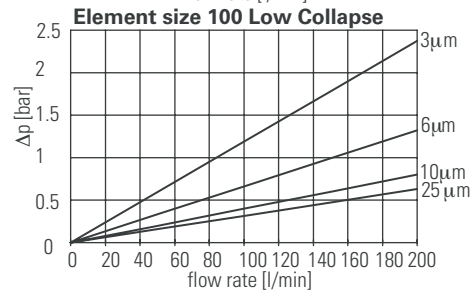
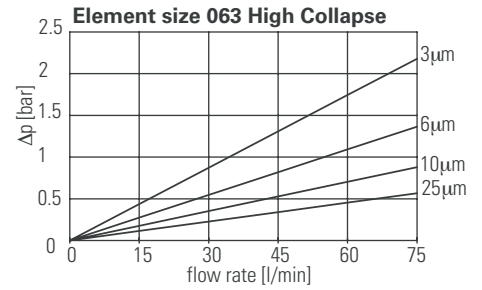
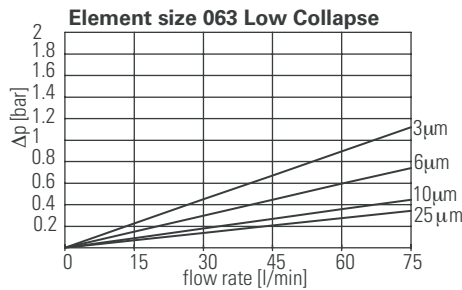

Items not in bold are non-standard and may have a longer lead time

Pressure Filters

DHP DIN Series Filters

Electrical Pressure Switch

Hirshman Connector

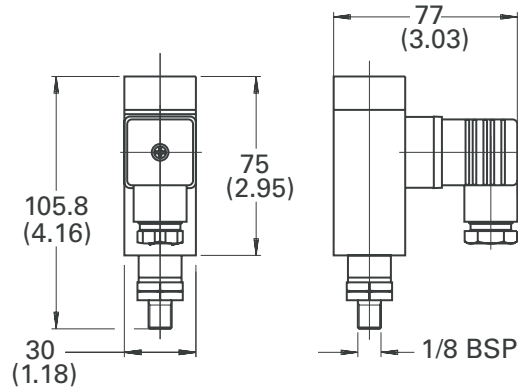

HOUSING	PART NUMBER
DRT	3039708 Electrical Switch 30 PSI Hirshman Connector

Gauge

0-10 Bar Gauge

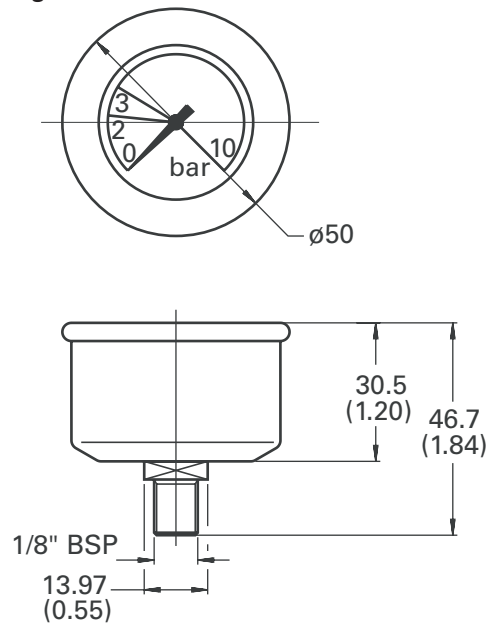

HOUSING	PART NUMBER
DRT	3039703 Gauge 0 - 10 Bar

Note: Gauges indicate pressure in both bar and PSI

Off-Line Filters

General Data

Off-line filtration systems (also referred to as a kidney loops or recirculation loops) are typically found in variable volume pump systems where system filters do not see continuous flow or where the return flow volume makes a return filter impractical. These systems typically consist of a separate pump and filter plumbed to the reservoir along with associated components to provide a continuous recirculating flow of fluid from the reservoir through the filter and back to the reservoir.

There are many advantages to incorporating an off-line filtration package. Because the system is at a low pressure and the flow is continuous with little or no flow surges, economical low pressure filter housings can be used. In addition, because temperature control is necessary to ensure that the components see the proper viscosity and that the oxidation rate of the fluid

is optimized, heat exchangers can be used within the off-line system to achieve the necessary operating parameters. The off-line system can also be used as the make-up point to add fluid to the system and help ensure that only clean fluid is introduced to the system. The off-line system can also be shut-down to change filter elements without securing the main system.

Rarely can an off-line filtration system be used as the sole contamination control solution. It is normally used to supplement the main system filters and a typical recommended size for the off-line system flow rate is approximately 20% of the total main system volume.

In addition to hydraulic systems, off-line filtration systems can be used on gearbox applications to clean the fluid where there are no other lubrication circulation systems present.

Applications

- Pulp and paper mill equipment
- Large central hydraulic power units
- Injection molding equipment
- Stamping presses
- Extrusion machines



Items not in bold are non-standard and may have a longer lead time

Off-Line Filters

EPHFF

Eaton Portable Handheld

Flows to 15 L/min (4 USgpm)
Pressures to 3.5 bar (50 PSI)



Features and Benefits

- Ideal for maintaining construction, agricultural machinery, off-highway trucks and vehicles
- Equally useful for servicing a wide variety of industrial equipment
- Incorporates a highly efficient spin-on filter element
- Relief valve housing
- Static pressure gauge clogging indicator
- Element easily replaced with snap wrench

Applications

- The portable filtration unit is a compact filter/pump device used for transferring and filtering hydraulic fluids
- Removing water from oil
- Changing oil in hydraulic systems
- Filling hydraulic systems with filtered oil.
- Off-line filtration of hydraulic systems with inadequate filtering capacity

DESIGN SPECIFICATIONS

Rated flow:	15 L/min (4 USgpm)
Fluid Compatibility:	Compatible with petroleum based fluids
Material:	Aluminum
Temp range:	Up to 80°C (180°F)
Dry weight: (Approximate)	12.5 kg (27.5 lbs)
Pressure rating:	3.5 bar (50 PSI)

TECHNICAL DATA

Fluid Compatibility:	Petroleum based oils
Nominal Flow:	4 GPM/ 15 l/min
Maximum Oil Temperature:	80°C (180°F)
Viscosity Range:	40 to 2300 SUS 5-500 mm ² /sec
Max. Operating Pressure:	50 PSI/3.5 bar
Weight:	27.5 lb/12.5 kg
Electrical Motor:	110 VAC (0.25 HP/0.18 KW)
Dimensions:	Length 3660mm (14.41") Width 3650mm (14.37") Height 3650mm (14.37")

Note: V0211B1 Elements ordered separately.
See OFRS60 Catalog pages for more information on V0211B1 series elements.

Off-Line Filters

CC OFRS 60

Clean Cart

Flows to 19 L/min (5 USgpm)
Pressures to 4 bar (65 PSI)



Features and Benefits

- Choice of 3, 5, 10, or 20 μm absolute rated filter elements, all with Beat Ratios ≥ 200 for maximum efficiency
- 10m of water removal elements with capacity of 0.45 quarts of water each
- Welded tubular steel frame for durability
- Dirt-tolerant, self-priming vane pump
- Compact design, balanced weight, and large tires for easy handling
- Spiral-reinforced, clear, 10' PVC hoses with 20" steel end wands
- 520 μm cleanable strainer before the pump

Applications

- Filter particles and/or water from new oil while filling a reservoir.
- Recirculate and filter oil during start-up, when contamination is often heaviest.
- Recirculate and filter oil off-line on systems with inadequate filtering capacity
- Empty a storage tank or reservoir
- Ideal for use in industrial plants and in other demanding applications because of their efficiency, capacity, and durability.

DESIGN SPECIFICATIONS

Rated flow:	CCOFRS60 05 CCOFRS60 10	19 L/min (5 USgpm) 38 L/min (10 USgpm)
Fluid Compatibility:	Compatible with petroleum based fluids	
Material:	Steel	
Temp range:	+10 to +54°C (+50 to +130°F)	
Dry weight: (Approximate)	52 kg (115 lbs)	
Pressure rating:	4.5 bar (65 PSI)	

TECHNICAL DATA

Fluid Compatibility:	Mineral oil, including lube and fuel oil. Note: Not allowed for use on water based fluids.	
Motor:	1750rpm, 1/2 HP (5 USgpm), 3/4 HP (10 USgpm) 110V Single Phase	
Electric Cord:	20' long	
Pump:	Direct drive vane, 5 or 10 gpm, self-priming	
Clogging Indicators:	Color coded static pressure gauge	
Strainer:	Stainless steel, 520 μm	
Hoses:	Spiral-reinforced clear PVC, standard 10' length, 20" steel wands	
Dimensions:	Height 51" Width 21.5" Length 27.5"	
Weight of Cart:	115 lbs	
Operating Range:	Fluid temperature +10 to +54°C (+50 to +130°F) Pressure to 4 bar (65 psi) Viscosity 100 - 500 SUS	

Note: V0211B1 or V0211B2 Elements ordered separately.
See OFRS60 Catalog pages for more information on V0211B1 or V0211B2 series elements.

Items not in bold are non-standard and may have a longer lead time

Off-Line Filters

OLF15V

Off-Line Filtration Package

Flows to 19 L/min (4.9 USgpm)
Pressures to 3 bar (45 PSI)



Features and Benefits

- Ultra high efficiency membrane element technology Beta₂>1000
- Compact design
- Water removal elements available
- 20 micron element available for gear box applications
- High capacity elements (200 grams)
- Single Vane pump- 5 USgpm (19 L/min) capacity @3 bar.
- Driven by AC motor

Applications

The OLF 15V is ideal for systems in which the ingress rate of contamination is relatively low. Applications well suited for the new product include:

- Plastic injection molding systems
- In-plant press systems
- Systems that contain less than 500 gallons of fluid gearbox applications and the associated fluid viscosity, 2 limit the media that can be used in the OLF 15V. The 2-micron element is limited to a viscosity of 2500 SUS. The 20-micron element can be used up to a viscosity level of 5000 SUS.
- The 20-micron element is normally more than adequate for gearbox applications.

DESIGN SPECIFICATIONS

Rated flow:	19 L/min (4.9 USgpm)
Fluid Compatibility:	Compatible with petroleum based fluids
Material:	Aluminum
Temp range:	-20 to +40°C (-4 to +104°F)
Dry weight: (Approximate)	11 kg (24.3 lbs)
Pressure rating:	3 bar (45 PSI)

TECHNICAL DATA

Operating Range	
Viscosity:	3000 SUS
Operating Pressure:	3 bar (45 psi)
Suction Pressure:	-0.4 bar (11" Hg) max
Inlet Pressure	10 bar (145 psi) min
Fluid Temperature:	0 to +80°C (+32 to +175°F)
Ambient Temperature:	-20 to +40°C (-4 to +104°F)
Seals:	Buna-N
Maximum Flow Rate:	18.5 L/min (4.9 USgpm)
Elements	
Dirt Holding Capacity:	200g ISO MTD, or approximately 0.45lbs
Water Retention:	(ΔP = 2.5 bar [36 psi]): Approximately 0.5 quarts (0.5 liters)
Beta Ratio:	β ₂ > 1000 (absolute value)
Maximum ΔP:	3 bar (45 psi)
Dimensions:	Length 538mm (21.2") Width 168mm (6.61") Height 109mm (7.48")

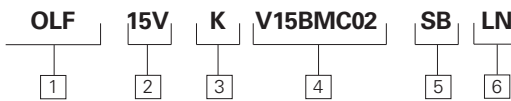

OLF15V Off-Line Filtration Package Model Code

1 OLF- Filtration Unit

2 15V - 15 L/min Vane Pump

3 Motor Voltage

K - 115 Volt AC, 1 Phase, 60Hz
M - 220 Volt AC, 1 Phase, 50Hz
N - 220/440 Volt AC, 3 Phase, 50 or 60Hz

4 Filter Element

V15BMC02 - 2 Micron filter element
V15BMW02 - 2 Micron filter with water removal element
V15BMC20 - 20 Micron filter element
V15BMW20 - 20 Micron filter with water removal element

5 Valve Options

SB - 1-5/16-12 (SAE-16)
BB - G-1 BSPP thread

6 Indicator Options

JN - No indicator (plug), No Connector
LN - Visual 30 PSID, No Connector
RB - Electrical 30 PSID, Brad Harrison
RH - Electrical 30 PSID, Hirshman
RJ - Electrical 30 PSID, Hirshman with 24 Volt light
RK - Electrical 30 PSID, Hirshman with 115 Volt light
RL - Electrical 30 PSID, Hirshman with 230 Volt light

Accessories

Fluid Sampling

Features and Benefits

Remove metal dustcover on discharge port. Discharge approximately 200 ml of oil to flush valve by turning knurled knob 1/4 turn to the right. Dispose of this sample in the appropriate manner. Locate clean oil sample bottle under discharge port. (Sample bottles are usually supplied by the oil analysis lab.) Turn knurled knob 1/4 turn to the right until bottle is filled to the desired level. The knob can be backed off to throttle the rate of flow. When bottle is filled let go of the knurled knob, the valve will close automatically. Replace metal dustcover wrench tight.

Applications

Engine oil, lubricating oil, transmission fluid and hydraulic fluids in mobile construction equipment, military vehicles, trucks and stationary equipment.

For best results, Eaton FD15 Oil Sampling Valves should be installed in dynamic fluid lines in low pressure and return lines. If only one sampling point can be chosen, it should be in the return line, upstream of any return line filter. This will insure a representative sample of all components in the fluid system for their present condition.



0-50 psi

PART NUMBER	INLET PORTS
FD15-1026-04	1/4" NPTF
FD15-1025-04	7/16-20 Male ORB

As required in MIL-V-81940/2-1 this valve's flow rate is between 100 and 1500 milliliters per minute at pressures from 0-50 psi. (MIL-V-81940/2-1 applies only to pressures from 50-300 psi.)



50-300 psi

PART NUMBER	INLET PORTS
FD15-1000-02	1/8" NPTF
FD15-1000-04*	1/4" NPTF
FD15-1002-04	7/16-20 Male ORB

*The 1/4" NPTF version is qualified to MIL-V-81940/2-1 and its performance is representative of the other inlet port configurations listed above. QPL-81940-9 6-5-89

DESIGN SPECIFICATIONS

Construction:	Corrosion resistant plated steel with brass internal components and Buna-N seal
Operating Temp range:	-53°C to +135°C (-65°F to +275°F)
Minimum Burst Pressure:	1200psi
Minimum Particle Restriction:	500 microns
Maximum Torque to Operate:	10 in. lbs.

Note: This valve is not intended for aerospace applications

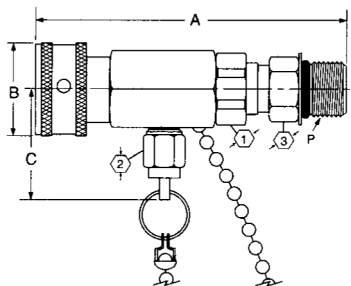

INDICATOR OPTIONS (3000 PSI - USE WITH FILTER MODELS HV6R, HV3R)

Coupling Size	Thread Size (P)	Dimension Data			①	②	③	Part No. Buna-N
		A	B	C				
—	1/8-27	2.42	1.00	1.30	.69	.38	—	FD15-1000-02
—	1/4-18	2.56	1.00	1.30	.59	.38	—	FD15-1000-04
—	7/16-20	2.79	1.00	1.30	.69	.38	.56	FD12-1002-04
—	1/4-18	2.56	1.00	1.30	.69	.38	—	FD15-1026-04
—	7/16-20	2.79	1.00	1.30	.69	.38	.56	FD12-1025-04

Items not in bold are non-standard and may have a longer lead time

Accessories

Differential Indicators

DESIGN SPECIFICATIONS

Material:	PV/PE Series PHV/PHE Series	Aluminum Stainless Steel
Fluid compatibility:	Compatible with most petroleum oil, oil-in-water and water-in-oil fluids. Optional seals available for phosphate esters	
Installation Torque:	PV/PE Series PHV/PHE Series	33 Nm (24 lbs-ft) 100 Nm (74 lbs-ft)
Temp range:	-26°C to +120°C (-15°F to +250°F)	
Switch Rating (all models):	3A@24VDC 5A@250VAC	
Dry weight: (Approximate)	PV PHV PE PHE	55g (0.1lbs) 110g (0.2lbs) 150g (0.3lbs) 250g (0.6lbs)
Pressure rating:	PV/PE Series PHV/PHE Series	210 bar (3000PSI) 420 bar (6000PSI)

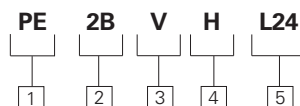

Indicator Model Code

1 Indicator type and pressure rating

PV - visual 210 bar (3000PSI)
PE - electrical 210 bar
PHV - visual 420 bar (6000PSI)
PVE - electrical 420 bar (6000PSI)

2 Pressure setting

1B - 1 bar (15PSID)
2B - 2 bar (30PSID)
5B - 5 bar (75PSID)
8B - 8 bar (115PSID)

3 Seal material

V - Viton-A

4 Connector

B - Brad Harrison 5 Pin
H - Hirschman
N - None (use with PV indicators)

5 Light option

L24 - 24 Volt Lamp
L115 -115 Volt Lamp
L230 -230 Volt Lamp

INDICATOR OPTIONS (3000 PSI - USE WITH FILTER MODELS HV6R, HV3R)

Description	Model	Filter Assembly Code Letters
POPOP VISUAL 15PSI	PV 1B VN	KN
POPOP VISUAL 30PSI	PV 2B VN	LN
POPOP VISUAL 70 PSI	PV 5B VN	AN
BRAD HARRISON 5 PIN ELECTRICAL 15 PSI	PE 1B V B	QB
BRAD HARRISON 5 PIN ELECTRICAL 30 PSI	PE 2B V B	RB
BRAD HARRISON 5 PIN ELECTRICAL 70 PSI	PE 5B V B	UB
HIRSCHMAN ELECTRICAL 15 PSI	PE 1B V H	QH
HIRSCHMAN ELECTRICAL 30 PSI	PE 2B V H	RH
HIRSCHMAN ELECTRICAL 70 PSI	PE 5B V H	UH
HIRSCHMAN VISUAL ELECTRICAL 15 PSI - L24	PE 1B V H L24	QJ
HIRSCHMAN VISUAL ELECTRICAL 30 PSI - L24	PE 2B V H L24	RJ
HIRSCHMAN VISUAL ELECTRICAL 70 PSI - L24	PE 5B V H L24	UJ
HIRSCHMAN VISUAL ELECTRICAL 15 PSI - L115	PE 1B V H L115	QK
HIRSCHMAN VISUAL ELECTRICAL 30 PSI - L115	PE 2B V H L115	RK
HIRSCHMAN VISUAL ELECTRICAL 70 PSI - L115	PE 5B V H L115	UK
HIRSCHMAN VISUAL ELECTRICAL 15 PSI - L230	PE 1B V H L230	QL
HIRSCHMAN VISUAL ELECTRICAL 30 PSI - L230	PE 2B V H L230	RL
HIRSCHMAN VISUAL ELECTRICAL 70 PSI - L230	PE 5B V H L230	UL

Accessories

Differential Indicators

INDICATOR OPTIONS (6000 PSI - USE WITH FILTER MODELS HF2P, HF3P, HF3PS, HF4P)

Description	Model	Filter Assembly Code Letters
POPOP VISUAL 30PSI	PHV 2B VN	LN
POPOP VISUAL 70 PSI	PHV 5B VN	AN
POPOP VISUAL 115 PSI	PHV 8B VN	ON
BRAD HARRISON 5 PIN ELECTRICAL 30 PSI	PHE 2B V B	RB
BRAD HARRISON 5 PIN ELECTRICAL 70 PSI	PHE 5B V B	UB
BRAD HARRISON 5 PIN ELECTRICAL 115 PSI	PHE 8B V B	TB
HIRSCHMAN ELECTRICAL 30 PSI	PHE 2B V H	RH
HIRSCHMAN ELECTRICAL 70 PSI	PHE 5B V H	UH
HIRSCHMAN ELECTRICAL 115 PSI	PHE 8B V H	TH
HIRSCHMAN VISUAL ELECTRICAL 30 PSI - L24	PHE 2B V H L24	RJ
HIRSCHMAN VISUAL ELECTRICAL 70 PSI - L24	PHE 5B V H L24	UJ
HIRSCHMAN VISUAL ELECTRICAL 115 PSI - L24	PHE 8B V H L24	TJ
HIRSCHMAN VISUAL ELECTRICAL 30 PSI - L115	PHE 2B V H L115	RK
HIRSCHMAN VISUAL ELECTRICAL 70 PSI - L115	PHE 5B V H L115	UK
HIRSCHMAN VISUAL ELECTRICAL 115 PSI - L115	PHE 8B V H L115	TK
HIRSCHMAN VISUAL ELECTRICAL 30 PSI - L230	PHE 2B V H L230	RL
HIRSCHMAN VISUAL ELECTRICAL 70 PSI - L230	PHE 5B V H L230	UL
HIRSCHMAN VISUAL ELECTRICAL 115 PSI - L230	PHE 8B V H L230	TL

Differential Indicator Dimensional Schematics

PE * B V B
PHE * B V B

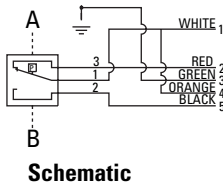
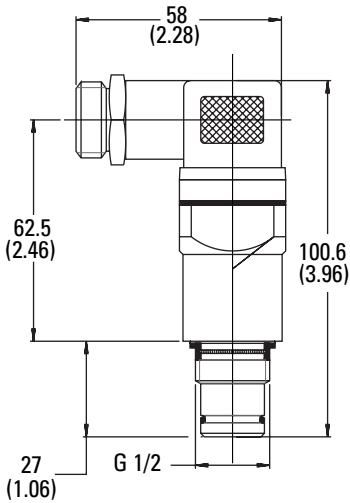

PV * B VN

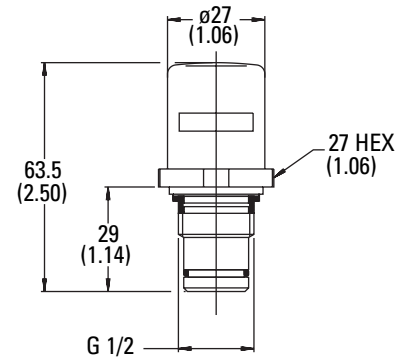

PE * B V H
PHE * B V H

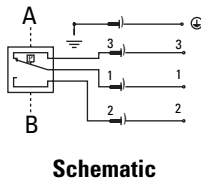
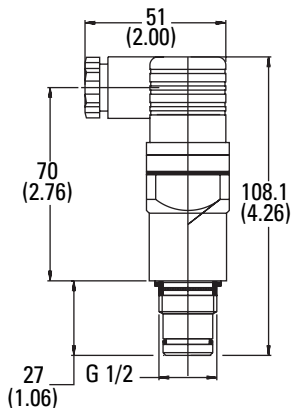

PE * B V H L **
PHE * B V H L **

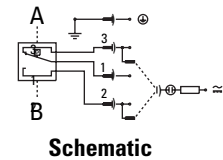
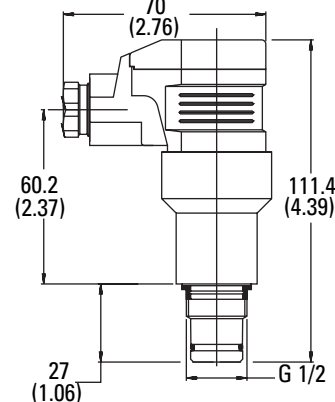

Items not in bold are non-standard and may have a longer lead time

Accessories

Indicator Switch

Schematic Wiring Diagram

Note:

The female connector is to be furnished by the customer.

Note:

When fitting indicator, torque to 41-47 Nm.

ELECTRICAL

Switch: SPDT

Rating: 7 amps, resistive
4 amps, inductive
2 amps, lamp load
@28 VDC, 115 VAC 60 Hz
& 220 VAC 50 Hz or 60 Hz

Hirschmann (DIN 43650 Type AM) Receptacle

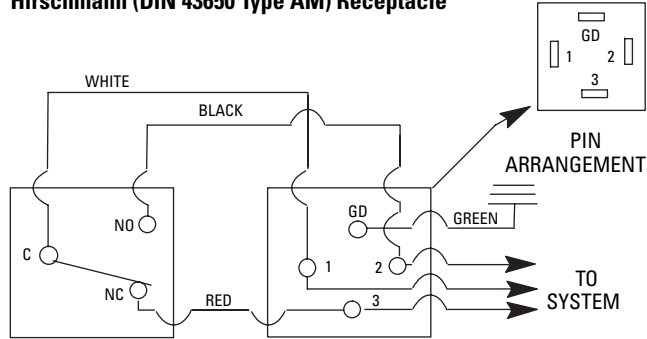

Brad Harrison (41512) Receptacle

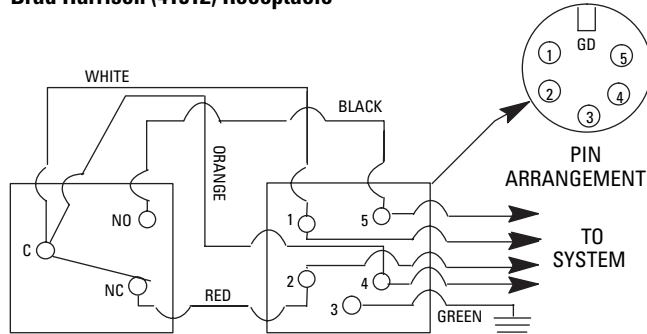

Electrical Pressure Switch

HOUSING	PART NUMBER
HF4T	3039705 Electrical Switch 15 PSI Brad Harrison Connector 3039707 Electrical Switch 15 PSI Hirshman Connector
HF4T	3039706 Electrical Switch 30 PSI Brad Harrison Connector 3039708 Electrical Switch 30 PSI Hirshman Connector

Hirshman Connector

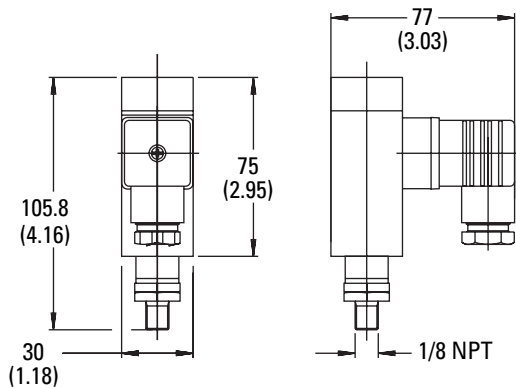

Brad Harrison Connector

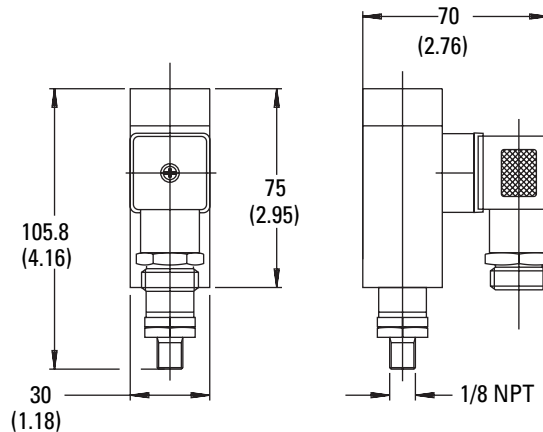

Items not in bold are non-standard and may have a longer lead time

Accessories

Gauge

HOUSING	PART NUMBER
HF4T	3039703 Gauge 0-160 PSI (use with 43 PSI Bypass Valve)
	3039704 Gauge 0-60 PSI (use with 25 PSI Bypass Valve)

Note:

Gauges indicate pressure in both bar and PSI

0-4 Bar (0-60 PSI) Gauge

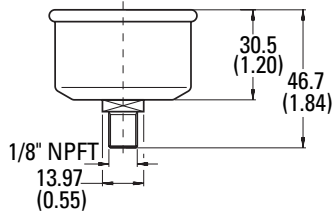
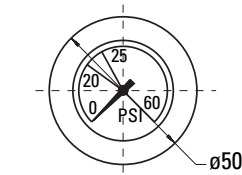

0-10 Bar (0-160 PSI) Gauge

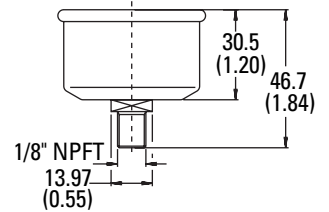
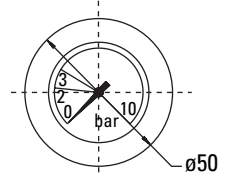

Mounting Bracket

HV6R Housing

mm (inch)

Order part number 3039702

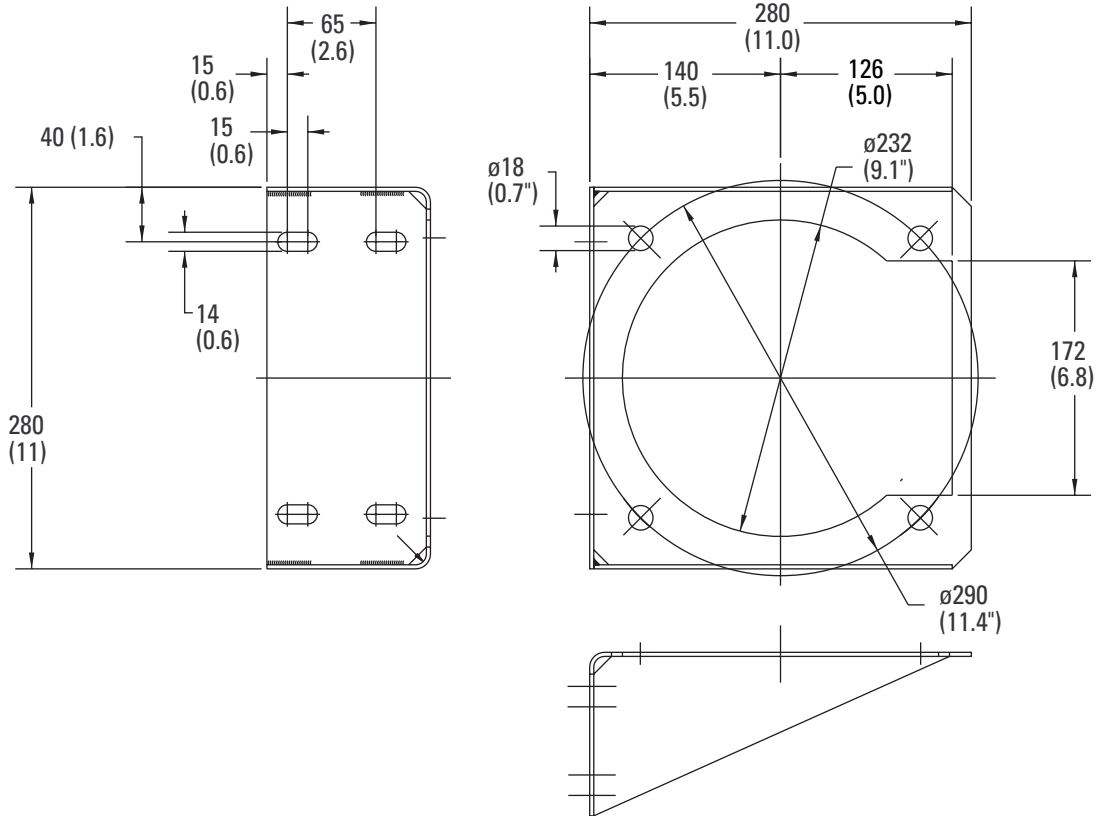

Weld Flange

For use with HF4T P-232964-01

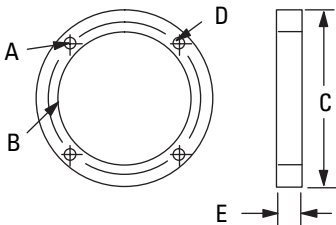

DIMENSIONS

Housing	A	B	C	D	E
HL 15, HL 16	$\frac{7}{16}$ - 20 UNF	127,0	181,0	$\frac{7}{16}$ - 20 UNF x 0.75	12,7
P-232964-01	thru (4) on 6.25 dia. BC equally spaced	(5.00)	(7.12)	Recommended bolts	(0.50)

Items not in bold are non-standard and may have a longer lead time

Eaton
14615 Lone Oak Road
Eden Prairie, MN 55344
USA
Tel: 952 937-9800
Fax: 952 974-7722
www.hydraulics.eaton.com

Eaton
20 Rosamond Road
Footscray
Victoria 3011
Australia
Tel: (61) 3 9319 8222
Fax: (61) 3 9318 5714

Eaton
Dr.-Reckeweg-Str. 1
D-76532 Baden-Baden
Germany
Tel: (49) 7221 682-0
Fax: (49) 7221 682-788



© 2005 Eaton Corporation
All Rights Reserved
Printed in USA
Document No. E-FIFI-MC002-E
Supersedes V-FIFI-MC001-E
August 2005